

Conveyor Systems 38 and 60 mm

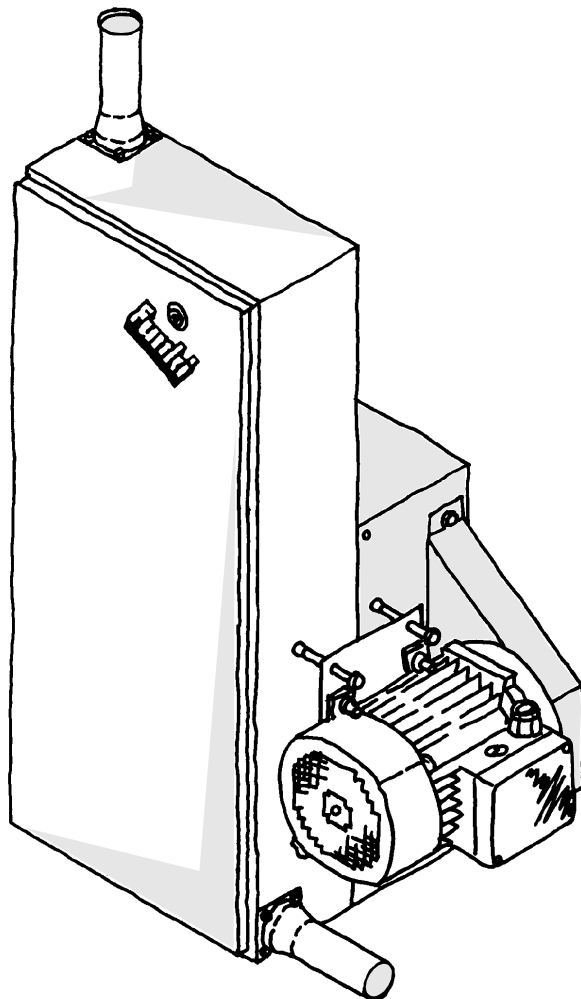

- Conveys and distributes all prevalent feed components, pellets as well as grinded components:
 - no feed separation
 - minimum crushing of pellets
- Conveyor capacity up to 1200 kg per hour.
- Conveyor length up to 350 m and 8 corners.
- Custom-made, double-winded "Aircraft" steel wire with plastic discs - special casting technique used.
Or newly-developed steel chain with plastic discs combining high strength with the light and self-emptying construction of the conventional wire.
- Long-lasting chain.
- Horizontal or vertical wall-mounting.

The Funki feeding machines are a result of more than 35 years of experience and development.

The feeding machines are available in several models with conveyor capacities from 200 up to 1200 kg per hour.

The feeding machine is equipped with 3 safety systems to prevent cable break-downs and other serious stop-downs.

Wire as well as PowerLine chain can be supplied for the feed machines, depending on the job.

With this system you will obtain large capacity and reliable operation.

Funki Conveyor Systems - fits all types of housing systems

Technical Specifications

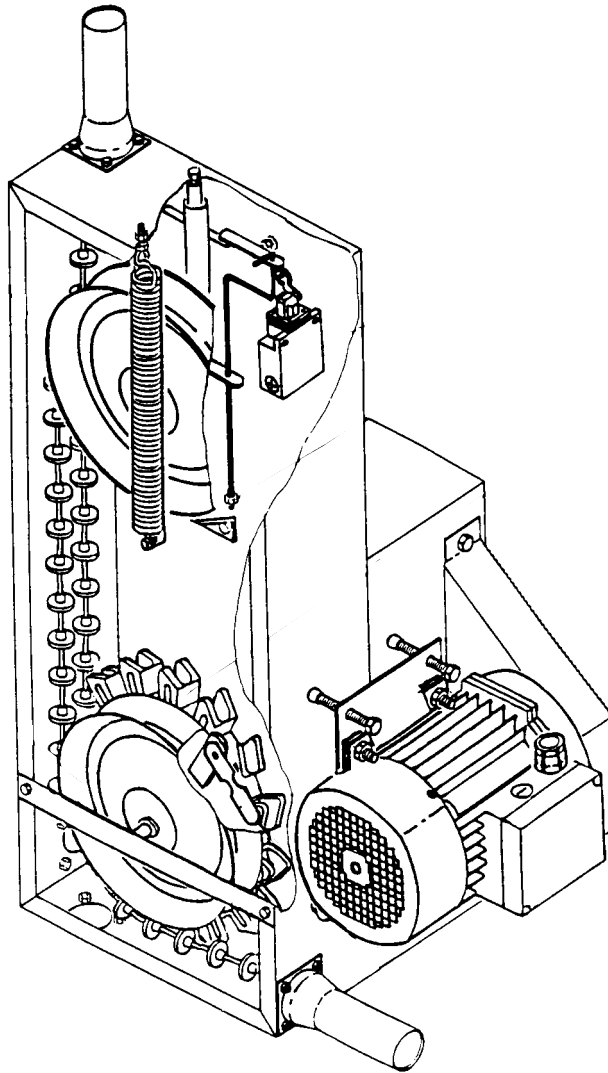

Drive unit	38 mm	60 mm
Conveyor pipe diameter	38 mm	60 mm
Conveyor speed	12/24 m/min.	12/19 m/min.
Size of motor	0.55/0.75 kW	see Data Sheet 2-005
Conveyor capacity, max.	300/600 kg/hour	700/1000 kg/hour
Max. length at 8 corners, *	350 m	350 m
Reduction of length per corner, *	15 m	20 m
Max. number of corners - wire	22	21
Max. number of corners - chain	20	-
Separate reception unit	Yes	Yes

* By use of wire or PowerLine chain.