

MOUNTING INSTRUCTION

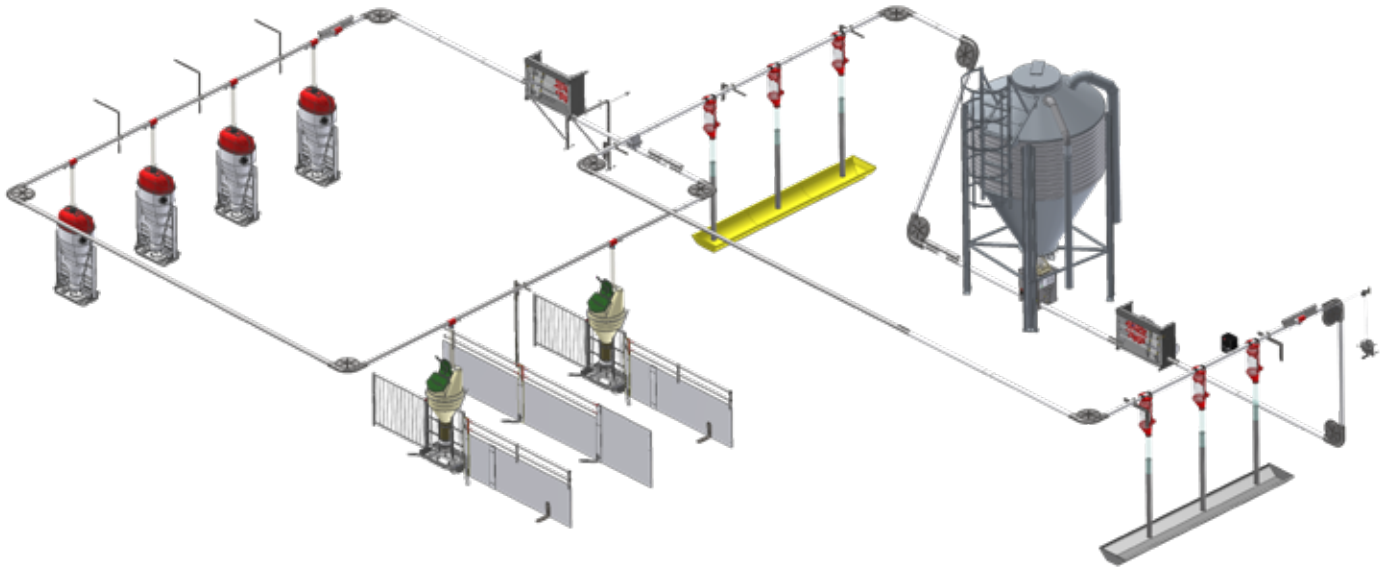

DRY FEEDING SYSTEMS OVERVIEW AND RULES



ACO FUNKI A/S
Kirkevænget 5
DK-7400 Herning

Tel. +45 9711 9600
Fax +45 9711 9677
www.acofunki.com

INDEX

Overview of documents concerning dry feeding systems	2
Preparation and safety	4
Maintenance	5
Rules for mounting	6
Mounting	10

M-1051	Overview of dry feeding
	FEEDERS
M-1008	T-piece and down pipes
M-1015	FUNKIMAT
M-1024	Double FUNKIMAT
M-1028	TUBE-O-MAT TUBE
M-1029	TUBE-O-MAT JUMBO TUBE
M-1032	AD-LIB FEEDER
M-1033	BOX FEEDER - Weaners
M-1034	BOX FEEDER - Finishers
M-1036	BABYFEEDER
M-1037	BABYFEEDER quick guide
M-1045	TUBE-O-MAT NX V+
M-1046	TUBE-O-MAT NX CLASSIC
M-1047	TURBOMAX FEEDER
M-74800	TUBE-O-MAT_VI+_Dosing kit
M-76012	TUBE-O-MAT_VI+
M-76017	TUBE-O-MAT_VI+_JUMBO
M-76020	TUBE-O-MAT_LTD_CLASSIC
M-76021	TUBE-O-MAT_LTD_CLASSIC_JUMBO
M-76024	TUBE-O-MAT_CLASSIC
M-76025	TUBE-O-MAT_CLASSIC_JUMBO
M-76026	TUBE-O-MAT_LTD_VI+
M-76027	TUBE-O-MAT_LTD_VI+_JUMBO
	VOLUME DOSERS
M-1009	VD2
M-1010	VD22
M-1011	VD6
M-1018	VD100
M-1019	VD5
M-1030	Opening system for VD2 og VD6
M-1031	LINAK Tech system

	SYSTEM OG TRANSPORT
M-1038	MULTICONTROLLER / Stop sensor
M-1039	S3 Stop sensor print
M-1040	Reception unit
E-1042	MULTICONTROLLER (electrical diagram)
M-1044	SINGLE DRY
M-1049	MAXI DRIVE UNIT
M-1050	User guide FUNKINET AUTOFEED_DRY
M-1052	Support system for feeding
M-1053	Funki MULTI DRY - INDIVIDUAL
M-1054	Funki MULTI DRY - SECTION
M-1055	Funki MULTI DRY - CURVE SECTION
M-1056	Pipe drain
M-1057	Flex auger reception unit
	MILK AND STRAW
M-1041 + U-1041	BABY CARE Milk system + User manual
M-1043	MULTI STRAW
	SILO AND FLEX AUGERS
M-4001	Steel silo
M-4003	Flex auger

OVERVIEW OF DOCUMENTS CONCERNING DRY FEEDING SYSTEMS

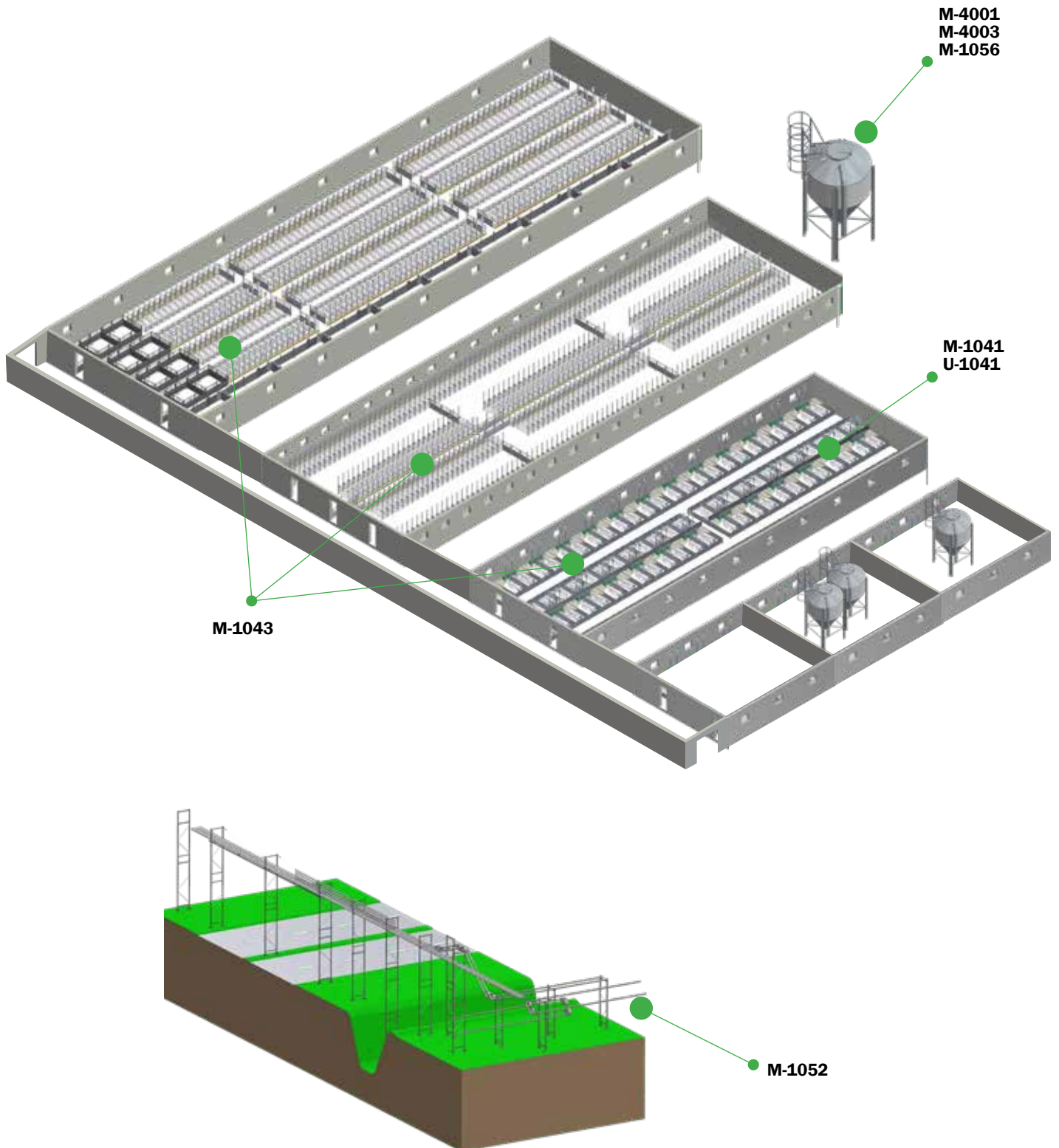

PREPARATION AND SAFETY

Before mounting

- Plan the transport line through the barn, as well as the location of the individual elements
- We recommend the use of as few corners as possible
- Determine the location of the drive unit - consider whether it is to be mounted to a wall or the floor

Mounting height

We recommend that the feed pipe is mounted at the height of **2,2 - 2,4 m**. Ensure that the feed outlets are placed where personnel can reach for inspection.

Be aware of the following:

- Ceiling height
- Windows, doors, gates etc. should be able to open freely
- Steel rafters and other things that protrude from the wall or hang down from the ceiling
- Ventilation systems, posts, other piping etc. which the transport line must be able to pass
- Consider where it is possible to fasten and support the feed pipes

Safety



**DURING SERVICE AND MAINTENANCE THE POWER MUST BE SHUT OFF!
LOCK THE MAIN SWITCH ON THE CONTROL CABINET.**

Always cut off the power and lock the main switch before disassembling the system, as well as before removing screens, lids or covers.

Never insert objects or body parts (eg hands) into feed outlets or other openings in order to clean for feed residue or the like, without first cutting off the power and locking the system.

Installation and repair of electrical installations may only be carried out by an authorized electrician.



WEAR A DUST MASK WHEN USING A BRUSH FOR CLEANING

MAINTENANCE

SERVICE- AND MAINTENANCE INTERVALS			
Task / job	Immediately after start-up	For every 500 operating hrs.	For every 1000 operating hrs.
Wire			
Check wire for wear and damaged threads		X	
Check plastic plates for wear		X	
Check and tighten wire joint	X	X	
Check wire tension. Shorten, if necessary	X	X	
Master Chain chain			
Check chain for twisting*	X		
Check wire for wear			X
Check plastic plates for wear		X	
Check joint link for wear			X
Check chain tension. Shorten, if necessary**	X	X	
PowerLine chain			
Check chain for twisting*	X		
Check wire for wear			X
Check plastic plates for wear		X	
Check joint link for wear			X
Check chain tension. Shorten, if necessary**	X	X	
Feed transport corners			
Check for jarring sounds (scraping or wheezing sounds)	X	X	
Open and clean feed bends using a brush (wear a dust mask)			X
Check inner wheel bearings for looseness			X
Check inner wheel for wear			X

* After 5 minutes of operation, control the system for “twists” on the chain. This can be checked in the drive unit, as any twists will be located just before the drive unit. If any twists are found, the chain must be disassembled, straightened and reassembled.

** After some time of operation, the PowerLine and Master Chain will stretch, causing the distance between the drive wheel and the tension wheel to increase. Shorten the chain before the tension wheel activates the microswitch. This is done by removing some of the links from the chain and assembling the chain with a joint. See the user manual for the drive unit.

The feed wire or feed chain will normally stretch after a while. Therefore, pay special attention to the wire, and check the items marked in the “After start-up” column regularly (in the first 2-3 weeks).

RULES FOR MOUNTING

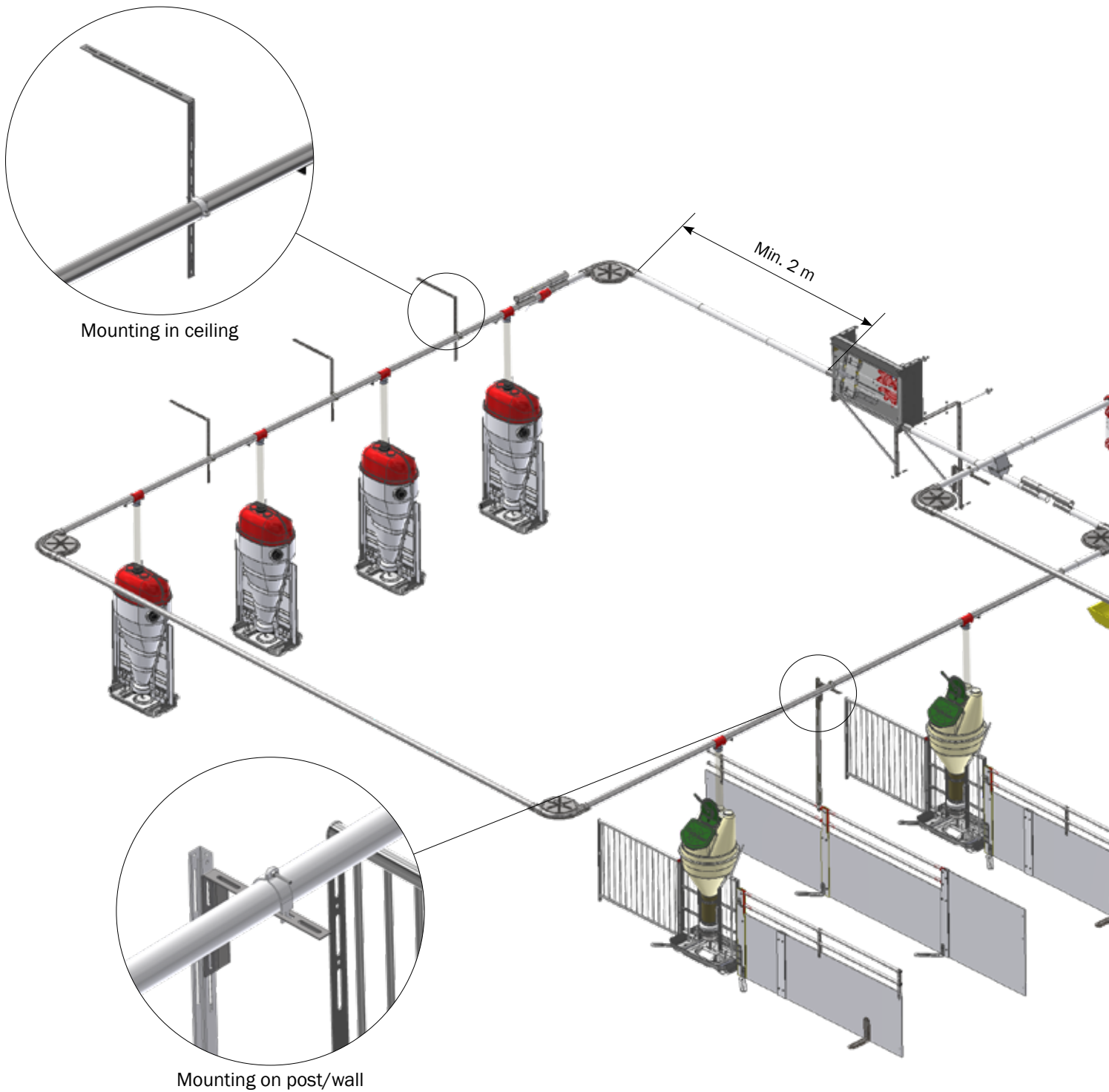

Rules

- We recommend that the drive unit is placed on the return side
- Mount the drive unit min. 2 m from a corner
- Place mounting brackets with a distance of max. 3 m
- Place mounting brackets max. 0,5 m from a corner
- Place stop sensor min. 2 m from a corner

RULES FOR MOUNTING

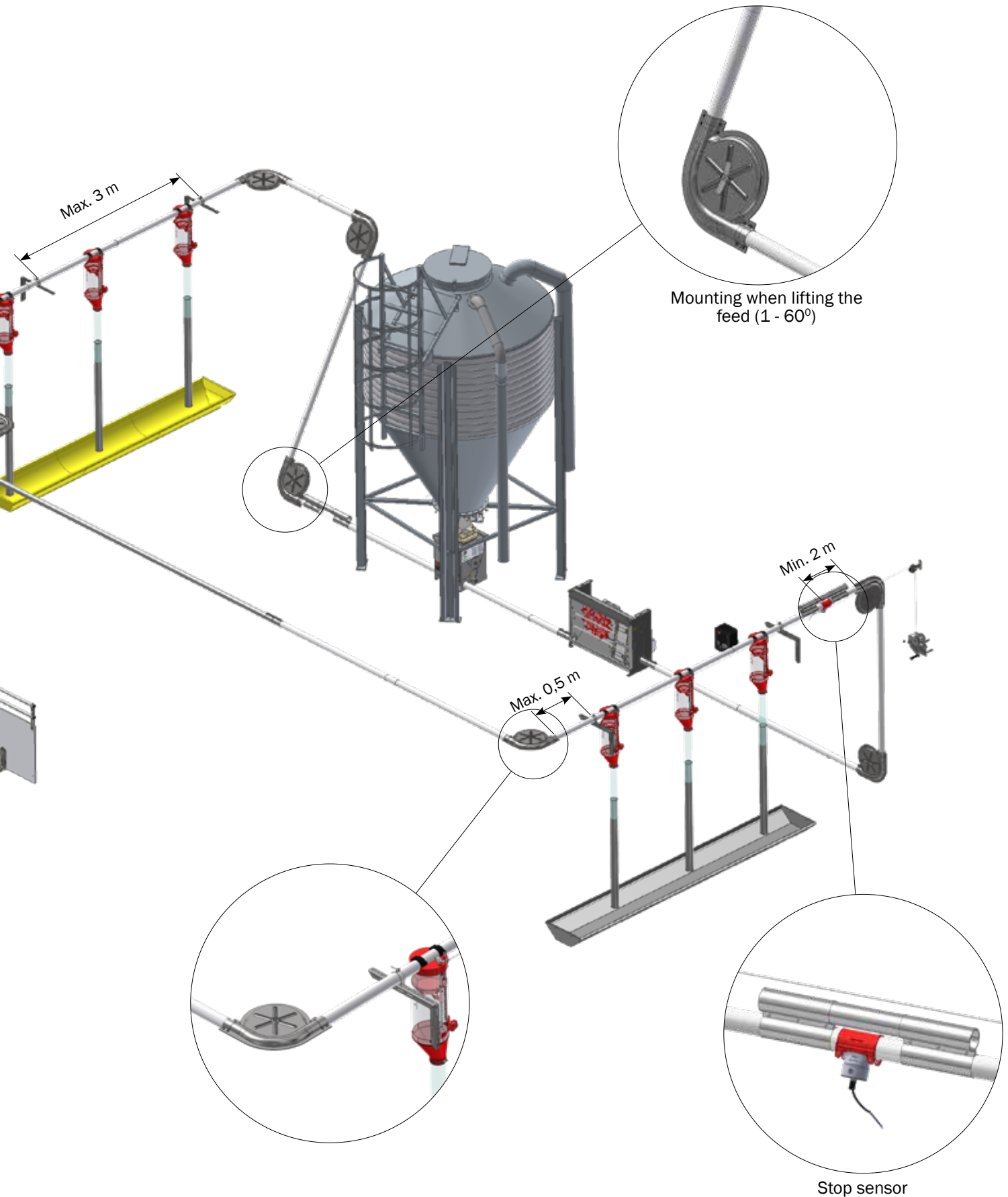

RULES FOR MOUNTING

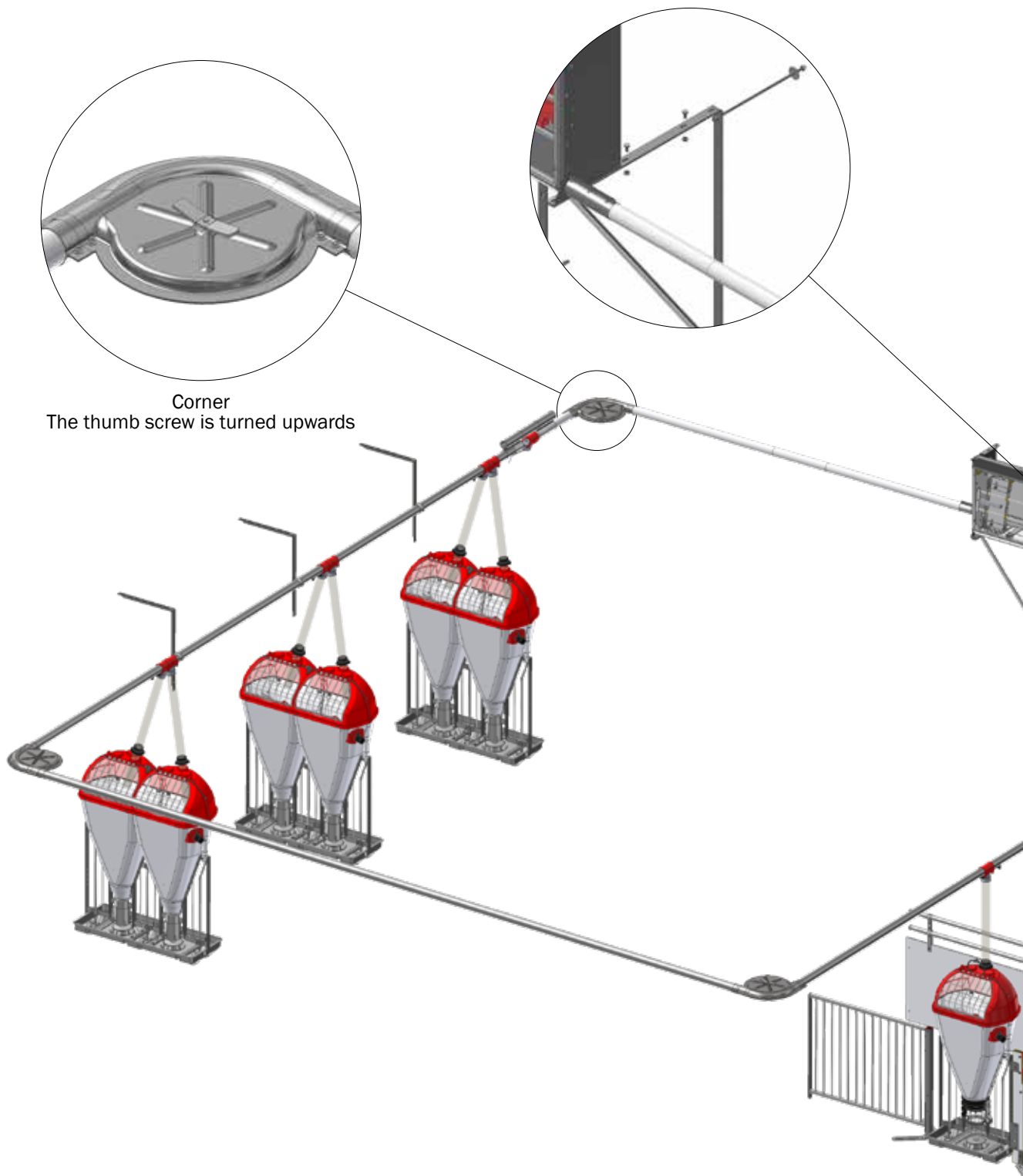

RULES FOR MOUNTING

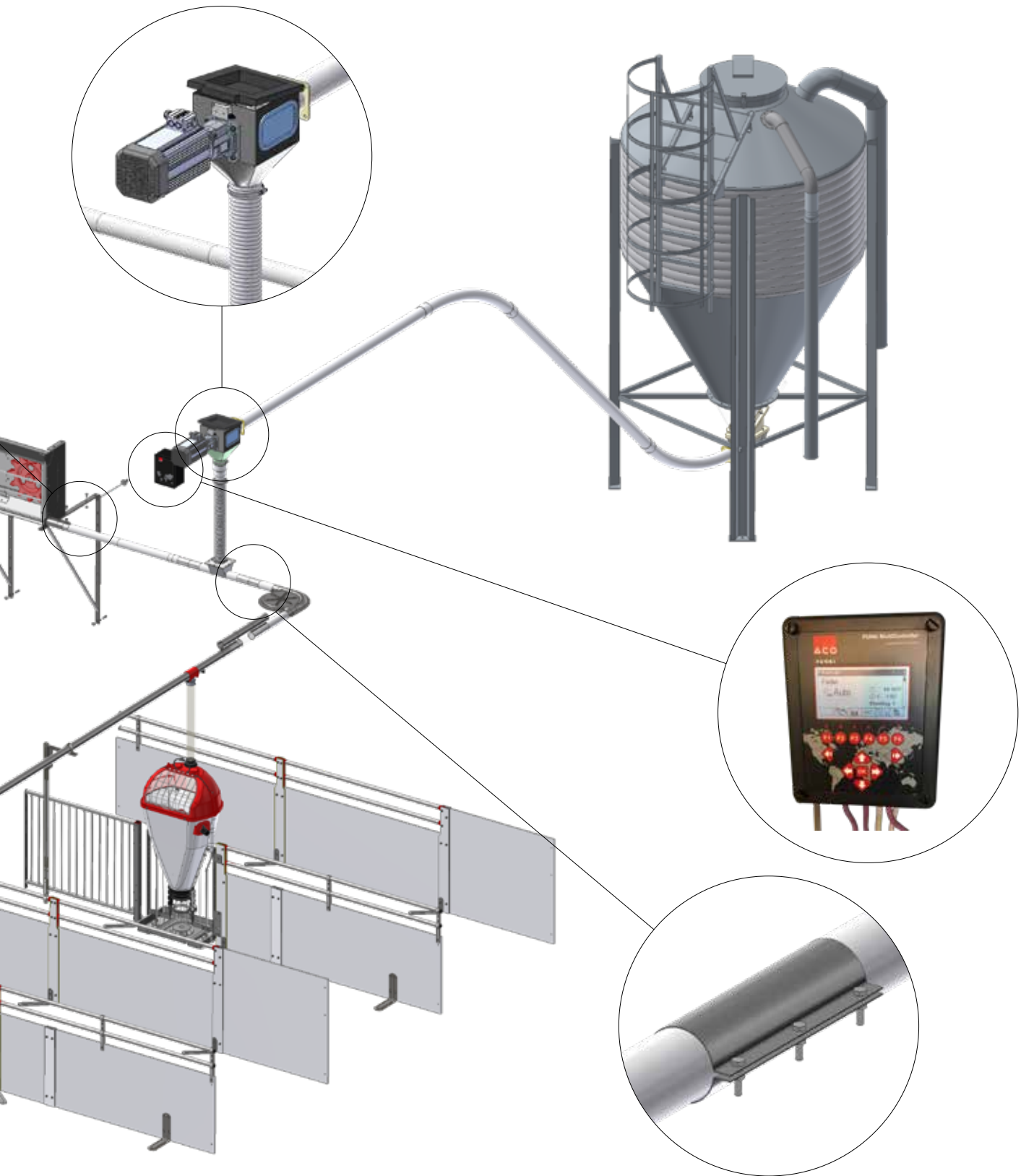

Union connector

MOUNTING

Feed pipes

Follow the instructions for handling and installing feed pipes. The feed pipes must be fastened with brackets to the ceiling, wall or post. It is important not to force or bend the pipes around obstacles. Check with a guide that the piping is mounted correctly, so that damage and wear on pipes and plastic plates is avoided.

If the pipes are passed through cold areas (eg outdoors), it is recommended to insulate the pipes through the cold area, to avoid condensation and hence coatings of feed on the inside of the pipes.

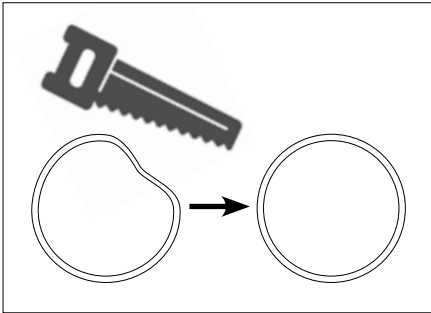

Deformed pipes must be trimmed. Use a trowel or angle grinder

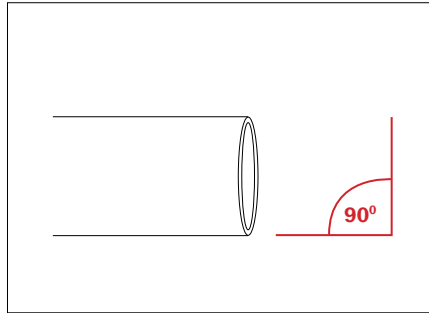

Saw the pipe completely perpendicular, and deburr inside and outside

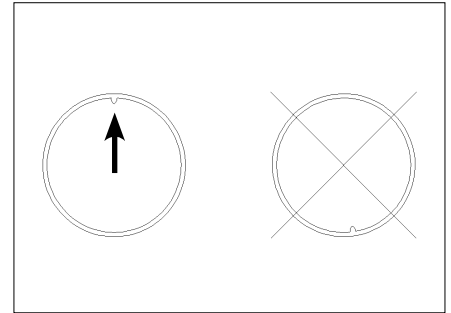

Turn the inner weld seam upwards

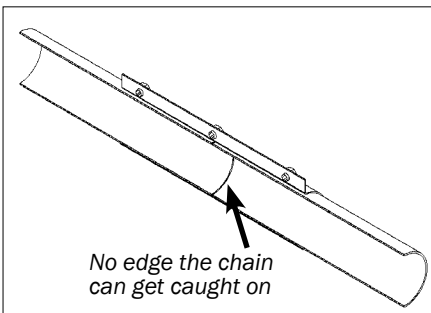

Assemble the pipes completely tightly using a union connector

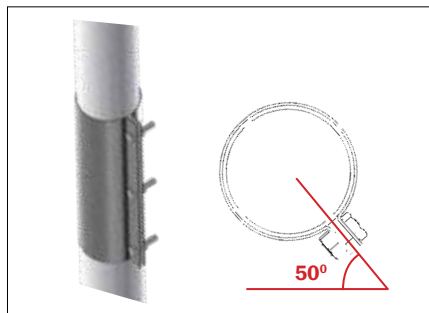

Place the union connector with the opening obliquely downwards - approx. 50° angle

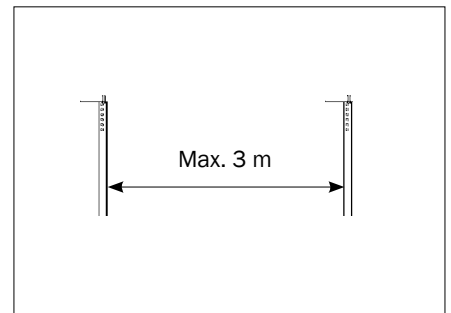

Support the pipes every 3 meters

Drive unit

The drive unit is best placed between the last feed outlet and the reception unit. See the direction of rotation in the picture.

The drive unit can be mounted on the floor, raised above the floor (adjustable legs) or mounted on the wall with shelf brackets.

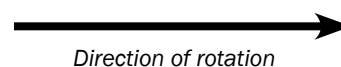
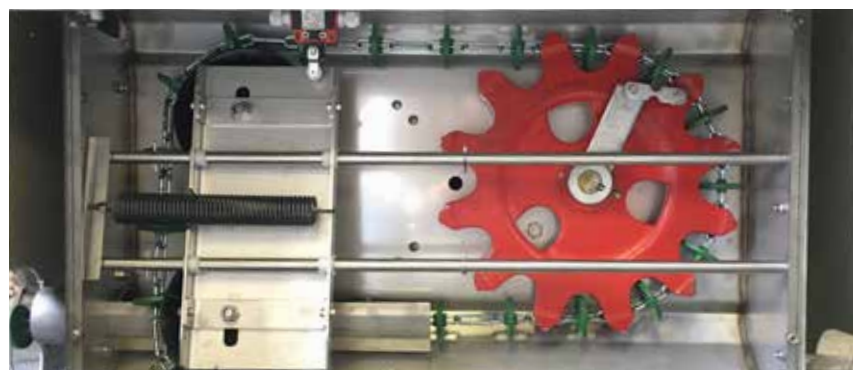

MOUNTING

Corners

To ensure an optimally functioning feed transport system, please be aware of the use of corners, as these can be an additional complication of the feed flow. Pay special attention to the feed angle when the feed is led up or down. In addition, Z-piping should be avoided as far as possible. If this is unavoidable, keep a distance between the corners of min. 2 meters.

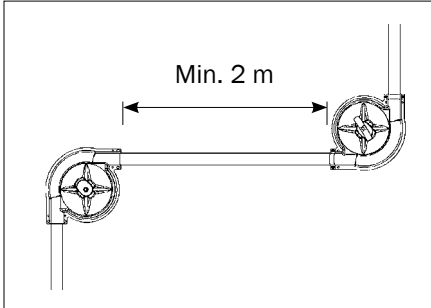

For Z-piping, the distance between the corners must be min. 2 meters

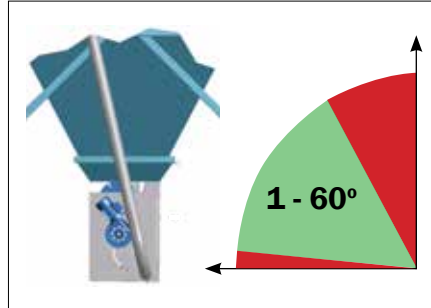

When the feed is led up or down, the feed angle must be 1-60°



The thumbscrew must face upwards

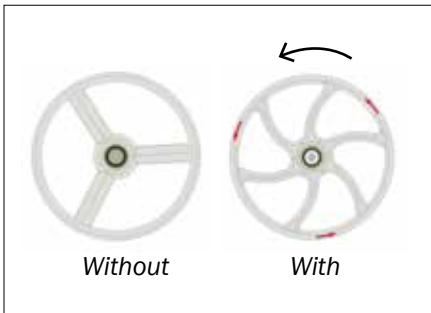

With/without predetermined direction of rotation

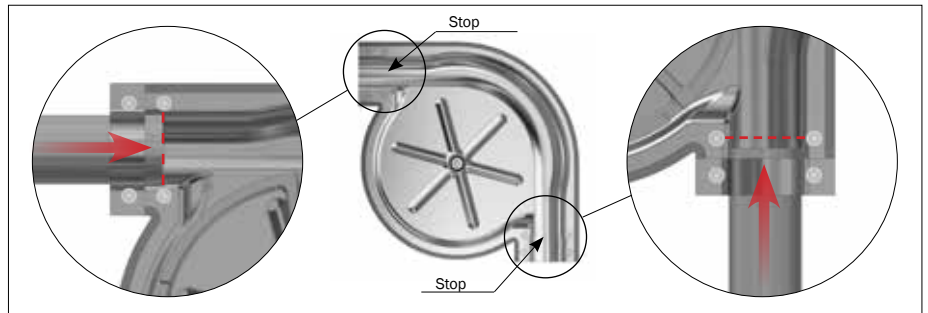

The feed pipe is pushed all the way to the stop in the corners

Feed outlet

When the feed line is assembled, mark the position of outlets and feeders. For each outlet, drill two holes offset from each other (use a conical drill). See the mounting instructions for the various feeders to find relevant specifications for hole sizes. Be sure to deburr the edge of the holes so as not to damage the chain.

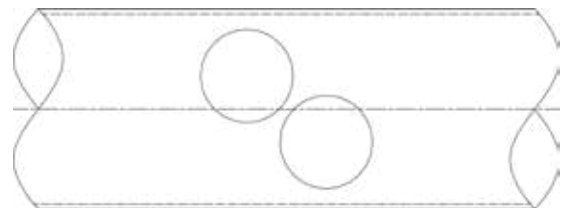

Reception unit

Read the user manual for the drive unit thoroughly before handling and installation!

Pay special attention to the safety instructions described in the user manual.



The reception unit contains parts that can be sharp and heavy. Wear work gloves and safety footwear when working with the reception unit.

The machine can start automatically. Always cut off the power on the main switch before servicing the machine!

MOUNTING

Chains

For feed transport, PowerLine or Master Chain can be used. It is important that the chain is inserted and turned correctly. For both types of chains, the system must run without feed with swivels attached for min. 2 hours after inserting the chain. This is to ensure that the chains are straightened. **However, this does not apply to 38 mm chains.**

See the PowerLine and Master Chain mounting instructions for further information on installing the chains.



Use swivels to straighten out the chains before starting the feed transport. Run with swivels for two hours.

PowerLine chain

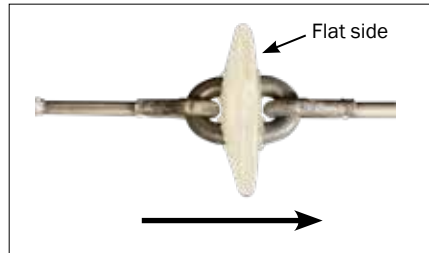

The flat side of the plates should face forwards, against the feed

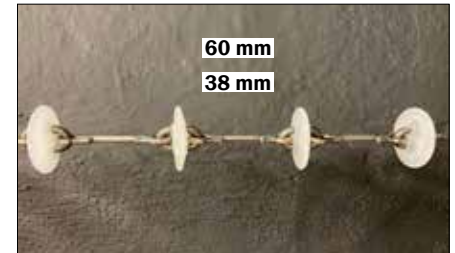

PowerLine chain sizes

Master Chain

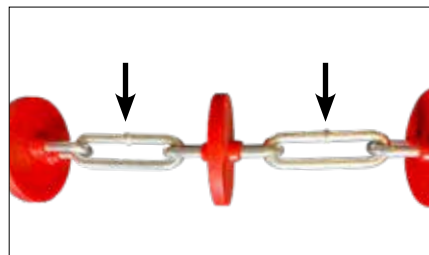

Make sure the weld joints on the links face away from the center of the drive wheel

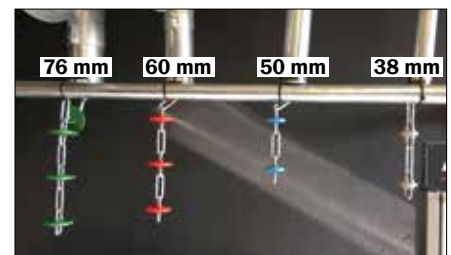

Master Chain chain sizes

Stop sensor / switch

The sensor is placed between the last feed outlet and the reception unit.

Place the sensor at least 2 meters from a corner, and in an angle of 30°.

The feed pipe must be supported immediately before or after the sensor to ensure that the feed pipe is completely straight so that the sensor can function optimally.

