

**ACO**

**| FUNKI |**





# ACO FUNKI

Your partner for the next project

Winner of Year's Performance 2018  
/ within the total Danish agriculture sector /

ACO FUNKI specializes in development and production of livestock systems for pig producers worldwide. ACO FUNKI is a professional company delivering full-line stable projects and has employees distributed in offices in Denmark, Germany, France, Spain, Poland, Russia, Ukraine and China.

We are part of the well-known German ACO Group, which has more than 4300 employees worldwide. In 2014, we acquired all the assets of Egebjerg International A/S, resulting in an even stronger product range.



## CONTACT OUR SALES TEAM



**GERMANY**  
Tino Holger Ulshöfer  
+49 4331 664 66 90  
tino.ulshoefer@aco.com



**FRANCE**  
Louis-Marie Audouit  
+33 607 120 465  
laudouit@acofunki.com



**SPAIN, PORTUGAL**  
Francesc Closa  
+34 935 650 727  
fclosa@acofunki.com



**LATIN AMERICA**  
Angel Tamayo  
+45 24 83 57 88  
atamayo@acofunki.dk

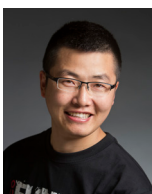

**CHINA**  
Robin Shan  
+86 13468298360  
rshan@acofunki.cn



**POLAND**  
Krzysztof Skwarek  
+48 256 83 15 98  
krzysztof.skwarek@acofunki.com



**ROMANIA, MOLDOVA, BULGARIA**  
Andrei Nanboe  
+45 2464 1696  
ananboe@acofunki.dk



**UK, IRELAND, SOUTH KOREA**  
Keld Bertelsen  
+45 40 26 63 70  
kbertelsen@acofunki.dk



**SOUTH EAST ASIA**  
Frank Andreassen  
+45 2497 2320  
fandreassen@acofunki.dk



**USA, CANADA, UKRAINE**  
Sergiy Panasyuk  
+45 40 32 39 00  
spanasyuk@acofunki.dk



**AUSTRALIA, ITALY, NEW ZEALAND**  
Rudi Hirsch-Emtkjær  
+45 2042 5004  
rhemtkjaer@acofunki.dk



**GLOBAL SALES**  
Torben Olesen  
+45 9626 9253  
tolesen@acofunki.dk

# TABLE OF CONTENTS

## 2 WELCOME TO ACO FUNKI

Contact

## 4 DANISH PIG PROJECT INSTITUTE

Project Delivery Model

## 6 LIQUID FEEDING

Dry feeding vs. liquid feeding

Liquid feeding tank

Residual-free liquid feeding

Liquid feeding systems

Components for liquid feeding

FUNKINET control

Sensor feeding with FEED MANAGER

Milling

Troughs

## 20 DRY FEEDING

BABY FEEDER

MASTER CHAIN + POWERLINE

Farm Management

FUNKI Phase Dry

FUNKINET Dry Section

FUNKINET Dry Single

FUNKINET Dry Multi

VD100 Floor Feeder

Combi Feeder

AD-LIB Feeder

Phase feeding of sows

VD2 + VD22 Feed dispensers

VD5 - VD6 Feed dispensers

3IN1 NX + FUNKIMAT Feeders

TUBE-O-MAT Feeder

Feeders in steel and plastic

Accessories and floor plates

## 40 EQUIPMENT FOR SOWS

Free Access Box

LD-box

MULTIBOKS COMFORT

JUMB-O-FINE box

Boar door

Barrier gates

Troughs, front piping and front gates

Winch system

Light

Stimulation for insemination

INN-O-FLEX equipment for sows

FUNKI Farrowing pen

INN-O-CRATE Farrowing pen



Heating lamps

Water supply for sows and piglets

WELSAFE Farrowing pen for loose sows

FT-30 Farrowing pen for loose sows

## 63 EQUIPMENT FOR WEANERS AND FINISHERS

CLEAN-O-FLEX

FUNKI FIBER

FUNKI FLEX

FLEXCOVER climate cover

PVC board profiles, profiles and plugs

Manipulating materials

## 73 FLOORING

Combination slats

Moving Floor

Polymer plates

Heating plates

Self-supporting cast iron slats

Still-Care rubber heating mat

Rubber mat for piglet nest

## 82 WATER SUPPLY

Water supply overview

Water level valve

Tilt trough

Sprinkling and soaking

Water valves

DRIK-O-MAT drinking cup

Accessories for floor mounting

## 88 FEED STORAGE

Galvanized silo

Fibre glass silo

## 90 WASH ROBOT FOR PIG STALLS

## 90 AKTIVA CARCASS WAGON

## 91 ACO FUNKI PROTECT

## 92 VISIT OUR SHOWROOM

## 92 SERVICE AND MOUNTING

## 93 DANISH PIG ACADEMY

## 95 ACO WORLD

# ACO FUNKI PROJECT MANAGEMENT

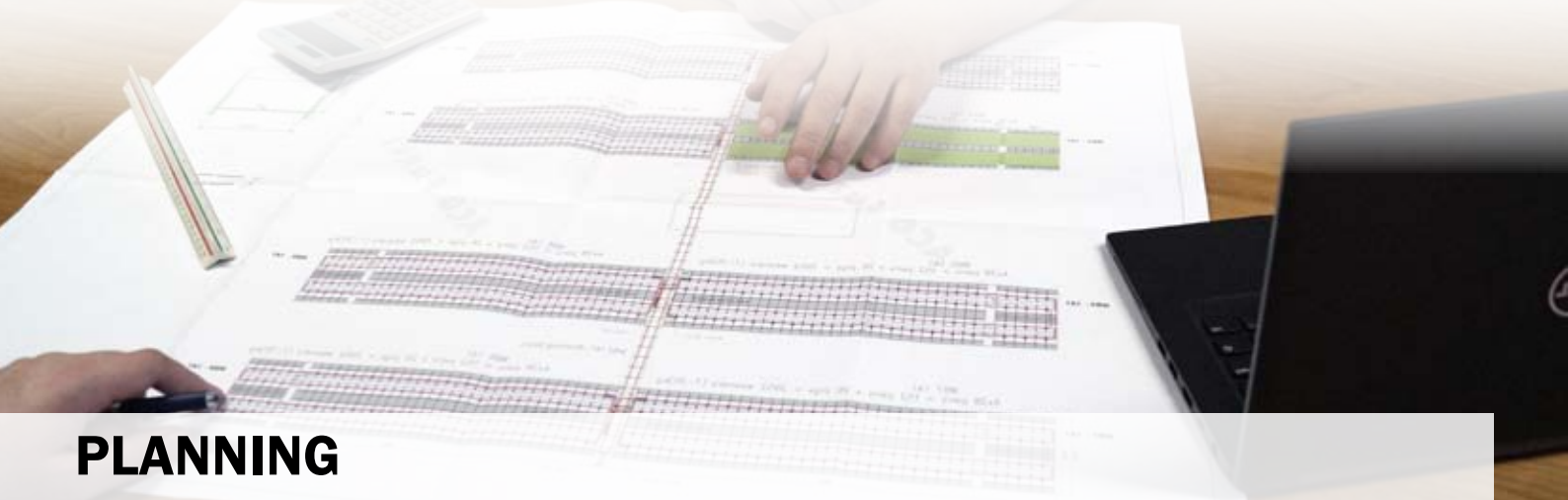

**PLANNING**



**INSTALLATION**



**HAND-OVER**



# PROJECT DELIVERY MODEL

Danish Pig Project Institute gives you the right farm layout with focus on biosecurity, best logistics, low production costs and high output of pigs as well as with focus on sustainable production methods.

### Our services:

- Master Plan
- Flow Chart
- Design overview
- Biosecurity installments
- Budget overview
- Financing

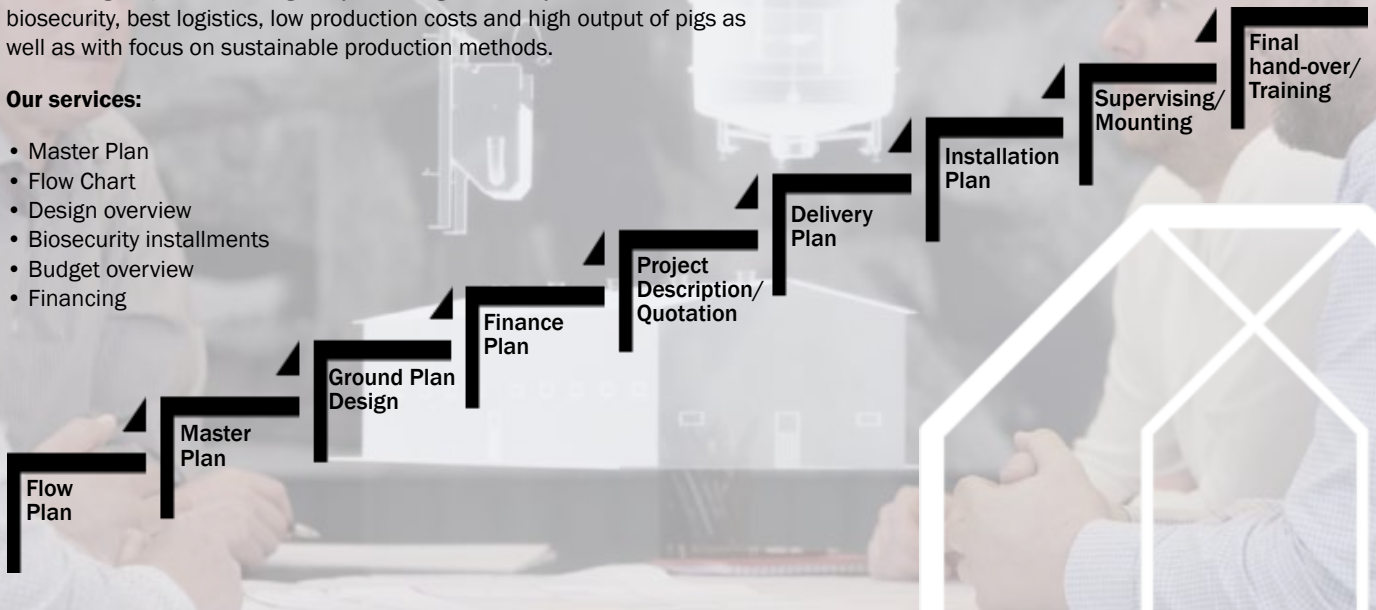

# TOTAL FARM CONCEPT

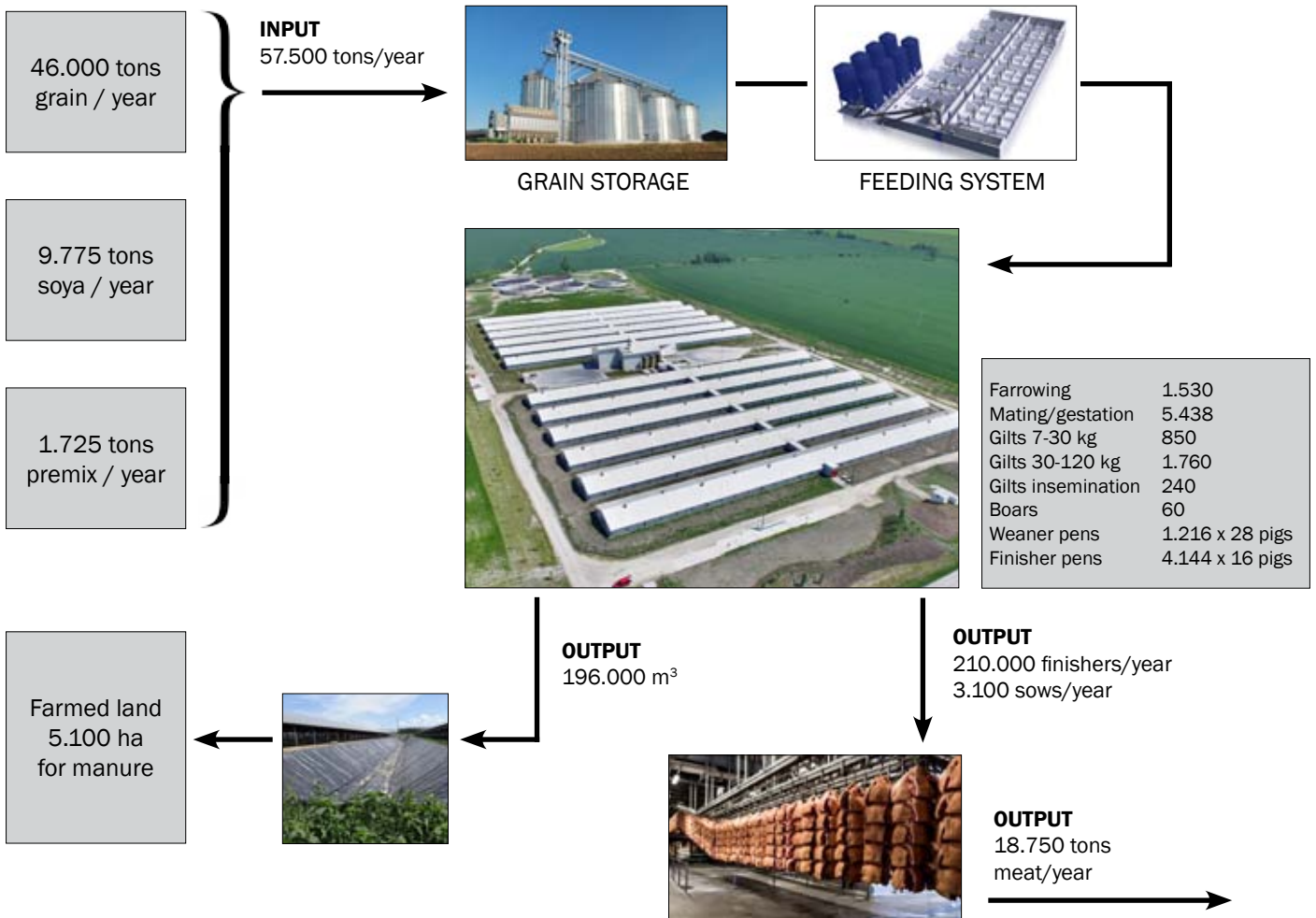

# LIQUID FEEDING

Always fresh feed, good overview, and ability to control feed allocation at the end of the pigs' growth period



# COMPLETE LIQUID FEEDING SYSTEM

Liquid feeding with high level of hygiene // FUNKINET control

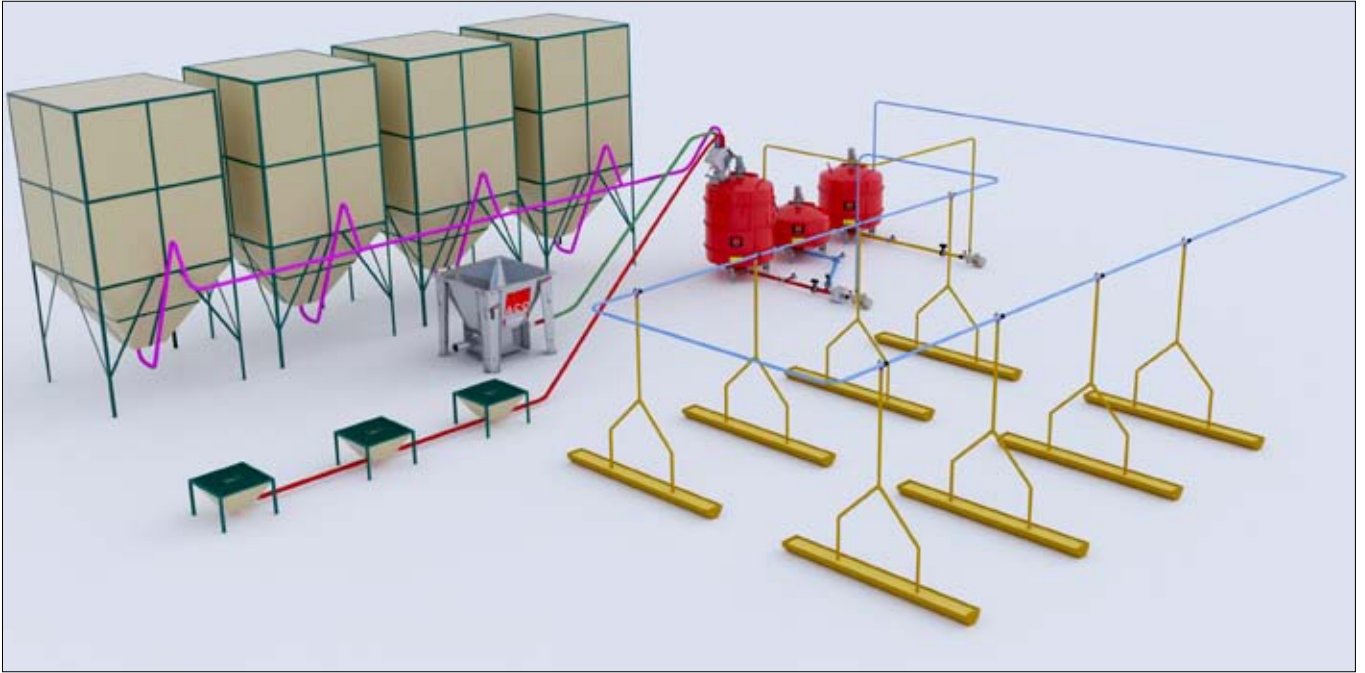

## Choose your system

### Dry feeding vs. Liquid feeding\*

Description	Dry feeding ad-lib	Liquid feeding	Difference per pig	
			Per day	30-110 kg
Daily growth, g	949	959	+ 10 g	1 kg
Feed conversion ratio, kg feed/kg gain	2,75	2,58	0,17 kg	13,6 kg
Meat percentage	60,6	60,9		+0,3%
Saved feed cost per pig				Up to 5,5 EUR/pig

### ◀ THE CHOICE IS YOURS

Feeding strategy and feeding method

Source: Note no. 1073, Danish Pig Research Center.

\*Home mixed flour feed



## BENEFITS AND RESULTS OF LIQUID FEEDING

- Higher feed intake and growth
- Lactic acid bacteria improve the gastrointestinal health
- Lower feed expenses
- Automatic feed allocation control
- Reduced risk of salmonella, and lower incidence of coli bacteria
- Improved feed conversion ratio - savings equivalent to 20 kg of feed per finisher
- Feed consumption up to 10% lower
- An increase in daily growth of up to 6%
- Achieve slaughter weight in less time

# LIQUID FEEDING

10% lower feed consumption with FUNKI LIQMIX mixing tank

ACO FUNKI offers residual-free liquid feeding system of a high quality. Advanced technology ensures an efficient investment. The main benefits of liquid feeding are fresh feed and good overview. Similarly, it is possible to use by-products from the food industry, as well as to manage feed allocation at the end of the pigs growth period. The liquid feeding is especially cost effective for finishers, because feed costs increase significantly. The liquid feed is easy for pigs to consumpt - especially for piglets. Good feed intake is a prerequisite for growth accelerating, so that the pigs reach slaughter weight in less time.

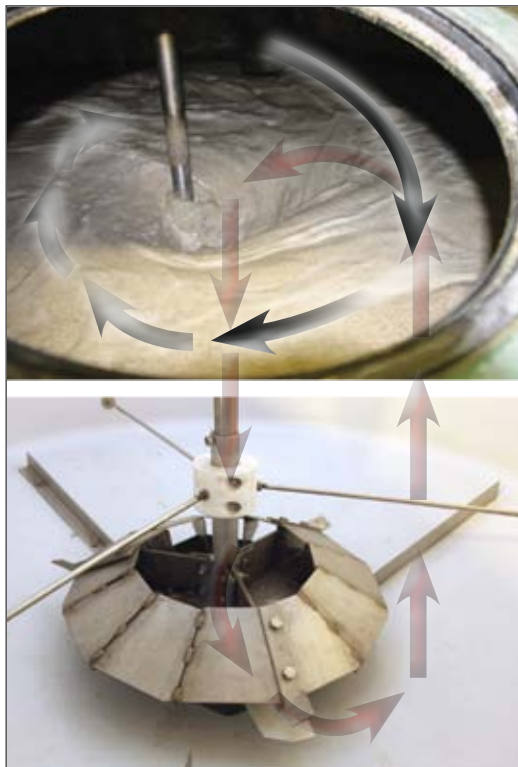

### ▲ FUNKI LIQMIX

The mixing tanks for liquid feeding are available with capacity from 2 to 10 tons.



## HIGH LEVEL OF HYGIENE IN THE LIQUID FEEDING TANK

### 1. Acid evaporator

Effective bacterial control with acid. Ensures high hygiene in the liquid feeding tank.

### 2. UV light

Prevents bacterial and fungal growth. Works optimally with well-functioning high-pressure systems.

### 3. High pressure cleaner

Rotary nozzle head that cleans the inside of the tank with high pressure water.

### 4. "Clean Feed Intake"

Self-cleaning component inlet for the wet feeding tank; with close shutter.

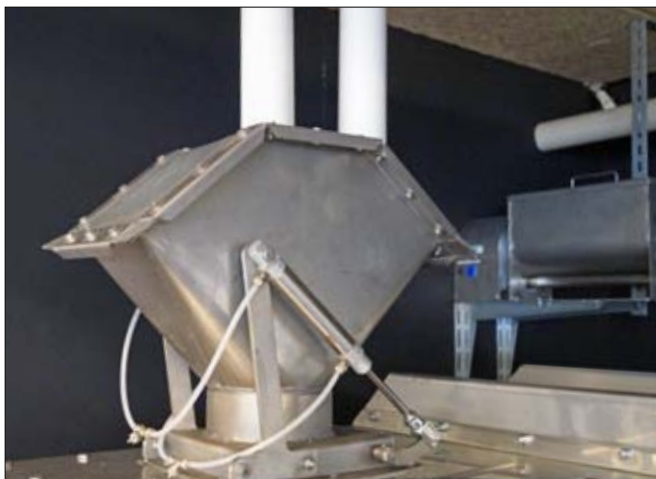
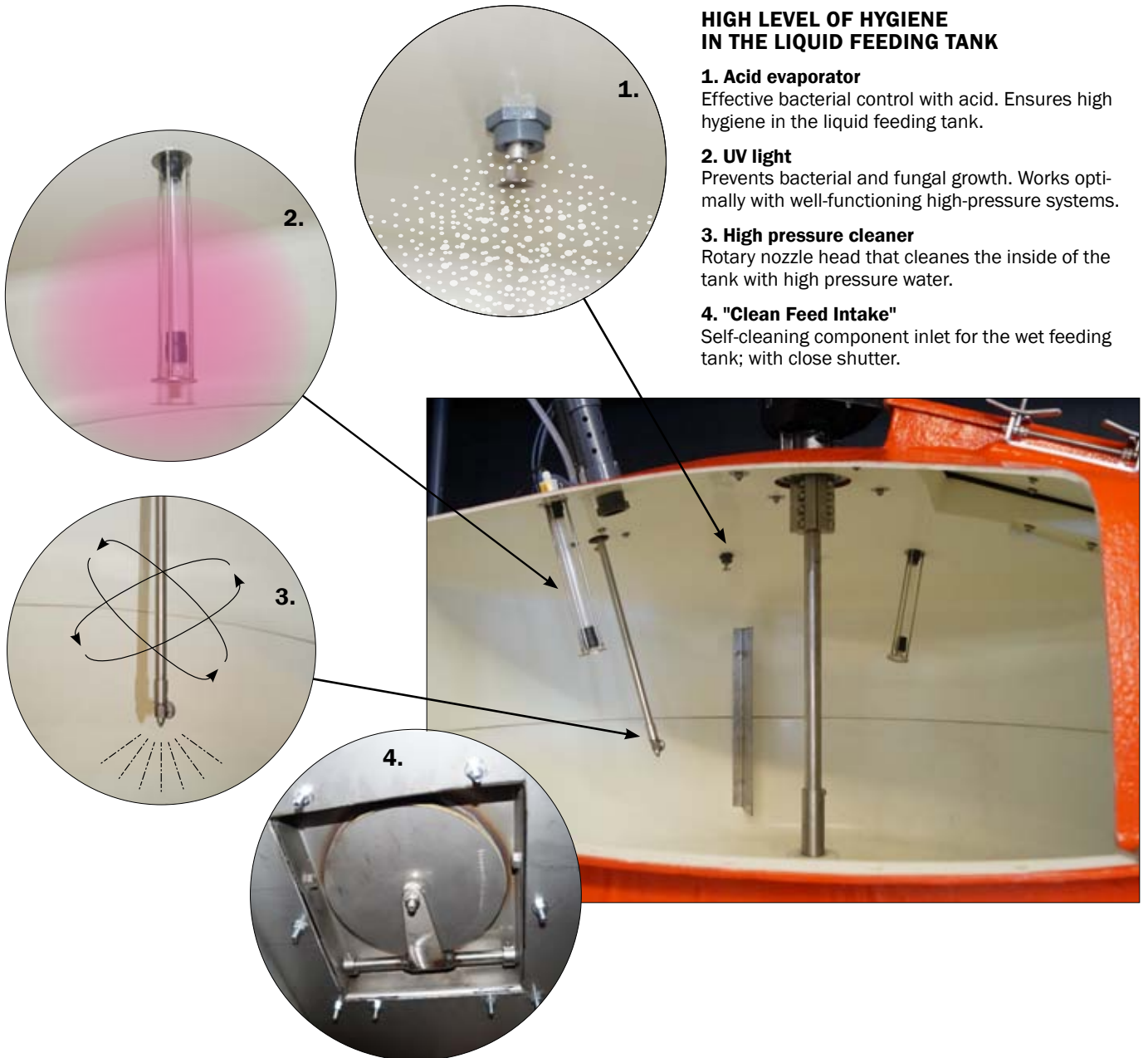

### ◀ COMPONENT INLET

The component inlet damper ensures that no moisture is penetrating the feed downpipe from the mixing tank. In addition, the component inlet is designed so the feed flow cannot be blocked.

# LIQUID FEEDING

Residual-free

## RESIDUAL-FREE LIQUID FEEDING

Residual-free liquid feeding is a feeding method that ensures no leftovers in the feed pipes after feeding. This ensures fresh feed for each feeding, and not a mixture of new and old feed.

- Increased number of weaned piglets with approx. 3 per sow per year
- Increase in piglet weight by weaning up to 1.2 kg
- Medicine consumption reduced by 50%
- No loss of amino acids
- Return on investment: 1-1.5 years

### BEFORE FEEDING ►

The mixing tank has the mixture ready. The tank for residual water is empty. The tank for clean water is full and there is clean water in the pipe line.

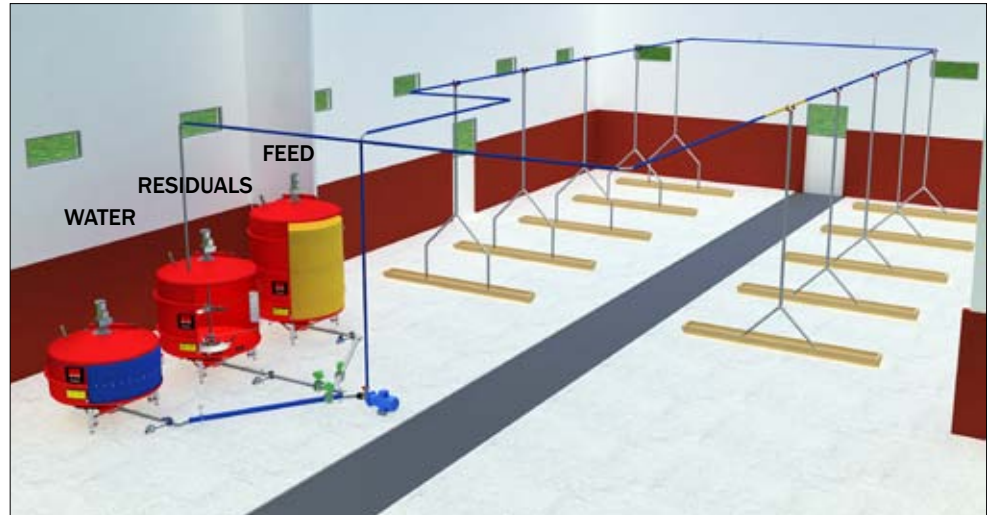

### DURING FEEDING ►

The mixing tank is emptied. The tank for residual water is filled. When there is no longer feed in the mixing tank, the water is pumped from the clean water tank. In this way, the clean water tank is used to distribute the feed left in the feed pipes, and when the last valve has been fed, the feed pipes are filled with water.

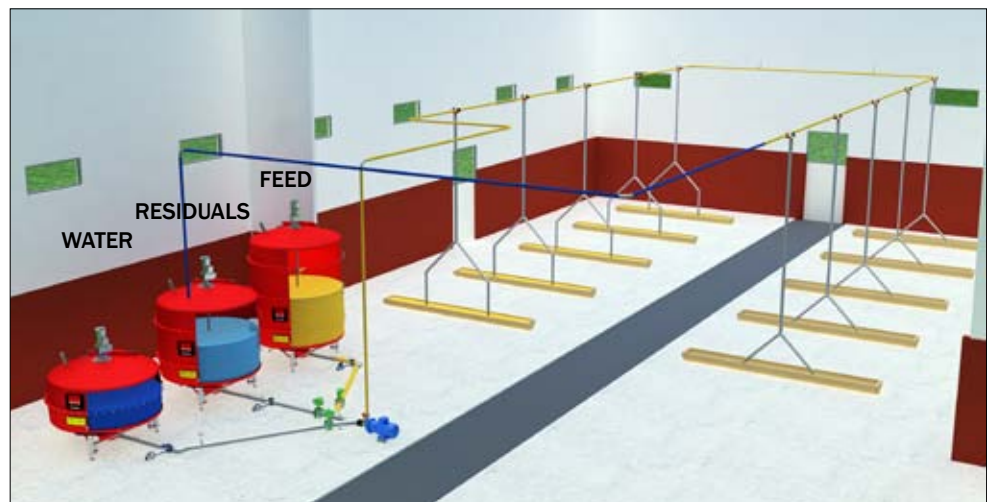

### AFTER FEEDING ►

The mixing tank is empty. The residual water tank is filled up.

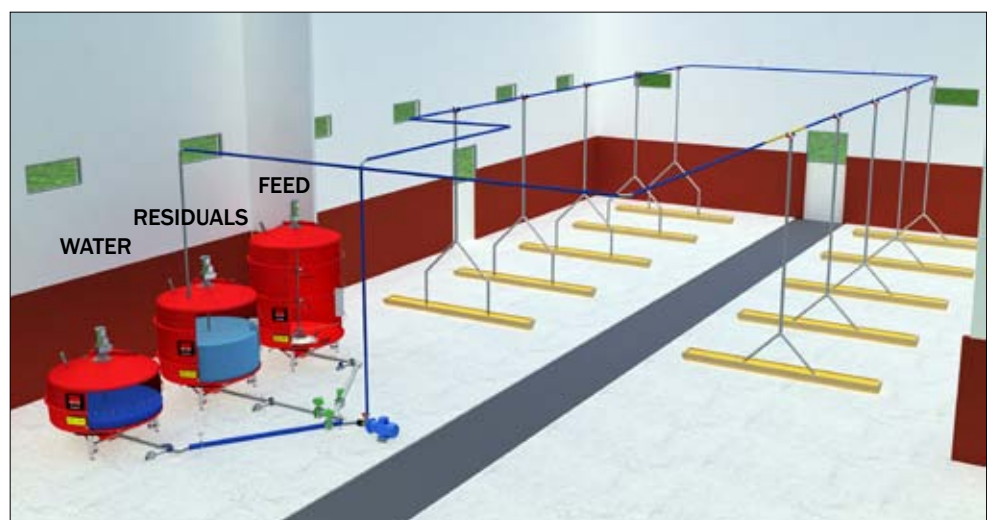

**CENTRAL PIPING WITH SECTION PIPES WITHOUT RETURN**

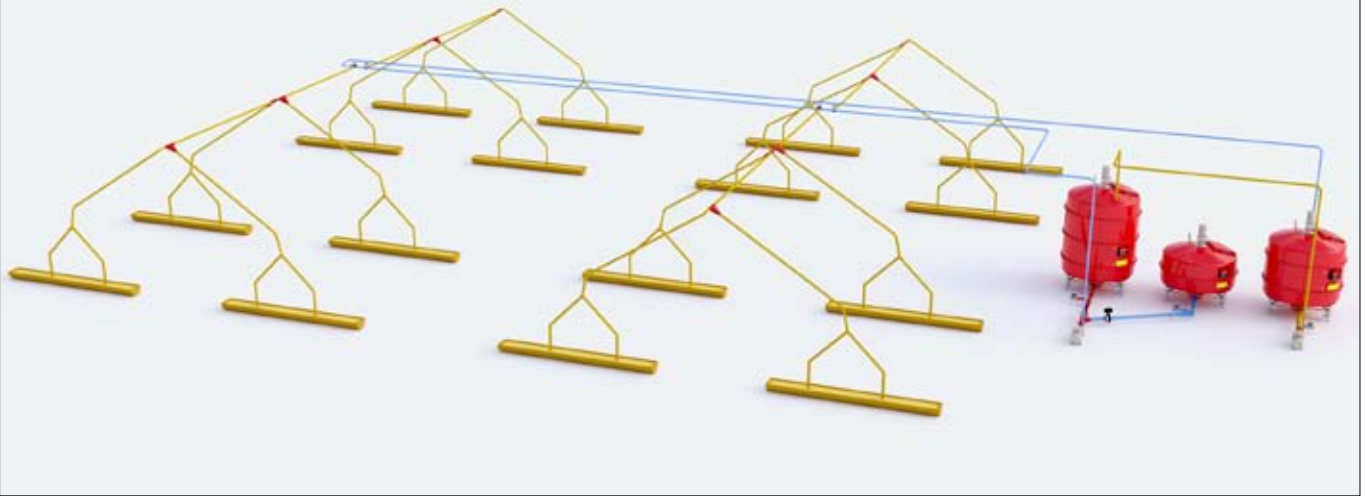

**CENTRAL PIPING WITH SECTION PIPES WITH RETURN**

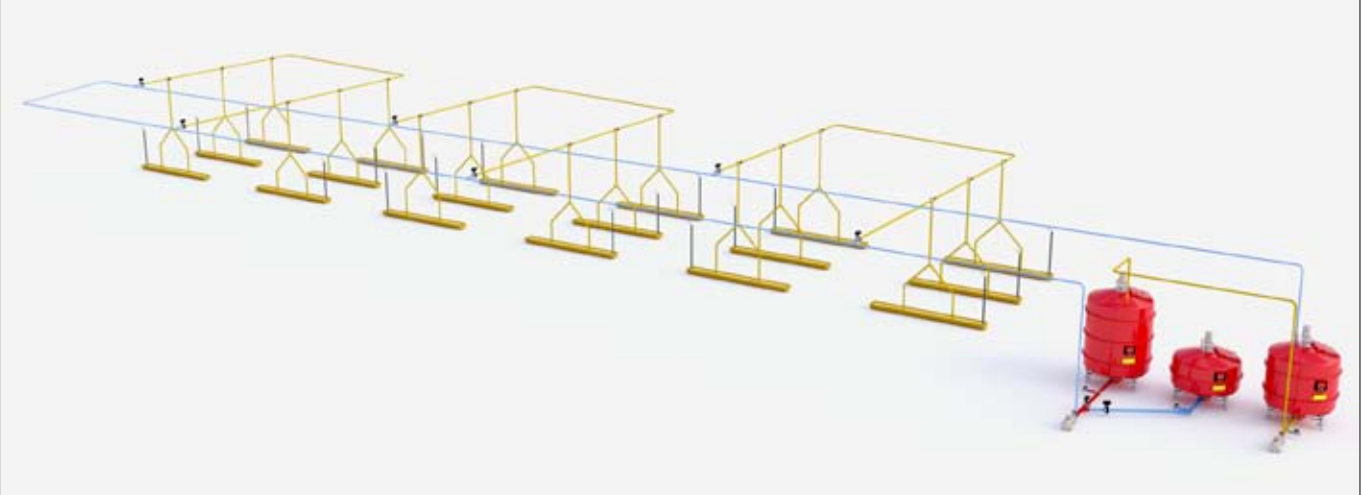

**AD-LIBITUM FEEDING FOR BOTH SOWS AND WEANERS**

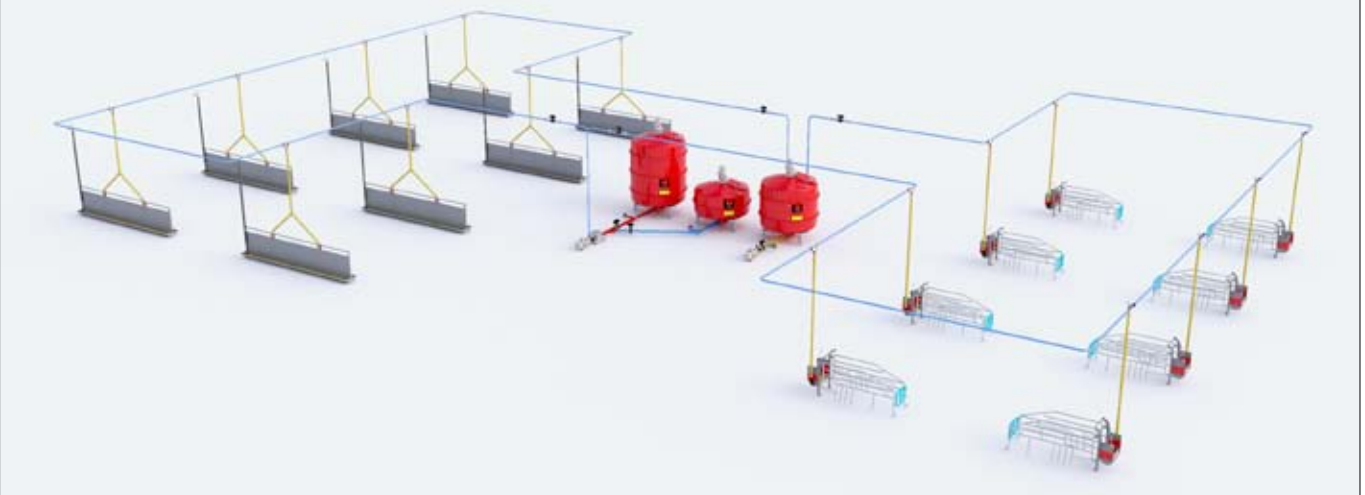



# COMPONENTS FOR LIQUID FEEDING

High performance equipment from silo to trough

If the farm staff spend more time on direct animal care, animal welfare and comfort will be reflected in financial performance at farm operation. Full automation of feed mix and feed distribution with ACO FUNKI's liquid feeding system releases more time for staff to pay attention to the animals.

## ◀ COMPONENT INLET AND CCM

CCM corn is a good feed ingredient for liquid feeding. From the CCM tank the corn "snails" directly into the liquid feeding tank. The mixing tank is available in different sizes, depending on the farm capacity. The design of the tank is critical for the feed quality. One of the most important criteria for feed quality is a uniform consistency and sufficient fluidity. These properties are obtained by appropriate mixing of the components in the feed mix.

Our mixing tanks are made of robust fiber glass. The tanks have completely smooth inner walls as well as a streamlined shape that prevents unwanted deposition of feed and ensures quick and easy cleaning.



## Testimonials:

“ We have 8.000 sows and produce 240.000 finishers annually. All our sows and finishers are fed by means of residual liquid feeding system from ACO FUNKI. We use CCM corn for all the animals. We now have 3 CCM plants with a volume of 20 - 60 m<sup>3</sup> each. The system runs smoothly daily.

Mogens Hansen, DanSlovakia

# COMPONENTS FOR LIQUID FEEDING

Microdosing system and feed valve



## ◀ MICRODOSING SYSTEM

The system dosates small amounts of vitamins, minerals and other additives with gram accuracy. The system is equipped with special stirring and has a capacity of 10 liters. The entire system is made of stainless steel.



## FEED VALVE ▶

- Optimal hygiene and no feed residuals
- Easy to mount
- Strong rubber membrane with long durability
- Stainless valve cover ensures that the valve stays tight
- Flexible - can be rotated in all directions



Ø50 mm = 1,56 kg feed/m



Ø63 mm = 2,46 kg feed/m



## ◀ TWIN-SPIN PIPE

- Made of strong PVC
- Good mixing effect
- Low pressure loss
- Good hygiene in the tube
- Ø50 / 63 mm



## ◀ STONE TRAP

When the feed flows from the mixing tank, it passes the stone trap. Here, small stones and other foreign objects are being sorted out. This provides additional protection for the pump. At the same time, the pigs get cleaner feed mix.

# COMPONENTS FOR LIQUID FEEDING

Pumps and acid pump



## ◀ PUMPS

ACO FUNKI's liquid feeding system uses electrical pumps for feed transport. This type of equipment is subject to great wearing-down due to the fact that it works almost without interruption. Unlike other pumps on the market, our pump has an advantage because it is made of stainless steel with a thickness significantly greater than other manufacturers'. This ensures a longer lifetime of the pump and a durable operation of the entire system.

- Centrifugal pump 4kw or 5.5kw
- Distribution speed 1-7 l / sec.

## TYPE OVERVIEW - PUMPS

Article	Description	Max Output Tons/hour	Feed output		Max pressure, Bar	
			Liter /min	Tons/hour	50Hz	60Hz
0138-689	Centrifugal pump for water <b>1,1 kW</b> , motor 380V, intake 2', outlet 1¼'	12	200	12	-	-
0139-120	Liquid centrifugal pump <b>4,0 kW</b> , 220/380V, intake 3', outlet 1½'	20	240	15	4,6	6,5
0139-138	Liquid centrifugal pump <b>5,5 kW</b> , 220/380V, intake 3', outlet 1½'	25	360	21	4,8	7,2
0300-125	Worm pump arr. nemo <b>4 kW</b> 2-step 2kW, intake PVC Ø90 mm, outlet PVC Ø63 mm	15	150/270	9/16	-	-



## ▲ ELECTRONIC ACID PUMP WITH WATER INTAKE

Automatic dosing of acid and medicine in water intake for, e.g., the water tank.



## ▲ HELICAL ROTOR PUMP



## ◀ ▲ ACID- AND SOAP PUMP

- Intake capacity - approx. 1 kg./min
- Can intake at time intervals
- The pump is durable and designed to resist for example acid

Full automation of feed mixes and feed distribution with ACO FUNKI's liquid feeding system releases more time for staff to focus on the animals.

You can specify a feed program for the entire growth period (up to 99 programs). The system mixes and transports feed according to the selected recipes, and can be adjusted at sectional and valve level. As the animals grow, the feed recipe changes automatically.

FunkiNet monitors the mixing process, distributes feed, and provides analysis of the processes and results.

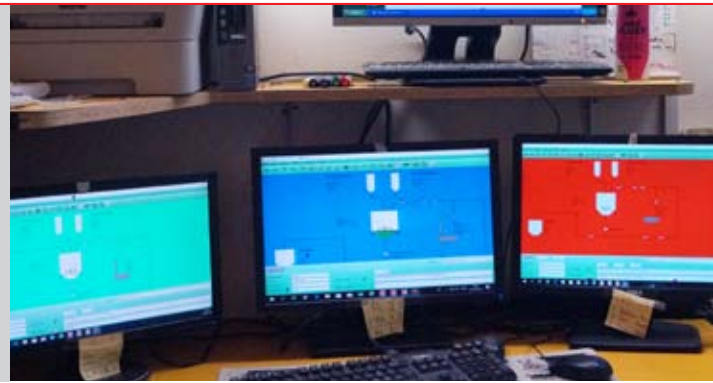

## ▼ CURVES FOR MULTI-PHASE FEEDING



## FUNKINET TO-GO APP

Management in pocket size

- Possibility to remote control the process
- Control data for each pen
- For Android OS
- For tablet or smartphone
- Ability to receive SMS for system failures (connection up to 10 devices)

## ▼ FUNKINET AUTOFEED - PROGRAM TIMES

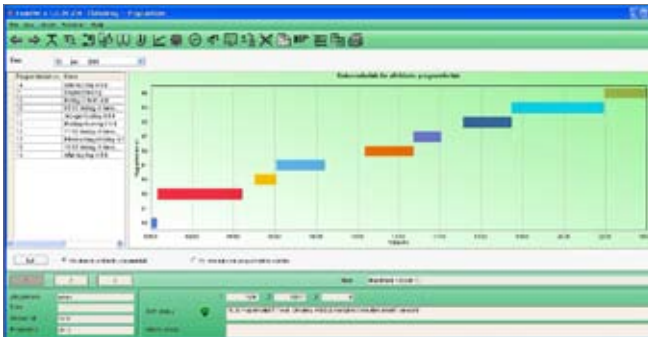

## ▼ MIXES WITH PROTEIN ADJUSTMENT



## FUNKINET FARM DATABASE

Collects data in a shared database

- Full traceability
- Overview of components, mixtures and nutrients
- Data extracts on farm, batch, section and pen level
- Optional periodically read-outs
- Database with data from every day back in time
- Batch reports with all relevant data
- Optimal overview
- Easy to operate
- Possible to track feed batch from delivery to trough

# LIQUID FEEDING

Sensor feeding with FEED MANAGER

**FEED MANAGER** - ensures the animals get the correct amount of feed.

With ACO FUNKI's FEED MANAGER, you have an intelligent system that automatically adjust the amount of feed, depending on time pigs spend on eating. The special sensor is placed in the trough to register how fast the pigs eat. The principle is simple: there are settings for the optimum eating time. If the pigs eat slower, they get less feed next time. If the pigs eat faster, they get more feed next time, though up to a maximum amount. Fully automatically system that ensures more rational use of feed.

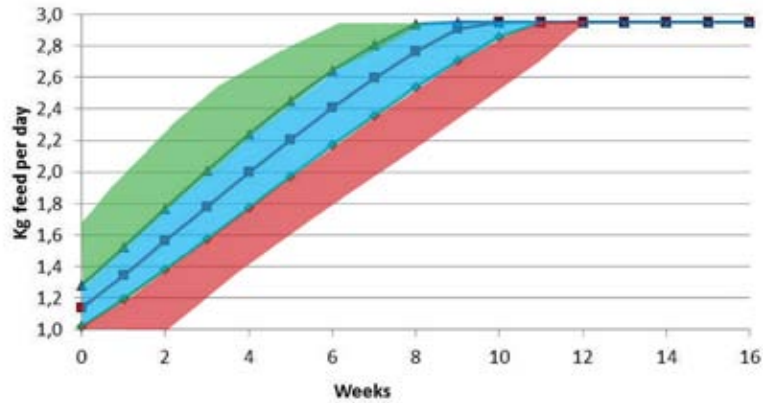
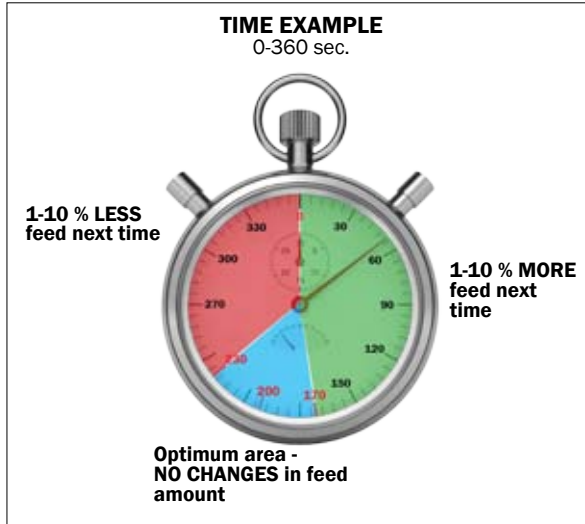

### ▲ SENSOR

The FEED MANAGER's sensor detects how long it takes before the feed is eaten up.



### Testimonials:



*It is very reassuring to know that the system can detect how quickly the pigs eat, and then adjust the amount of feed according to the feed curve. We have experimented with the parameters in the feed curve and have now found an optimal solution. The system is very flexible and has many options for optimization. Based on our experience, we have now decided that Feed Manager will be used in all our stable sections in the future.*

*Jørgen Krøjgaard, Herning, Denmark*

### Production results:

- 2,62 FU/kg growth
- 1007 gram daily growth
- 1,3% mortality
- Meat percent: 60,5





# FUNKINET MILLING

## Different options

With FunkiNet milling, you get the optimum overview; at the same time, consumption and mixes are shown in the same screenshot as your feed plant. And with up to 50 feed recipes and silos, you are secured far into the future, regardless of the capacity of the mill. With your own mill, you will have the opportunity to quickly adjust the feed mixes and get better welfare for your animals.

ACO FUNKI offers milling solutions of all sizes and functionality, according to your wishes and requirements.

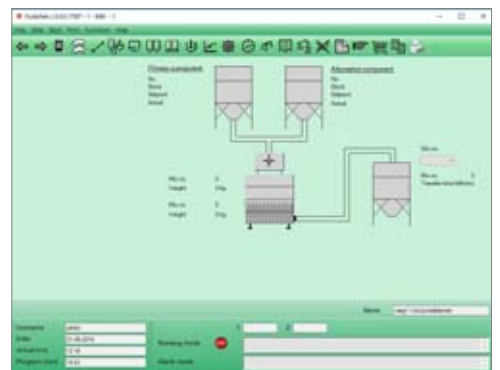



# TROUGHS

Made of polymer concrete or stainless steel

## Polymer concrete troughs

The troughs made of polymer concrete have a smooth surface that is very practical and hygienic. The troughs are resistant to influence of chemicals, feed and waste products.

### TYPE OVERVIEW - TROUGHS MADE OF POLYMER CONCRETE

Article no.	Description	For	Dimensions (HxWxL) (mm)	Volume (l/m)
02564	Trough TS 25	Weaners and finishers	143 x 300 x 1000	22
01605	Trough TS 30	Weaners and finishers	155 x 330 x 1000	32
01667	Trough TS 35	Sows	168/218 x 390 x 1000	38
02571	Trough TS 36	Sows	180/300 x 410 x 1000	42
03191	Double trough TS 41	Finishers	180 x 460 x 1000	50
01585	Double trough TS 47	Finishers	180 x 530 x 1000	55
02101	Double trough TS 50	Finishers	180 x 580 x 1000	65
18444	Trough TS 28 V	Sows	150/220 x 300 x 1000	30

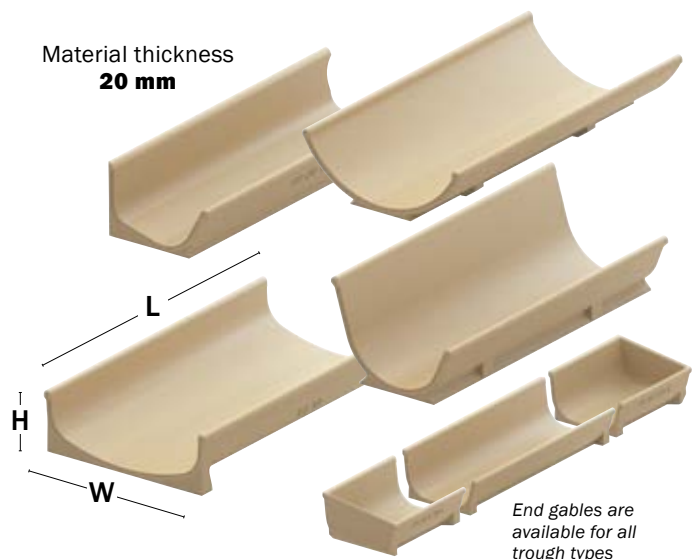

# TROUGHS

Stainless steel troughs

- Everlasting: made of stainless steel
- Minimal feed waste: inverted edges
- Hygiene and animal welfare: The edges are rolled on the outside so the surface is smooth on the inside. Minimising the risk of accumulation of feed remains and injuries to the animals
- Flexibility: Individually adapted length from 60 to 600 cm
- Cheap assembly: Easy handling, as the troughs are lighter than concrete
- Easy to clean: The troughs are elevated from the floor, allowing washing underneath them

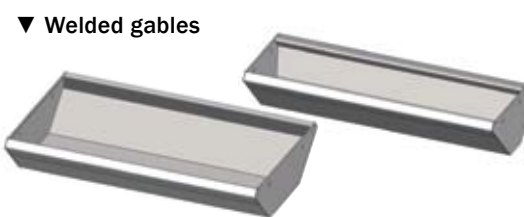

## STAINLESS STEEL TROUGHS for all box types and INN-O-FLEX (Length 0,6 - 6 m)

Article	Description	Volume (l/m)	Height	Upper width	Lower width
96180	For boxes with front bars	32,5 liter	14,3 cm	32,5 cm	11,5 cm
96181	For boxes with front gate	32,5 liter	14,3 cm	32,5 cm	11,5 cm

## STAINLESS STEEL TROUGHS for INN-O-WALL (Length 1 - 6 m)

Article	Description	Volume (l/m)	Height	Upper width	Lower width
39234	Double trough for Wean-to-Finish, finishers and gilts	49 liter	14,5 cm	49,7 cm	20 cm
39211	Single trough for Wean-to-Finish, finishers and gilts	24,5 liter	14,5 cm	24 cm	7 cm
39215	Double trough for weaners	38 liter	12 cm	43 cm	20 cm
39218	Single trough for weaners	16 liter	12 cm	20 cm	6 cm

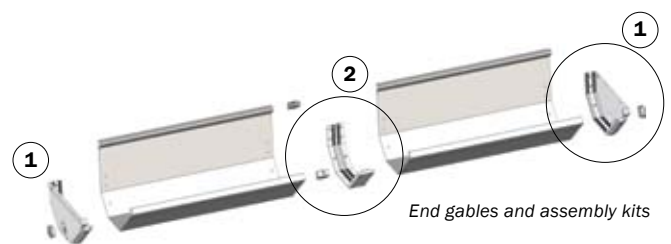

## ACCESSORIES for stainless steel troughs

Type	Description	Article
End gables and assembly kits	End gable PVC for 1 trough	1 31025
	Assembly kit PVC for 1 trough	2 31030
Wall brackets	For single trough against wall	3 31050
	For single trough single against PVC board profile	4 31051
	For single trough double against PVC board profile	5 31052
Foot brackets	Foot bracket and support leg, double trough, weaners	6 31002
	Foot bracket and support leg, double trough, finishers	6 31000
	Foot bracket, single trough, finishers	7 31001
	Foot bracket, single trough, weaners	7 31003
	Adapter for support leg, 35 mm PVC board profile	8 30053



# DRY FEEDING

Accurate feeding, traceability, lower feed costs, reduced environmental impact and latest technologies characterize ACO Funkis dry feed solutions



**FEEDERS**



**FEED DISPENSERS**

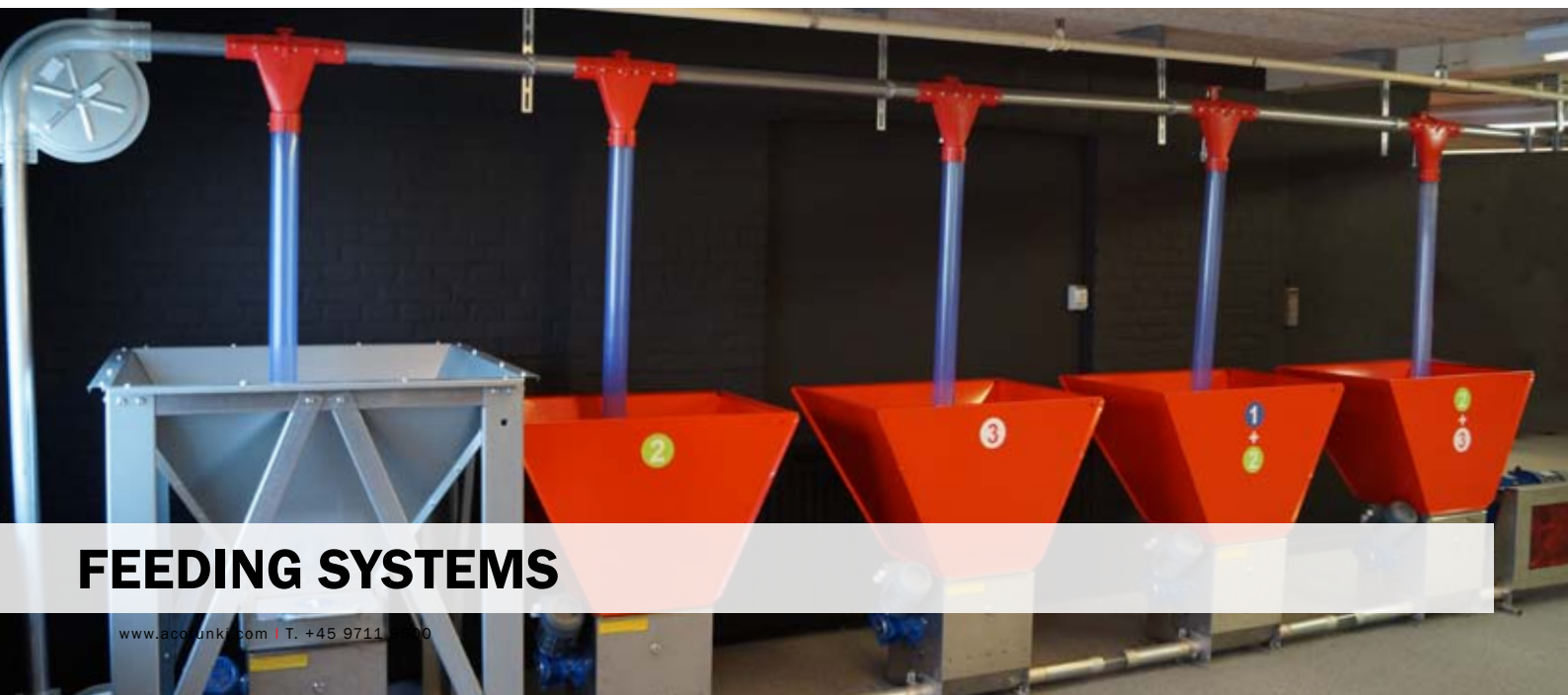

**FEEDING SYSTEMS**



- The best start for pigs after weaning
- Increases feed and water intake
- Stimulate the piglets to eat and drink
- Ensures optimal growth
- Fills the trough when the sensor indicates it is empty
- Always fresh feed and water
- Easy to clean
- Reliable and easy to operate
- Adjustable pause time from emptying to feed assignment
- Possibility to adjust water volume
- The trough is designed for pigs from 4 kg
- Up to 60 pigs per feeder

# BABY FEEDER®

Unique mix of feed and water. For pigs from 4 kg

## Feeder with sensor

Baby Feeder is a feeder that can be used by even the smallest pigs from 4 kg. The unique design of the feeder makes it possible to mix feed and water inside the trough, which ensures better hygiene and cleanliness. Feed automatically fills when sensor indicates that the trough is empty.

## Trough

Our Baby trough is long, and it makes it easy to build it between the partitions in a pen. The trough dimensions, front height and width are adjusted to the smallest pigs.



Feed automatically fills when sensor indicates the empty trough

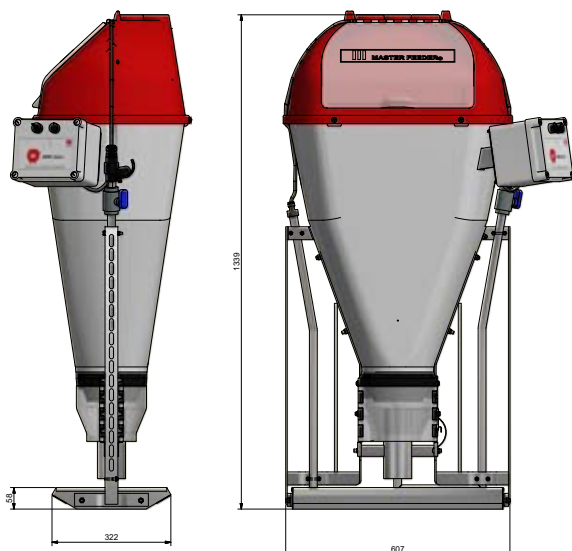

Water and feed are mixed in the bottom of the trough



ACO FUNKI CHAIN PROGRAM	
38 mm	400 kg/hour
50 mm	700 kg/hour
60 mm	1000 kg/hour
76 mm	2000 kg/hour
100 mm	6000 kg/hour
160 mm	21000 kg/hour

# MASTER CHAIN + POWERLINE



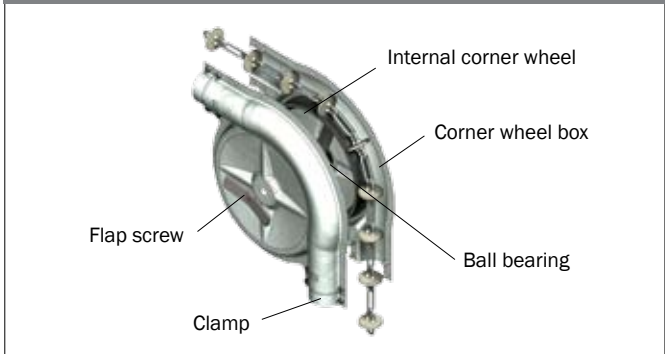

## Dry feeding system

### CORNERS



ACO FUNKI's corners are optimized for extra long durability

- No moist percolation or feed waste - deep drawn corner wheel boxes and weather strips that guarantee tight and strong corners
- Strength and durability - corner wheels in cast iron and with ball bearings
- Minimum risk of chain breakage - extra wide contact face
- Minimum risk of working interruptions - the spokes of the corner wheel are designed for the least resistance as possible and are applicable for one way as well as for reversible systems

Corners	
<b>For 38 mm system</b>	
Corner for 38 mm system	
<b>For 50 mm system</b>	
Corner for 50 mm system	
<b>For 60 mm system</b>	
Corner for 60 mm system - galvanized	
Corner for 60 mm system - stainless steel	
<b>For 76 mm system</b>	
Corner for 76 mm system	

300 metres chain and maximum 12 corners. For every corner less 10 metres of chain can be added. Likewise, 10 metres of chain is deducted for every corner added.

NB: There is a maximum of 24 corners per drive unit.

### CHAIN AND WIRE



#### ▲ POWERLINE® - extremely strong lightweight chain

- Strong and durable - PowerLine is made of two types of specially hardened steel that ensures long durability
- The PowerLine chain is quality tested between each joint - self-emptying drive unit that easily releases the chain

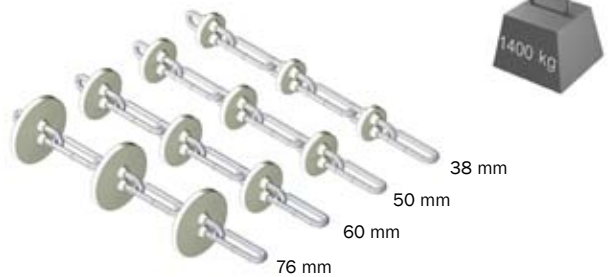

#### ▲ MASTER CHAIN®

- Minimum wear and tear of the system, easy to mount - 20% lighter than other chains
- The construction ensures minimum twist of the chain - optimized dependability
- Durable - hardened and galvanized. Nylon - very strong plastic material



## ▲ "COMPAC" DRIVE UNIT - for transportation of pellets and meal

- The drive unit is equipped with a large aluminium drive wheel that ensures stable and steady operation with minimal wear and tear on the plastic discs.
- The drive unit is equipped with a slanting, self-emptying base, which means that the amount of animal feed accumulating in the machine is very limited.
- The cabinet is made of stainless steel in a compact design that enables optimum fitting to a wall or directly onto the floor.
- The accompanying sight glass ensures that the filling ratio of the feed in the system can be optimally regulated.
- Easy to maintain. Standard motor, few parts that wear off.

## RECEPTION UNIT

Ø 38 / 50 / 60 / 76 mm



Reception unit - stainless or galvanized steel.

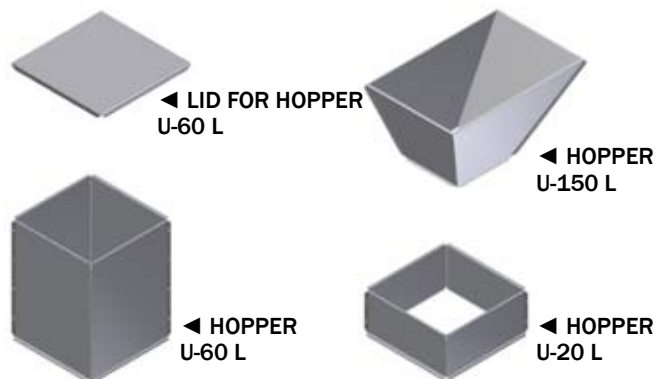

### ▲ RECEPTION UNIT

The reception unit is the heart of the feeding system and is crucial to the dependability of the feeding system and the life span of the chain or wire. The reception unit controls how even and how much feed is dosed into the feed string.

ACO FUNKI's feeding system is also available for filling with flex auger.



### ◀ CONNECTOR

Ø38, Ø50, Ø60 and Ø70 with option for a shutter to open and close.

## FLEX AUGER

### ► FLEX AUGER

Reliable and strong, with long durability.



TYPE	LENGTH	CAPACITY
Ø 75	6 - 50 m	800 kg/h
Ø 90	6 - 42 m	2400 kg/h



# FARM MANAGEMENT

FUNKI APP - SLOW FEEDING BIOMIX

## FUNKI MULTI CONTROLLER



### ◀ FUNKI MULTI CONTROLLER Dry feeding control for ad-libitum feeding

- Up to 4 different silos and 5 pipe strings
- Pipe lines: simultaneously
- Pipe lines: following one another
- Pipe lines: with overlap

### ▶ COMPUTER INTERFACE

- Good overview
- Easy to use
- Access from office
- Online access



## FUNKI APP



FUNKI App allows you to manage your stable's computers with your smartphone or tablet.

After installing software on your device, you can connect to FUNKI computers in the stable via Internet and SmartLink-RM. Then you have control over them.

The screens and buttons in the App are the same as in the FUNKI computer.

This results in recognizable user interface and ensures fast and precise management of the stable computer - wherever you are.

## SLOW FEEDING BIOMIX FOR GESTATING SOWS

- Ensures that the sows are calm during feeding
- No stress related to competition for the feed
- More live born piglets
- No feed waste, as the feed rate is adjusted to the sows' speed
- The system is extremely reliable and has high capacity
- Small investment

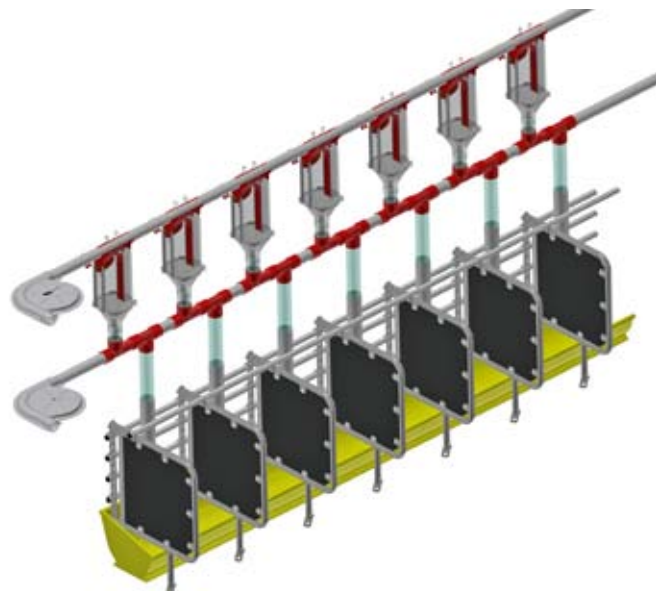



## FEEDING CONCEPT



- Control up to 4-5 silos
- Feed pipe strings or control devices for each controller

## SILO & CORN CONTROL



- Measures feed consumption
- Weight under silo
- Scale on feeding circuit for each section

## FUNKI MULTI CONTROLLER

Feeding - silo - water - light - winch system

- All-in-one network
- Overview - in one PC program
- Control via tablet/smartphone
- Online support



## WINCH SYSTEM

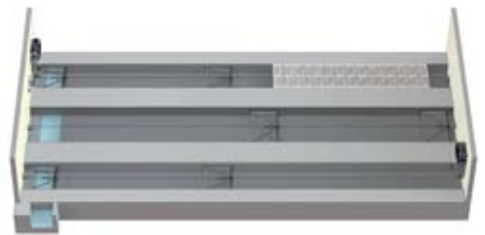

- Control of winch system

## WATER CONTROL

- Daily water consumption
- Good overview of the pig's performance
- Early warning of problems
- Higher yield



## LIGHT CONTROL

- Light program adapted to the needs and welfare of the pigs
- Energy savings
- Optimal workflow



## ▼ FUNKI PHASE DRY

Phase feeding of weaners and finishers

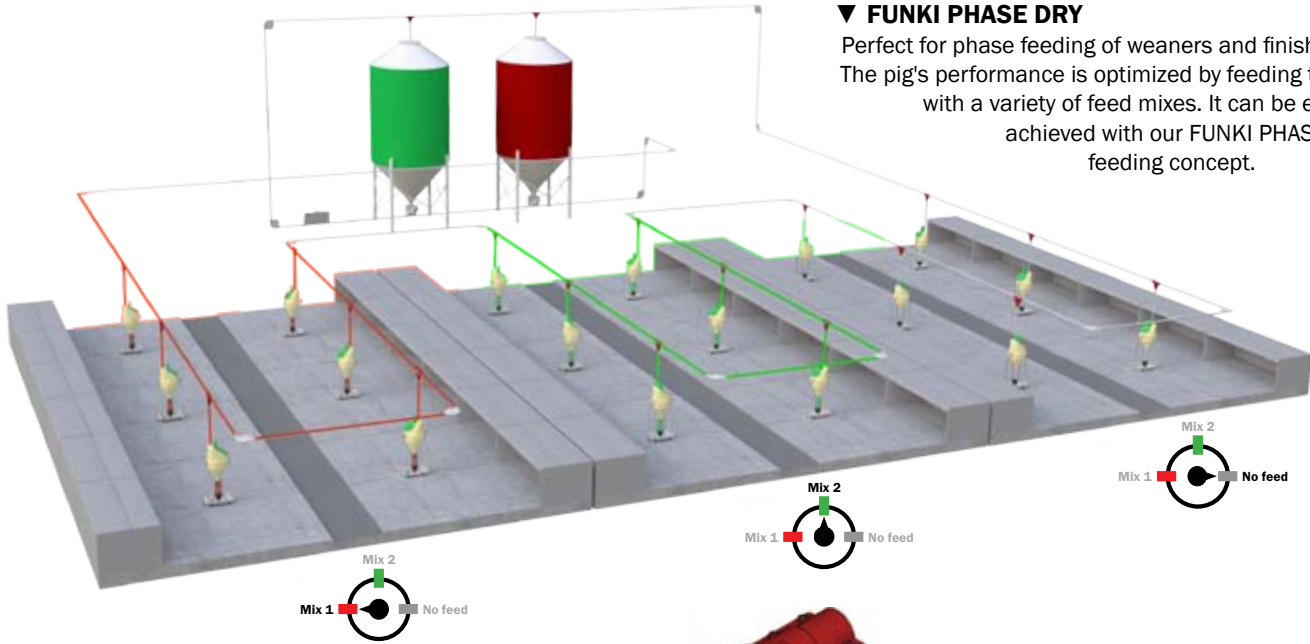

### ▼ FUNKI PHASE DRY

Perfect for phase feeding of weaners and finishers. The pig's performance is optimized by feeding them with a variety of feed mixes. It can be easily achieved with our FUNKI PHASE DRY feeding concept.

#### ► MASTER VALVE DRY

The FUNKI PHASE DRY system allows you to control which feed mixture the pigs should have. The system is powered by a pneumatic cylinder with air pressure - MASTER VALVE DRY.



- Various feed mixes
- Saving feed costs
- Optimal utilization of feed systems
- Simple and reliable

## ▼ FUNKI DRY SECTION

Phase feeding with automatical change of feed mix at section level

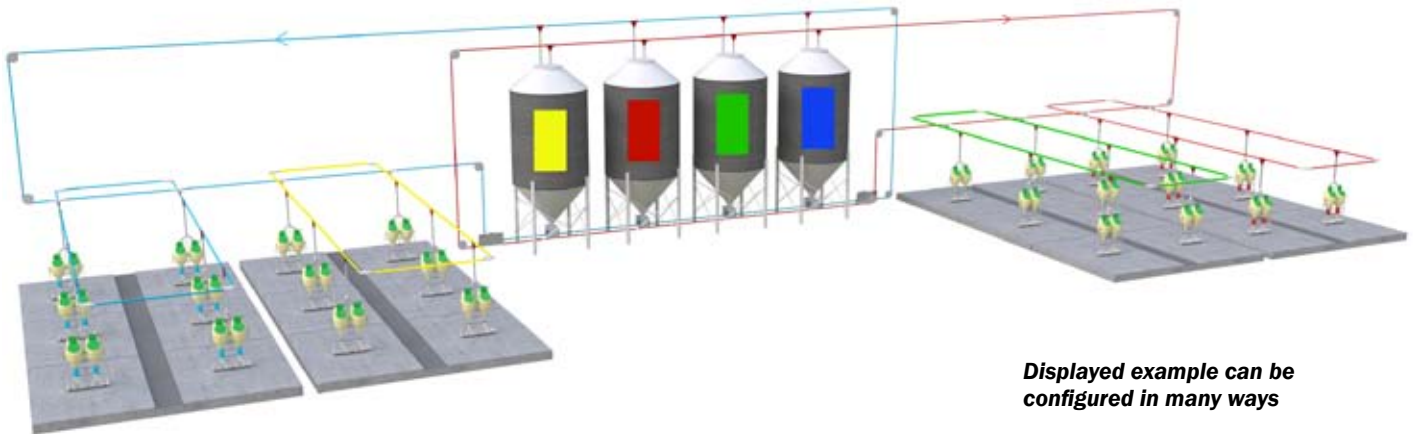

### ▲ FUNKI DRY SECTION

is an easy-to-use, flexible dry feed control system. The system can be adapted to individual needs and wishes.

Funki Dry Section ensures efficient pig production.

Funki Dry Section can be made for both phase feeding and multi-phase feeding. The multi-phase feeding mixes the feed from 2 silos with frequency-controlled speed control and there is a back-up silo for each section.

#### Phase feeding with automatical feed mix change

- PC- and app-operated user interface
- Easy monitoring of daily feed consumption
- Simple and reliable
- Automatic creation of feed curves based on pigs' production results
- Feed curves, mixes, etc., are shown graphically on the screen. Keying errors are thus immediately spotted and corrected
- Storage control with batch registration ensuring complete traceability at all times
- High capacity
- Controls two independent systems simultaneously
- Either direct transport from main unit to section, or with section silos for higher capacity

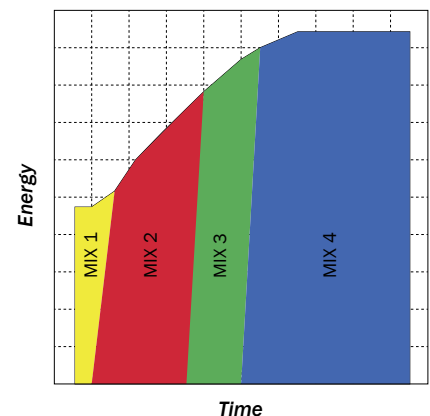

## ▼ FUNKINET DRY SINGLE

Multi-phase feeding at pen level

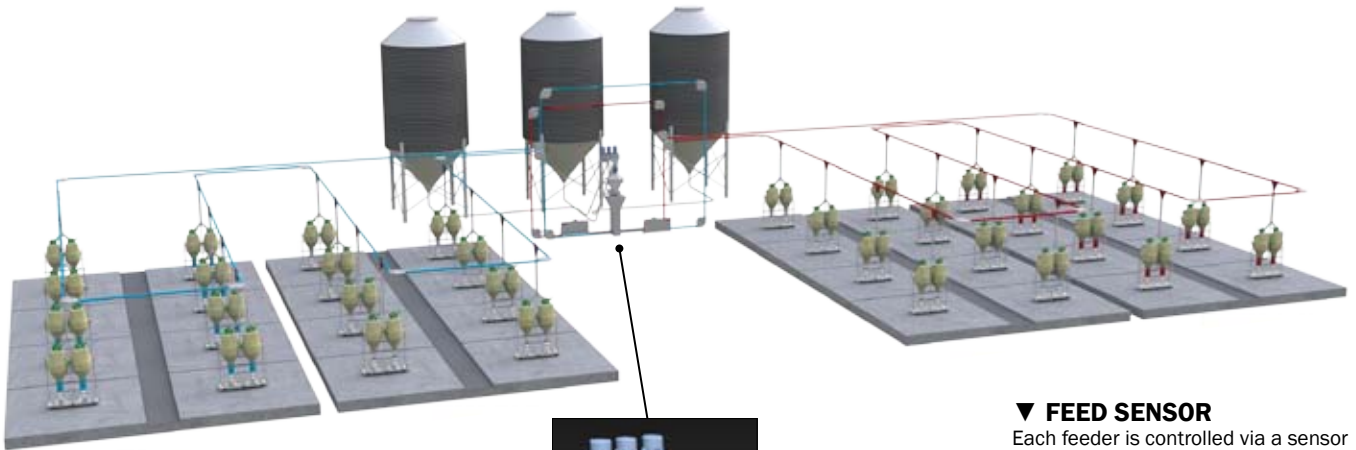

▲ **FUNKINET DRY SINGLE** concept can run with two independent dry feeding system at the same time. This gives the system a unique high capacity

- Accurate feed mixes
- Feed consumption registration at pen level
- Full traceability
- High growth
- Low feed consumption
- Less nitrogen and phosphorus discharge
- Reliable system
- Can be configured to feed sections instead of individual pens

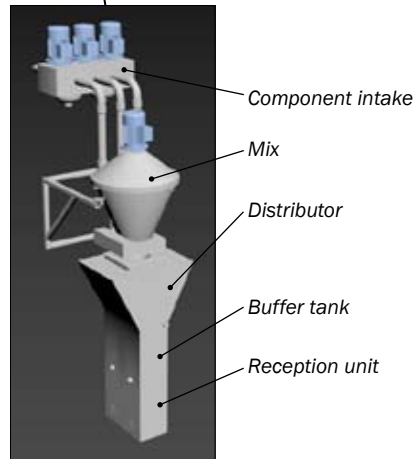

### ▼ FEED SENSOR

Each feeder is controlled via a sensor and can be adjusted according to the amount of feed and how often they are filled.



## ▼ FUNKINET DRY MULTI

Multi-phase feeding with smooth feed change at pen level



- Large capacity
- Smooth feed change
- Higher feed intake
- Lower feed costs
- Less nitrogen and phosphorus discharge
- Reliable system
- Easy to operate

### ▲ FUNKINET DRY MULTI

With Funkinet Dry Multi it is possible to make a smooth feed change between the mixes. The pigs are fed according to a multi phase feeding curve. The reception unit or auger under the silo is frequency controlled so that the smooth feed change occurs by mixing two mixes in the feed line. The system makes one mix complete at a time before switching to the next mix; this ensures a high capacity.

### ▼ OPTIONS FOR SECTION FEEDING



Water measurement



Light control



Silo consumption



Feed control



# VD100 FLOOR FEEDER

## Efficient floor feeding for all age groups

### EASY AND EFFICIENT FEEDING OF SOWS

**VD100 feeder** is specially designed for floor feeding of gestating sows, but can be used for all age groups. It is a simple and effective feeding method. We recommend group size of min. 12-15 sows per pen, but the feeder can also be used for larger flocks of up to 50 sows per pen. It is recommended, that pigs are divided into 3 teams incl. gilts, and by applying immediately after mating in minimum 4 teams. Sorting of the sows is made according to condition and age.



### IT IS THAT SIMPLE

The feeder consists of 1 string-operated hopper for widest possible distribution of feed on the ground. The floor feeder must be able to accommodate the entire feed amount when all the sows are at the highest feeding intensity (4 FU per sow per day is equal to 7 liters per sow). The pen equipment on the slatted floor must be closed the first meters starting from the support post.

### ▼ RECOMMENDED MOUNTING DISTANCE

Max. 20 pcs. of VD100 feed dispensers per piano wire 3 mm. Angle of feed spread is approx. 1½ meters, depending on VD100 mounting height.

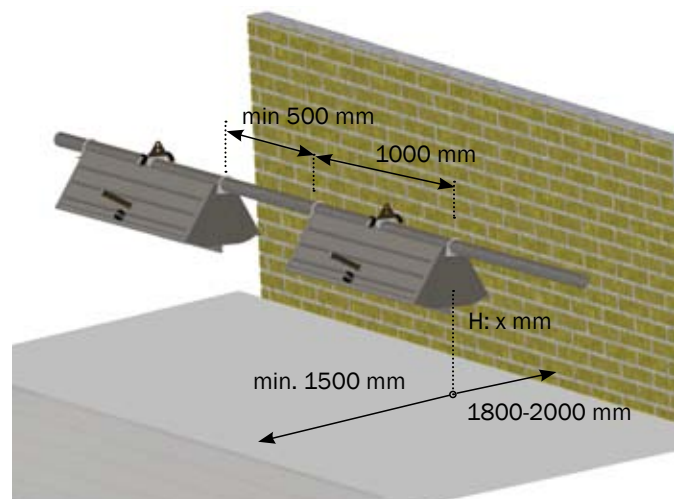

### FACTS

Article no.	0223-240
Width/length ratio	2/3 - 2/4
Volume	40 l
Feeding space	1,3 m <sup>2</sup> /sow



- Can be used for both nursing sows and weaned pigs
- Pigs stay in the familiar environment up to 30 kg
- After lactation the sow is moved while the pigs stay in the pen until 30kg. This is supported by COMBI-FEEDER which can be adjusted manually
- During lactation, the feed is dosed via a mounted feed dispenser
- When the sow is moved, the pigs are fed ad libitum.
- Lower costs, as pigs use the same feeding system



# COMBI-FEEDER

## Weaning in the farrowing pen

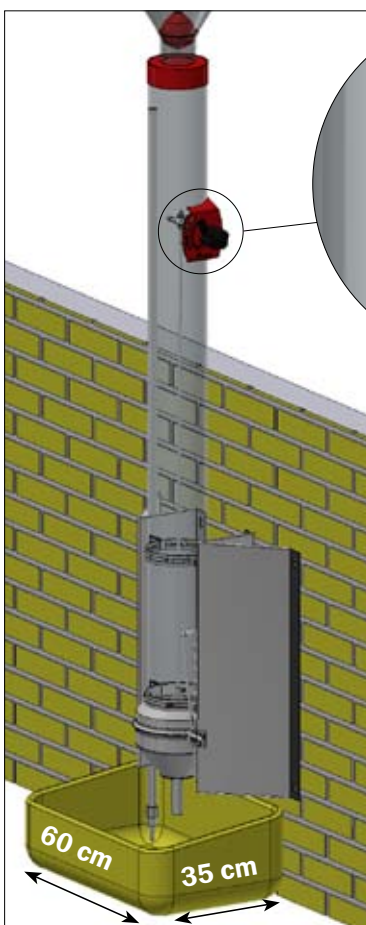

COMBI-feeder complete

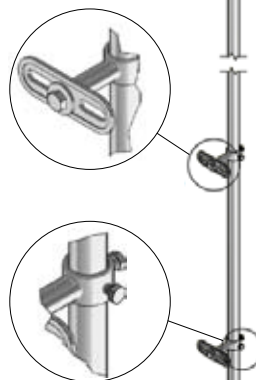

Water pipe for COMBI-feeder



▲ Feeder with pendulum for feeding of the weaned pigs



▲ Feeder without pendulum for feeding of sows

- 50 g higher weight gain for piglets
- Lower costs, as pigs use the same feeding system
- Less diarrhea
- No additional zink in the feed mix
- Save a wash as the weaners stay in the farrowing pen

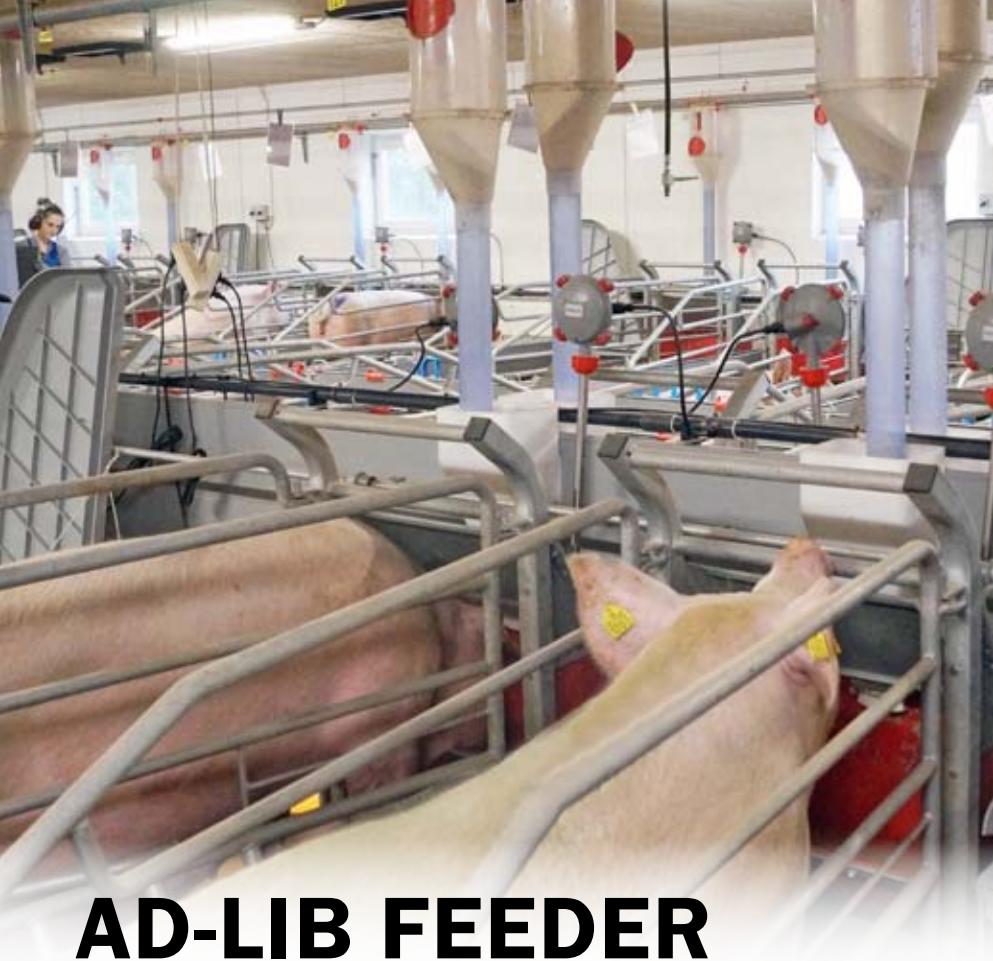

- Ad libitum feeder for lactating sows
- Sow can decide for herself how much she would like to consume from day 1 to weaning.
- Sow can mix feed and water without bridging
- Volume 7 l
- Higher feed intake
- Higher water intake and milk yield
- Higher weight at weaning
- More live born piglets in the next litter

# AD-LIB FEEDER

Almost two more piglets per litter

## PERFORMANCE PER LITTER

A recently completed two-year trial by the University of Guelph (USA) showed a 1.7 piglets per litter increase in subsequent litters for lactating sows using free choice feeders versus other lactating sow feeding methods. The research showed that there are significant benefits to having feed and water in one feeder.

	Lactation			P-value
	Conventional <sup>1</sup>	Semi Ad Lib <sup>2</sup>	Ad Lib <sup>3</sup> (ACO FUNKI)	
<b>Litter size at birth</b>	12,6 a	12,8 ab	14,3 b	0,0455

based on the research from the University of Guelph Ridgetown Campus, USA, 2014.

- <sup>1</sup> "Conventional" was feeding as much as the sow wishes (full feed) from day 3 onward.
- <sup>2</sup> "Semi Ad lib" was such that the amount is slowly ramped up to ad libitum over 13 days.
- <sup>3</sup> "Ad lib" feeding method was self-feeders where the sow could decide for herself how much she would like to consume from day 1 to weaning.



### ◀ SETTINGS

With Ad-lib feeder, the feed dosing can be adjusted according to one of three levels.

- For phase feeding of sows
- Various feed mixes
- Saving on feed costs
- More live-born piglets
- Optimum use of feed system
- User-friendly controller
- Simple and reliable
- Lock for release if the sow has not eaten up
- 6 and 8 l feed dispenser
- Easy adjustment of feed volume
- Can be adjusted with feed in the feed box



# PHASE FEEDING OF SOWS

## FUNKI PHASE SOW and MASTER VALVE SOW

**FUNKI PHASE SOW** is a feed dosing system with integrated feed valve - **MASTER VALVE SOW** - for phase feeding of sows. The system supports the possibility to feed with two mixtures during lactation, which leads to a fewer still-born piglets.

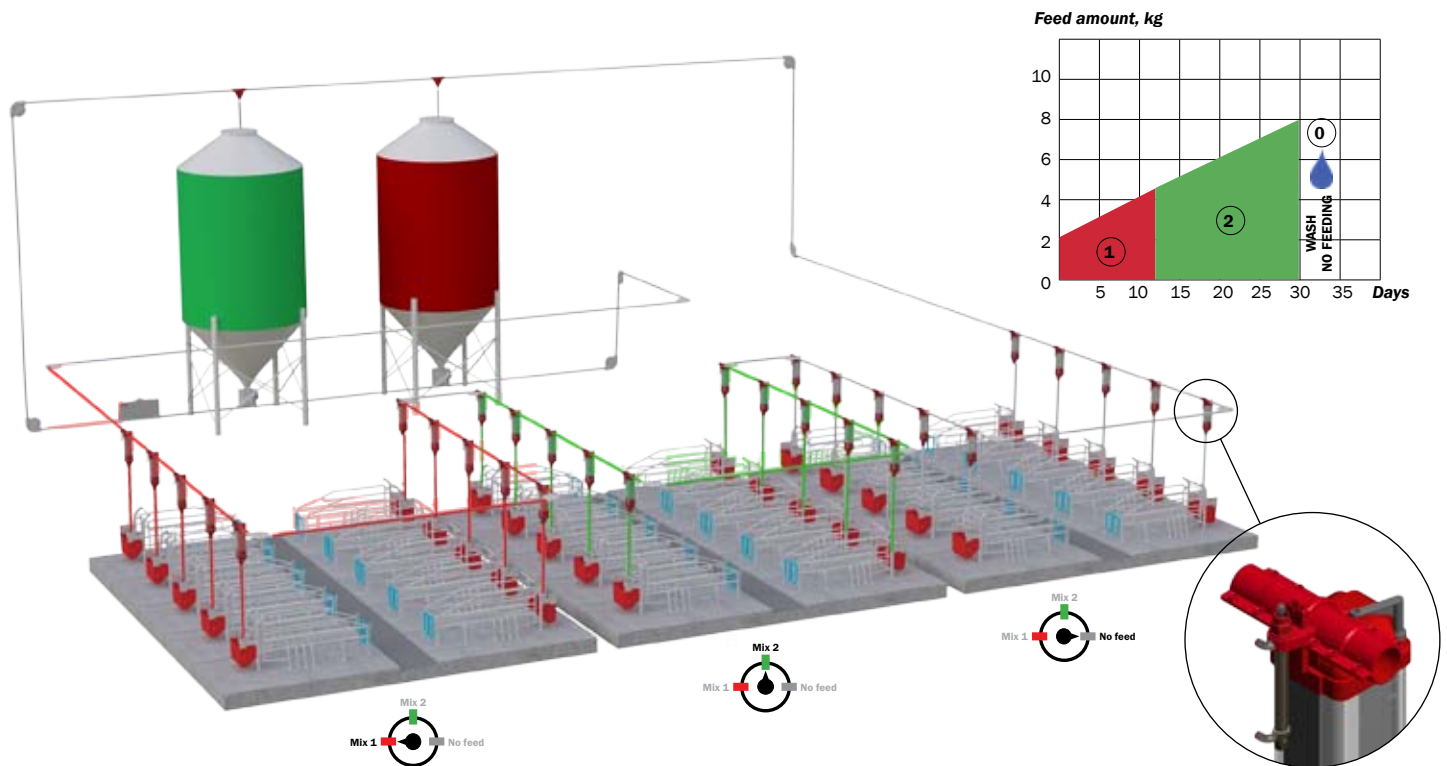

### EFFECT OF TWO MIXTURES DURING LACTATION PERIOD

Group	Control	Experiment	P-value*
Animals team	32	32	-
Amount of sows	298	322	-
Piglets born, in total per litter	18,4	18,1	0,377
<b>Piglets born dead, % of the piglets born in total</b>	<b>8,7</b>	<b>6,6</b>	<b>&lt;0,0001</b>
Piglets mortality during the nursing period, %	14,6	13,7	0,213
Total mortality, among piglets, %	22,3	19,9	0,004

**Control** - results when using one feed mix during the entire nursing period.

**Experiment** - results when using fiber-rich mix during the first 7 days of nursing period, and then a regular nursing feed mix.

\* The specified P-values indicate, whether the differences were statistically secure. Only at  $P < 0,05$  the effect was considered statistically secure.

Source: Bruun et al., 2015.

**Capacity  
6/8/10 L**



- Exact dosage of feed amount
- Can handle two types of feed mixes at a time
- Adjustable feed amount down to 0.2 kg
- Detachable bottom hopper
- No bridging
- Easy to clean
- Simple design
- Competitive price
- The bottom hopper can be mounted in 4 positions

# VD2 + VD22 FEED DISPENSERS

2 feed mixes for sows

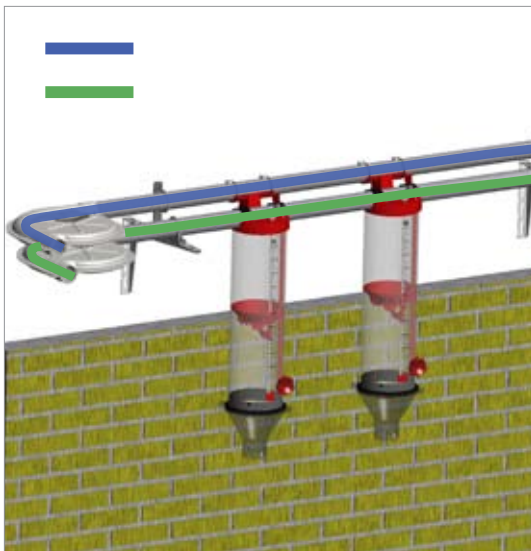

**VD2 FEED DISPENSER**



**VD22 FEED DISPENSER**



**75 mm outlet**

- Ø 60 - 6 L
- Ø 60 - 8 L
- Ø 60 - 10 L

Can be used on Ø38, Ø50 or Ø55 feed pipe with adapter

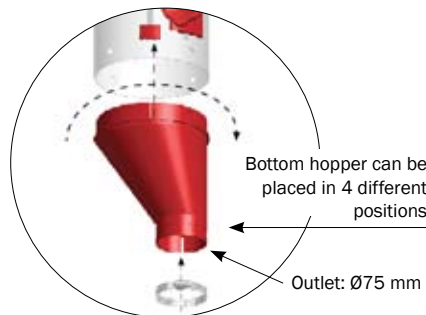
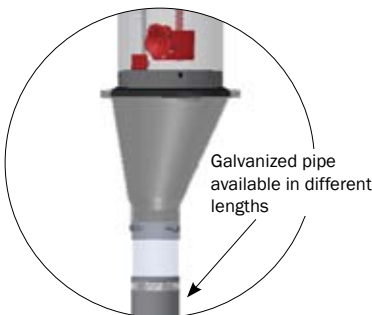

**◀ BOTTOM HOPPER**

Made of plastic. Central or asymmetrical design.



**▲ TURN BUCKLE FOR EASY ADJUSTMENT**

Precise and easy dosage of feed.



- Easy to clean, good hygiene
- Minimum maintenance
- Made in transparent plastic - exact overview of the feed amount
- Easy allocation of nutritional supplements and medication
- Suitable for flour or pellet feed
- Easy and efficient cleaning of feed downpipe
- Ventilation of the feed pipe via the funnel - minimizes moisture formation



# VD5 + VD6 FEED DISPENSERS

Many combinations. Simple design



## ◀ VD5 FEED DISPENSER 75 mm outlet

- Ø 38 - 8 L
- Ø 50 - 8 L
- Ø 55 - 8 L
- Ø 60 - 8 L
- Ø 75 - 8 L

- Asymmetrical hopper prevents bridging
- Large lid and removable funnel for easy cleaning
- The volume is easily adjusted with a slide pushed up / down
- Can be adjusted with feed in the feed dispenser
- The ball ensures that the feed is released at a controlled rate
- Ability to reduce feed inlet down to 0.90 liters

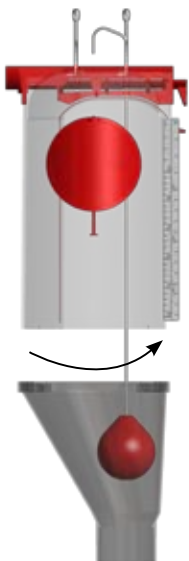

### ▲ DETACHABLE HOPPER

Central or asymmetrical design.



### ▲ LARGE CLEANING OPENING



### ▲ REDUCTION

With reduction inlet and/or hopper.



## ◀ VD6 FEED DISPENSER 75 mm outlet

- Ø 60 - 6 L with flap
- Ø 60 - 8 L with flap

- No bridging
- Two lids for inspection (top and bottom)
- Can be adjusted with feed in the feed dispenser
- Locking function allows to omit feeding from a single place
- The bottom hopper can be set in 4 positions



### ▲ LOCK-FUNCTION



### ▶ TWO INSPECTION LIDS



# 3IN1 NX AND FUNKIMAT

For weaners and finishers



## 3IN1 NX Feeder

3IN1 NX has a patented **3IN1 feeding principle**: dry feed, fresh water and soaked feed. Perfect for both flour and pellet feed.

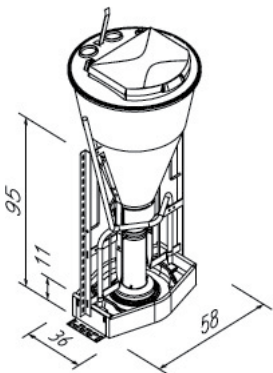

**3IN1 NX MINI 60W**  
30-40 pigs per automat

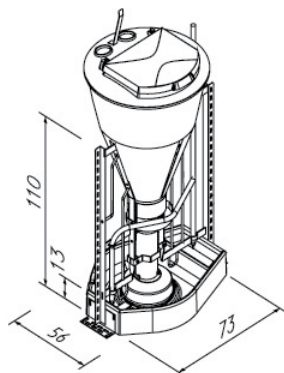

**3IN1 NX MAXI 70W**  
50-60 pigs per automat

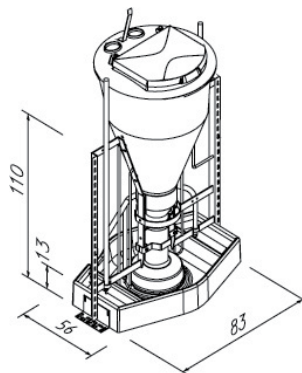

**3IN1 NX MAXI 80W**  
60-75 pigs per automat

◀ **3IN1 NX** is available in different dimensions for weaners and finishers, with polymer trough. Delivered assembled or unassembled.



## FACTS

	FUNKIMAT	3IN1 NX
Volume, hopper	100 liter	120 liter
Frame	40x3 mm, flat frame	Angle frame
Trough	SS / polymer	Polymer

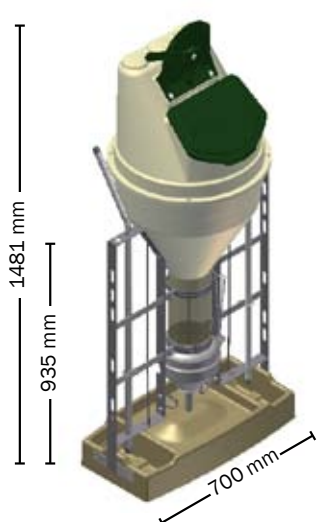

**FUNKIMAT SINGLE**  
30-50 pigs per automat

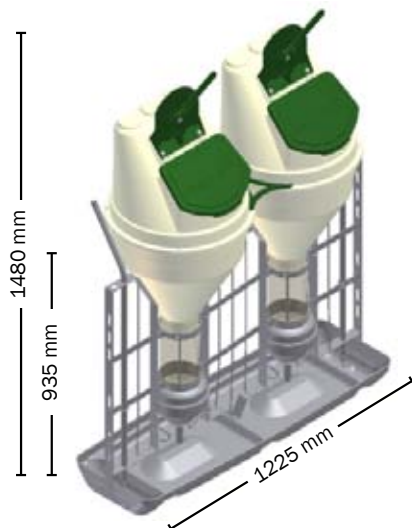

**FUNKIMAT DOUBLE**  
40-80 pigs per automat

## FUNKIMAT FEEDER

FUNKIMAT is made solely of stainless materials to ensure durability. The FUNKIMAT is available in all models with pen sides of 1 m height, suitable for installation in pen partitions. Placing the feeder independently in the pen is also an option, when adding two posts (accessories). Note that pen equipment towards the feeder must be ended with posts fixed to the floor.

The feed containers is designed to ensure optimum utilization of the volume and allows filling from low height. The container is waterproof for sprinkling and prepared for automatic filling from up to three feed circuits.

◀ **FUNKIMAT**  
single or double available for weaners and finishers, with trough made of stainless steel or polymer concrete. Delivered assembled or unassembled.



## Stainless steel trough - for FUNKIMAT DOUBLE

FUNKIMAT - WEANERS	
FACTS	
Weaners	5-30 kg
Trough height	100 mm
Pigs per trough	50-80

FUNKIMAT - FINISHERS	
FACTS	
Finishers	30-120 kg
Trough height	130 mm
Pigs per trough	40-70





### TUBE-O-MAT® HOPPER

- The hopper is shaped in a way to optimize the volume usage
- The hopper has almost vertical sides to prevent bridging
- Lid with three feed inlets for correct feed supply
- Transparent, easy to open lid, for simple manual filling and inspection
- Feed amount in TUBE-O-MAT can be controlled from the passage

### TUBE-O-MAT® CLASSIC

- Specially developed for finishers
- Extra strengthened feed outlet that can withstand the large pigs' constant activation
- The trough is designed to prevent feed from getting wet and clumpy and from getting into the water bowls
- All our feeders are available with flat frame or angle frame

# TUBE-O-MAT®

Reliable feed intake from day 1



TUBE-O-MAT® VI+ trough and dosage part



TUBE-O-MAT® CLASSIC trough and dosage part

### TUBE-O-MAT® VI+

#### Reliable feed intake from day 1

The shielding is made of transparent plastic, which allows a maximum overview and easy control of the hygiene. It is easily opened without use of any tools. The dosing unit consists of very few parts which ensure a high level of hygiene and easy cleaning.

The activating part in stainless grille construction can easily be activated by the pigs and they quickly learn how to operate it. It ensures a reliable feed intake from day one.

#### Calm animals

The large opening and the integrated agitator ensure a constant feed flow and prevent bridging. The emergency closing system prevents feed waste.

#### Safe investment

The activating part on Vi+ models is made of stainless steel and is designed for both piglets and finishers. Simple and very strong.

#### Maximum use

All TUBE-O-MAT® feeders have hoppers and lids, developed with focus on maximum user-friendliness, easy cleaning, overview and space utilization. The choice of material - plastic and stainless steel - ensures long durability.

The feeding principle considers the natural rooting behavior, as the pigs have to activate the feeder to get feed. Consequently, the trough is cleaned and free of feed residues. Hygiene and health are 1st class.

TUBE-O-MAT® trough has double drinking bowls allowing the pigs to choose water, dry feed or soaked feed.

- High feed intake gives high growth and less weight variations
- Good feed conversion reduces lost of nutrients
- Easy cleaning ensures low working time consumption



**TUBE-O-MAT**



**TUBE-O-MAT JUMBO**

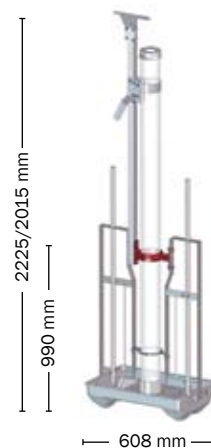

**TUBE-O-MAT TUBE**

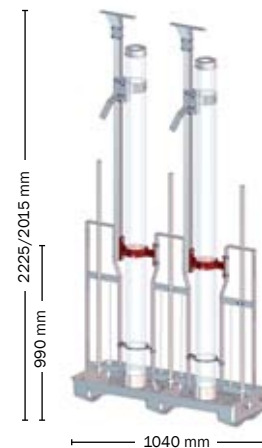

**TUBE-O-MAT TUBE JUMBO**

TYPE OVERVIEW		
Description	Weaners	Finishers
TUBE-O-MAT VI+	x	x
TUBE-O-MAT VI+ JUMBO	x	x
TUBE-O-MAT CLASSIC	(x)	x
TUBE-O-MAT CLASSIC JUMBO	(x)	x
TUBE-O-MAT TUBE	-	x
TUBE-O-MAT TUBE JUMBO	-	x

FACTS		
Volume	CLASSIC	JUMBO
Hopper	83 liter / approx. 58 kg	160 liter / approx. 112 kg
Capacity per trough	CLASSIC	JUMBO
Weaners up to 30 kg	30-50 pigs	
Wean-to-Finish 7-120 kg	30-50 pigs	50-70 pigs
Finishers	30-50 pigs	50-70 pigs
Frame		
TUBE-O-MAT is delivered with 4 mm frame made of stainless steel		
Water supply		
3/8" stainless steel pipe with external thread		
Adjustable press nipple made of stainless steel		



▼ TROUGH SS - FOR TUBE-O-MAT

CLASSIC - WEAN-TO-FINISH	
FACTS	
WEAN-TO-FINISH	7-120 kg
Trough height	110 mm
Pigs per trough	30-50

CLASSIC + TUBE - FINISHERS	
FACTS	
Finishers	18-120 kg
Trough height	150 mm
Pigs per trough	30-50

CLASSIC + TUBE JUMBO - WEAN-TO-FINISH	
FACTS	
WEAN-TO-FINISH	7-120 kg
Trough height	110 mm
Pigs per trough	50-70

CLASSIC + TUBE JUMBO - FINISHERS	
FACTS	
Finishers	18-120 kg
Trough height	150 mm
Pigs per trough	50-70

# FEEDERS

Stainless steel and plastic

## ► CCM FEEDER

is a special feeder which is especially suitable for feeding of sows in group pens. CCM feeder is used for ad libitum feeding with raw, fibrous feed.

Mini: 18090  
Maxi: 18746



▼ **UNIFEEDER** - intelligent feed allocation at the farrowing stable. UNIFEEDER is easy to operate. The feed curve is default preset to a litter size of 14 pigs. On the control panel, the feeding can be adjusted to a larger or smaller litter size.

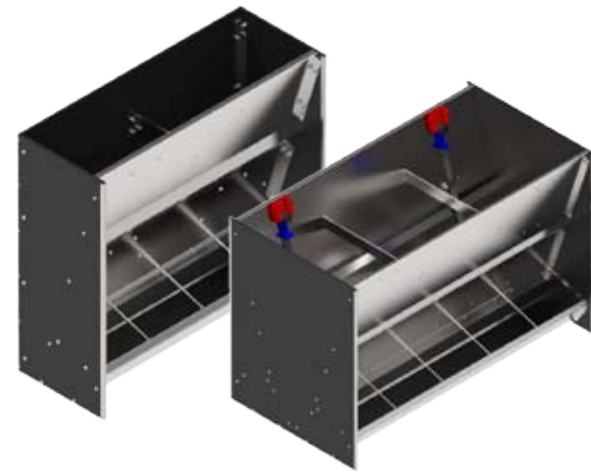

## ◀ BOX FEEDER

Feeder made of stainless steel and plastic (PP). Available in many different sizes and types for weaners and finishers.

- Feed for 20-100 pigs per feeder
- Easy access to feed
- No sharp edges
- Easy to clean
- Minimum feed waste
- Adjust the feed amount with a screw on the front plate
- 2-6 eating places for 20-120 weaners
- 2-5 eating places for 20-100 finishers

## ▼ ► WET/DRY FEEDER

Wet/dry feeders for Wean to Finish are available with features and options designed to meet the specifications and expectations of today's modern pork production systems. Manufactured using corrosion resistant 304 stainless steel and welded construction, these feeders are engineered for durability, ease of cleaning, simple management and superior feed conversion performance.



The trough is equipped with dividers to separate eating places.



The adjustment system requires only two adjusters per feeder providing quick, accurate and consistent control of feed gate settings.



Water comes out of the press valves in the trough.

# ACCESSORIES

Efficient and hygienic feed outlet for feeders



**SINGLE DOWNPIPE**



**Y-MODEL**



**TELESCOP**

## Feed outlet

Feed outlet has a number of unique functional advantages ensuring effectivity and good hygiene.

## Large capacity

The lower part of the outlet is oval and shaped in a way which makes it possible to drill more holes or cut a slot in the feed tube. This ensures a quick and effective draining of feed.

## Always dry feed

The design of the feed outlet counteracts penetration of water and moisture.

## Reliable slide

The slide fits tightly to the feed pipe, which prevents feed from accumulating which otherwise affect the function of the slide. The slide can easily be "remote controlled" by for example a broom stick, if it cannot be reached from the feeding passage.



## ◀ OUTLET SIZE:

38 / 60 mm

## ▶ OUTLET SIZE:

38 / 50 / 60 / 76 mm



## ▼ FLOOR PLATES FOR FEEDERS

Protects the floor and reduces feed waste

### Floor plates for feeders

We recommend using a plate under the feeders. This helps to protect the floor from corrosion from the feed while avoiding too much of the feed spilled down through the slots in the floor. The plates have a non-slip structure in the surface.



**SINGLE FUNKIMAT AND 3IN1 ROTO**  
10 x 670 x 1200 mm. (Article no.: 0227-559)

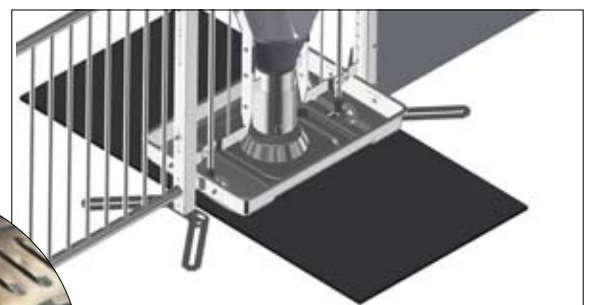

**SINGLE TUBE-O-MAT**  
10 x 608 x 1200 mm. (Article no.: 89014)



**DOUBLE FUNKIMAT AND 3IN1 ROTO**  
10 x 1200 x 1200 mm. (Article no.: 0227-558)

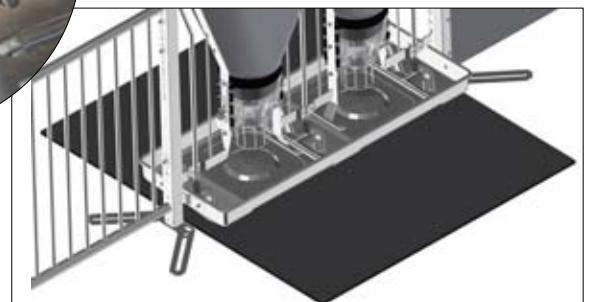

**DOUBLE TUBE-O-MAT**  
10 x 1040 x 1200 mm. (Article no.: 89016)

# EQUIPMENT FOR SOWS

We offer mating and gestation stalls. With our penning equipment for sows you are sure that both functionality and quality meet your requirements



**FUNKI F207**



**FREE ACCESS STALL**



**WELSAFE**



# FREE ACCESS STALL

Combined mating and gestation unit

- Open stall with plenty of space for the sows
- Minimum maintenance
- Top hinged rear gate - ensures easy access to sows
- Optimum space utilization
- Suitable as a mating stall
- Easy inspection, scanning and treatment of the animals gives better production and less time consuming
- Can be adapted to all floor types with multi-adjustable foot bracket



## FACTS

Stall length	2340/2100 mm
Lying length	2000/2100 mm (w. front grille extension)
Height	1033 mm
Width	600/650/700 mm
Posts	40 x 40 x 4 mm
Rear support	25 mm solid cast iron
Horizontal pipe	33,7 x 2,65 mm
Front gate/rear gate	Side hinged/ top hinged
Locking system	Integrated into the stall side
Quality type	Hot galvanized
Water supply	1" galvanized or stainless steel pipes
Water inlet	½" SS pipe, SS nipple. 1 per 2 boxes

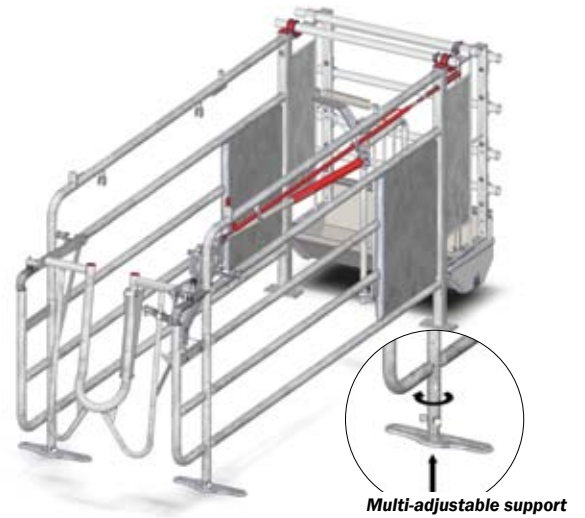

## ▲ GOOD OVERVIEW

With a free access stall in the gestation unit it is easy for the operator to get an overview and very easy to daily monitor the sows.

### Did you know that...

...If you have 400 sows in the gestation unit, you can save 1 second of working time per sow, per day, that is an entire work week in a year.

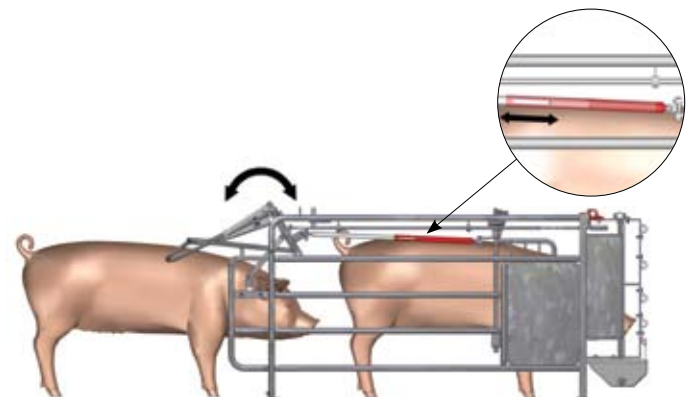
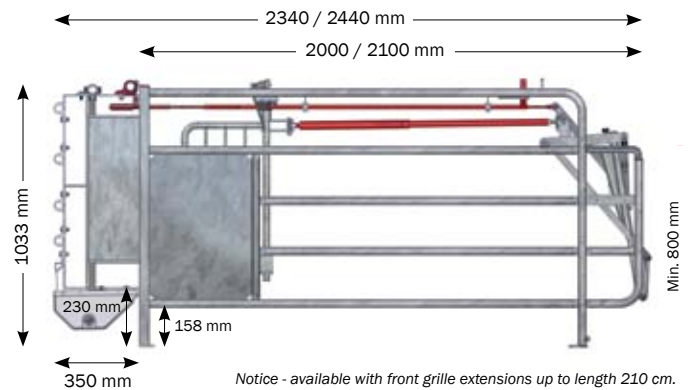

# LD-STALL

Traditional mating stall



- Easy access and good space ratio for sow as well as staff
- Ensures optimum stimulation and time of service
- The side covered trough gives an undisturbed eating situation and thereby a low stress level
- The open front grille/front gate provides a superior boar contact and ensures clear heat symptoms
- Rounded equipment parts and focus on finish to minimize the risk of injuries
- Multi-adjustable foot bracket

## FACTS

Stall length	2680/2780 mm
Lying length	1900/2000 mm (w. front grille extension)
Height	2000 mm
Width	650 mm
Posts	40 x 40 x 4 mm
Upper pipes	33,7 x 2,65 mm
Lower pipes	33,7 x 2,65 mm
Bars	14 mm solid round iron
Front/reargate	Side hinged
Locking system	2 meter height
Quality	Hot galvanized
Water supply	2 meter height: 1" galvanized or stainless steel
Water inlet	½" SS pipe, SS nipple. 1 per 2 boxes



Multi-adjustable support

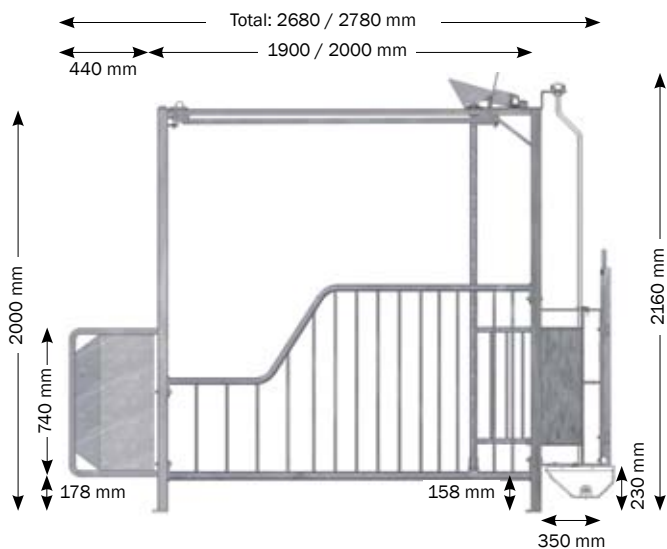

Notice - available with front bars extensions up to length 200 cm.



## ▲ OPTIMAL MATING STALL

LD-stall is a mating stall, that has an easy operating gate function and gives the sows a free choice. They can choose to stay in the stall or in the resting area with the deep straw bedding. The sows are able to sort out the hierarchy in the group before mating, which gives the embryo the best conditions after fertilisation. Easy access through the rear gate, one-hand operated front gate and 2 meters height give the best working environment.

Subject to changes in materials and design is reserved.

# MULTIBOX COMFORT

For mating and gestation with loose sows

- Easy access and good space for both sows as well as staff ensures optimum overview and maximum comfort for sows
- Top hinged front and rear gate for easy access to sows
- Suitable as a mating box
- Ensures the sows against fights and injuries
- No training of sows is required



## FACTS

Box length	2400/2550 mm
Lying length	1920/2020 mm (w. front grille extension)
Height	1000 mm
Width	500/600/650 mm
Posts	40 x 40 x 4 mm + 50 x 50 x 4 mm
Horizontal pipes	33,7 x 2,65 mm
Front gate/rear gate	Top hinged
Material	Hot galvanized
Water supply	2 meter height: 1" galvanized or stainless pipe
Water inlet	½" SS pipe, SS nipple. 1 per 2 boxes

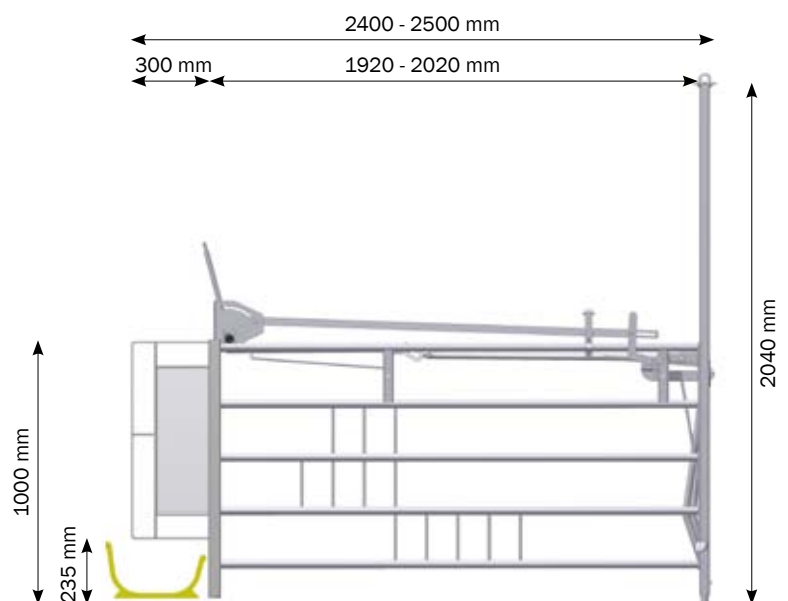
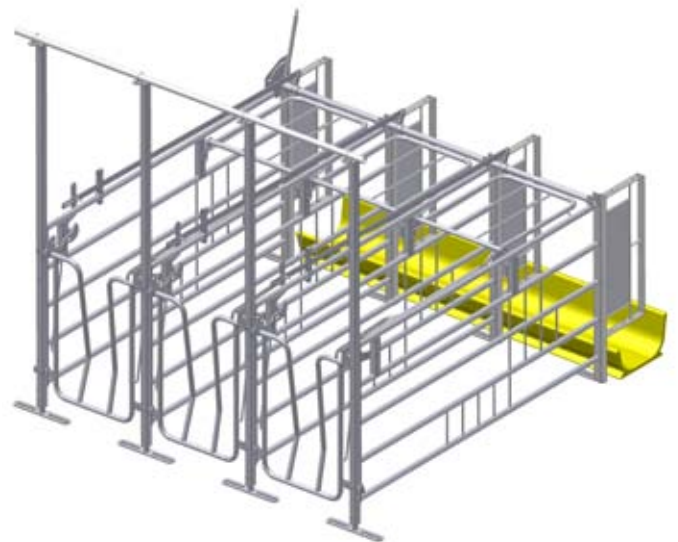

# JUMB-O-FINE BOX

For weaning and gestating sows



**JUMB-O-FINE** is a box for weaning and gestating sows. Free access to the sow due to the unique Duo rear gate. There are no upper pipes which means free access to the sow throughout the length of the box.

Simple locking system without loose pins. Extra strong box construction. Multi-adjustable support.

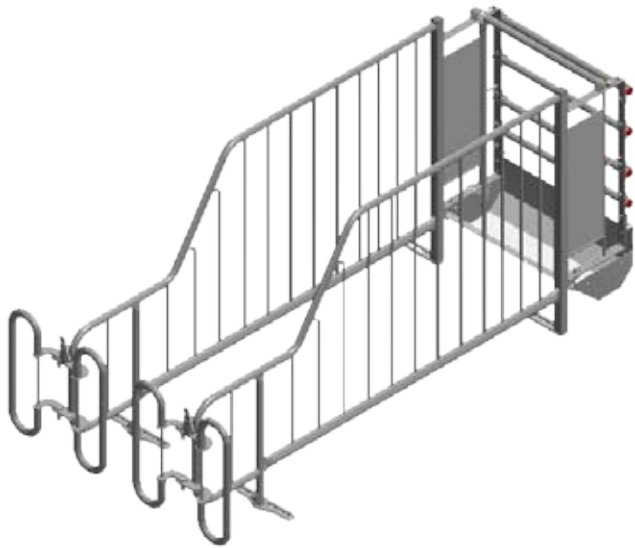

## FACTS

Box length	2330 - 2470 mm
Lying length	1900 / 2000 mm (w. front grille extension)
Height	1100 mm
Width	Variable 550 - 750 mm
Posts	40 x 40 x 3 mm
Upper pipe	33,7 x 2,65 mm
Lower pipe	42,5 x 2,65 mm
Bars	14 mm solid round iron / 12 mm in the back
Rear gate	Duo gate box width 620-700 mm / 710-780 mm
Quality	Hot galvanized
Water supply	High piping PVC / low piping SS
Water inlet	½" SS pipe, SS nipple. 1 per 2 boxes

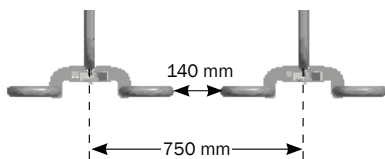

Wide rear gate, adjustable 710-780 mm

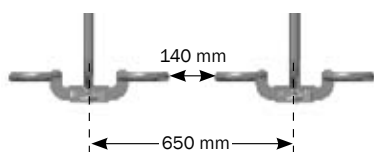

Narrow rear gate, adjustable 650-700 mm

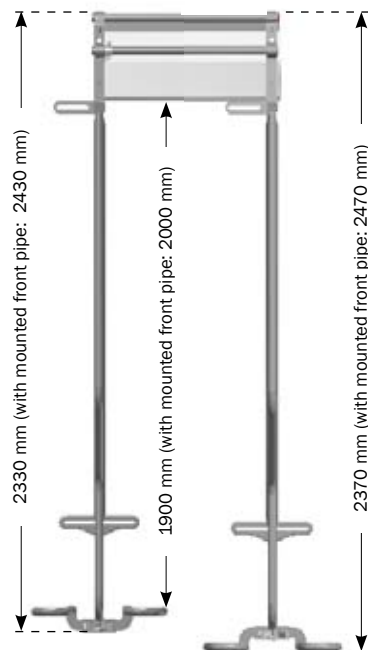

Short rear gate

Long rear gate

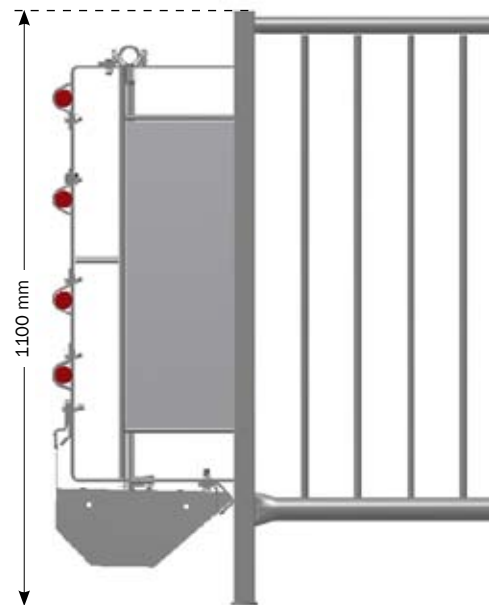

# BOAR DOOR WITH DISTANCE CONTROLLED HANDLE

For easier insemination process

This special boar door is designed in order to make the insemination process easier. Thanks to the long handle, the door can be opened from the distance, without entering the mating box. To ensure long durability, the door can only be opened in one direction, as the lock stop is mounted (optional right or left). It makes it easier to slam the door, when the boar has passed.

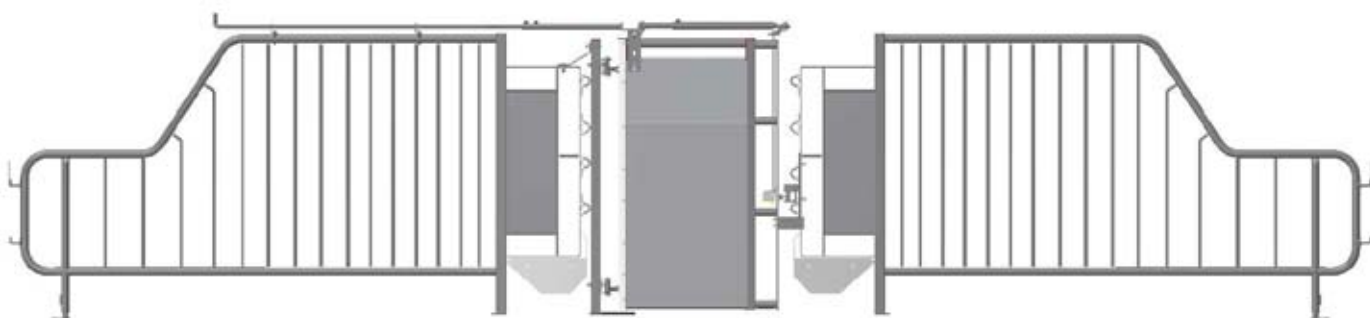
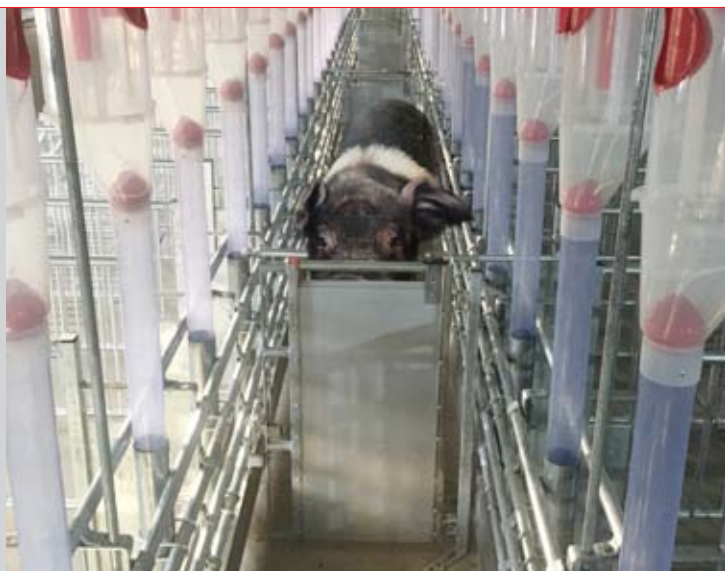

## BOAR DOOR

### Description

Assembled boar gate H110 for Jumb-O-Fine, Free Access, Multi Comfort and LD-box

Set for boar gate Jumb-O-Fine and LD-box with front pipe, aisle width 70-105 cm

Mounting kit for concrete floor with 2 bolts

Mounting kit for slats with 2 anchors and bolts

**Boar door adjusted on site**



### ▲ DISTANCE CONTROLLED HANDLE

It is easy to open the gate without entering the box.

# BLOCKING GATES AND HINGE BRACKETS

CLEAN-O-FLEX®



- Easy to learn for the sow
- Strong and stable
- Simple and reliable
- Easy to assemble
- Work-friendly
- Timesaving
- Various sizes

## Single hinged

Height 75/100 cm

- Easy access with pin lock
- One-hand operated
- Opens and closes at bracketside
- Available in widths up to 250 cm

BARRIER GATES - SINGLE HINGED	
Height (cm)	Width (cm)
75 / 100	Max 120
75 / 100	Max 170
75 / 100	Max 220
75 / 100	30-250



## Double hinged

Height 75/100 cm

- Fastened in both sides
- Opens and closes at both sides
- Can be moved to other positions
- Reversible

BARRIER GATES - DOUBLE HINGED	
Height (cm)	Description
75	Board profile, reversible
100	Board profile, reversible

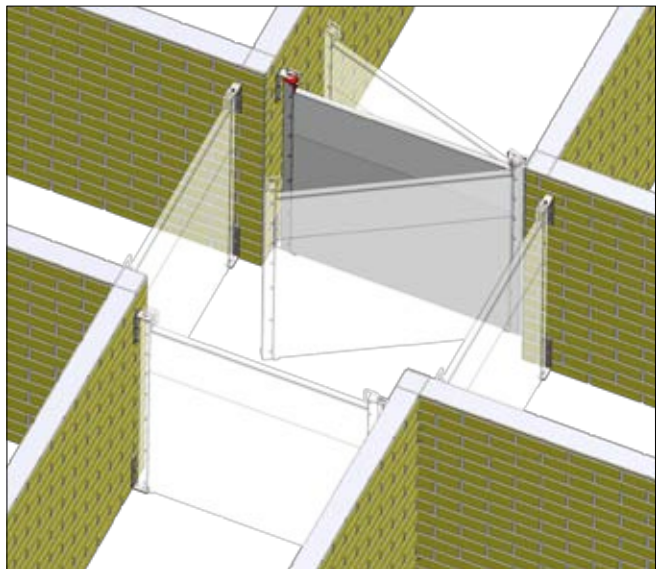

# TROUGHS, FRONT BARS AND FRONT GATES

We have the best solution for you

- Water supply system made of stainless steel as part of our standard solution
- One nipple per two sows creates a secure water supply for your sows.
- High front edge and folded edges on the trough minimize feed waste and ensure better hygiene
- Double rows allow joint front piping
- Front gates can be combined with stainless steel troughs or polymer concrete troughs
- High water piping allows personnel to follow the sows through the front gate
- Our front extension is a unique option for animal welfare - newly established as well as already existing boxes can be extended

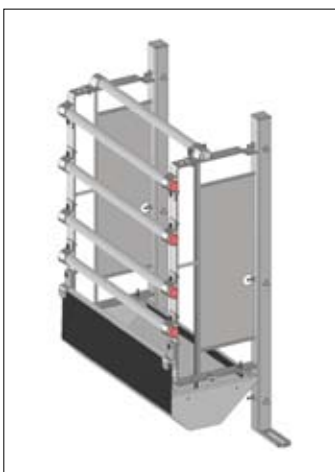

Front pipes + stainless trough

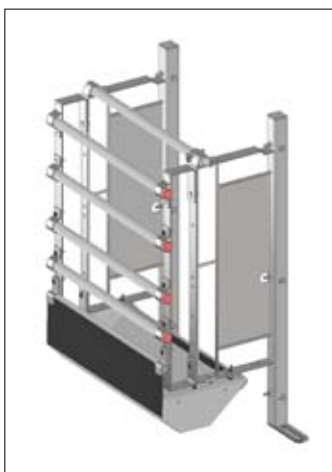

Front pipes + front pipes extension + stainless trough

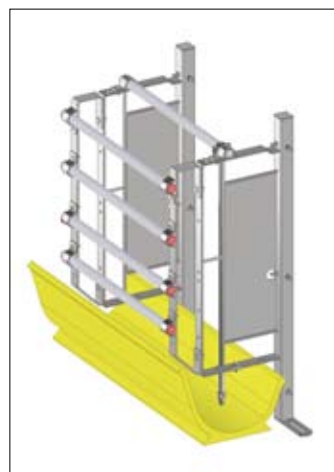

Front pipes + front pipes extension + polymer trough

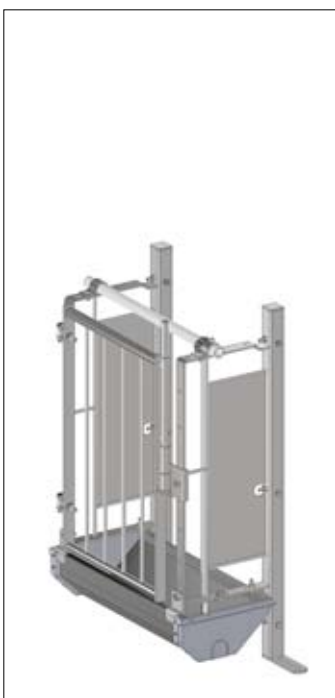

Front gate + stainless trough

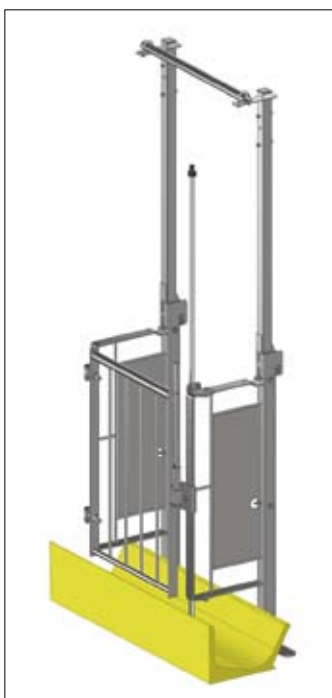

High front gate + polymer trough + high piping

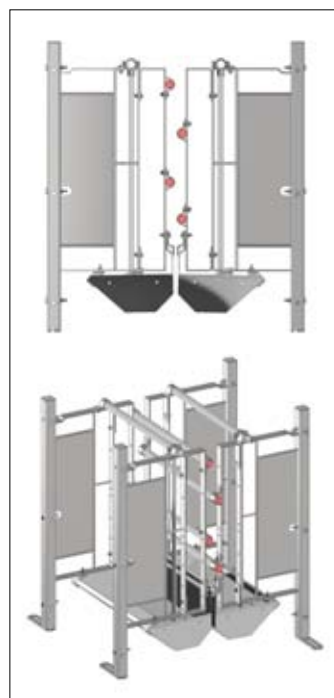

Double trough + double front pipes + stainless trough

# WINCH SYSTEM

A simple and efficient solution with long durability



- When using straw bedding, the winch system is a simple and inexpensive solution to get the straw out of the channels again
- Reduces ammonia and odor emissions
- Minimum maintenance costs
- No limitation on straw length
- Benefits of environmental applications



## ▲ SCRAPER

A particularly simple scraper with few moving parts.

Scraper height: 30 cm

Scraper width: channel width minus 4 cm

Types: 100-150 cm, 150-200 cm and 200-250 cm.

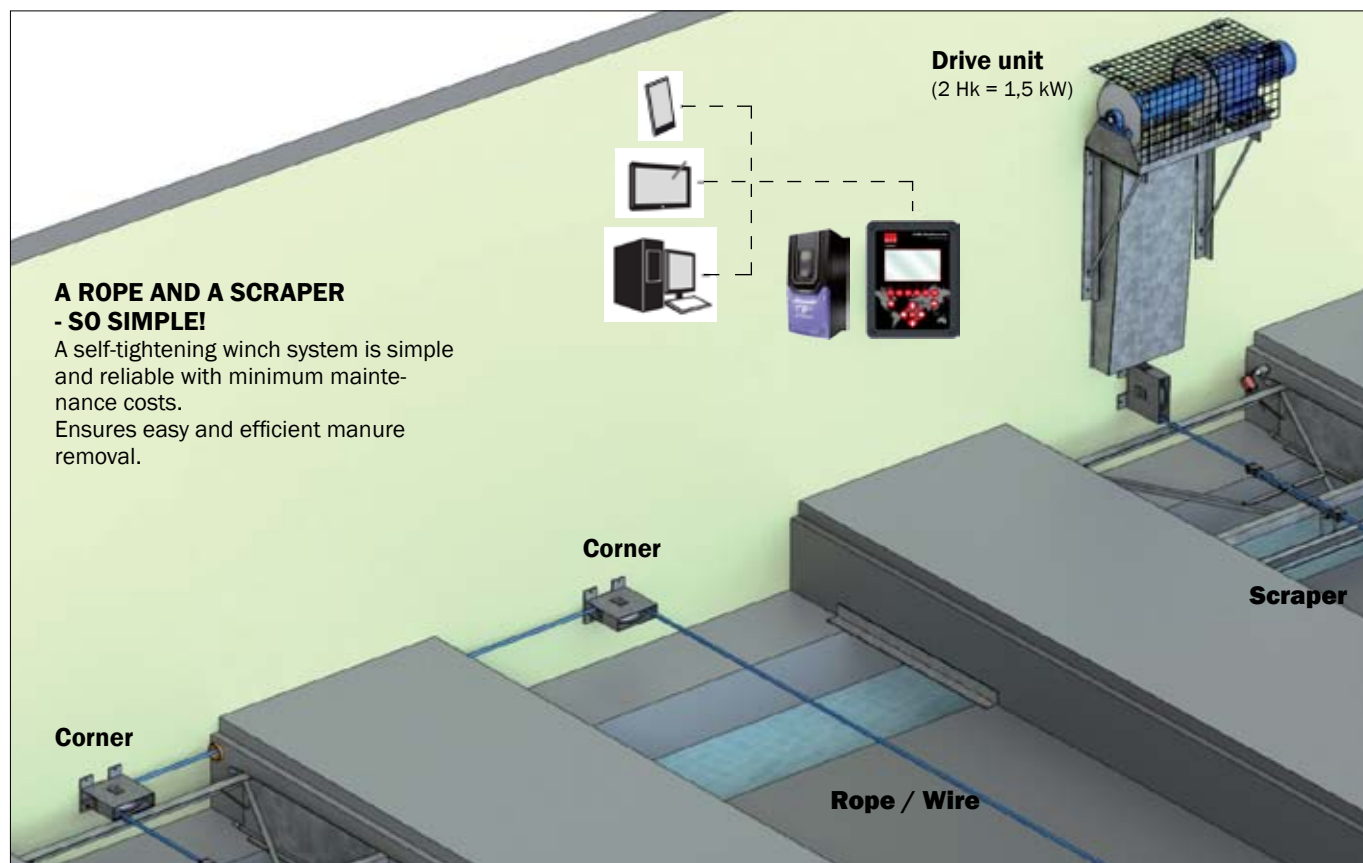
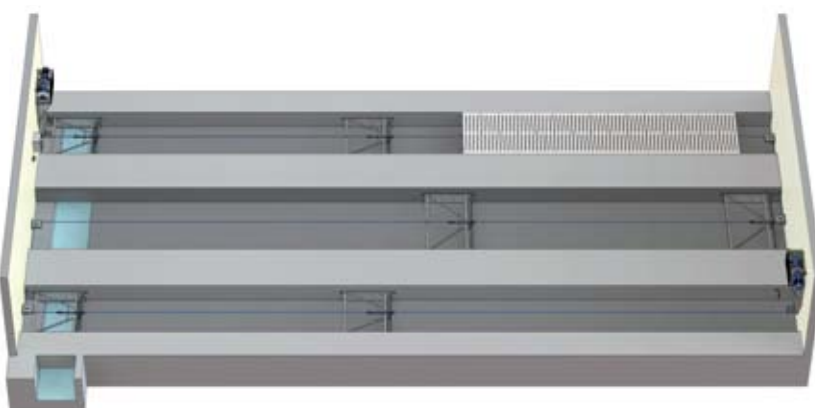

Contact us for more information about winch system.



# ACCESSORIES FOR MATING STALLS

LED-light and automatical stimulation of sows

## ▼ INN-O-LED "PLUG 'N' PLAY"

The right lighting in your stall is important for optimum pig production. The INN-O LED moves the light into the sows' living zone, which gives better light. The INN-O LED is easy and affordable to use in everyday with a smart click fitting. The LED luminaires are series-connected and modular. The installation can be done by the pig farmer with a Plug 'n' Play cable.

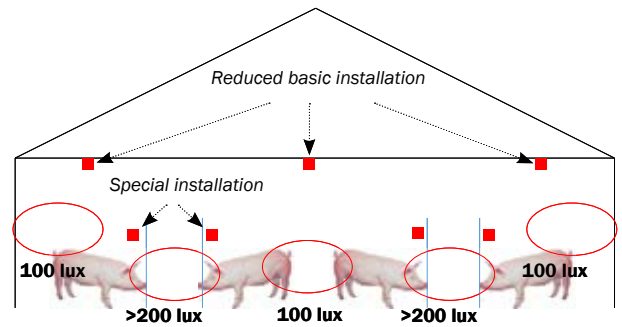

EL-SAVINGS  
60-80%



## IMPORTANCE OF LIGHT

### Gestation unit

- Light has an effect on excretion of estrogen
- 3% higher farrowing percentage
- Avoid autumn crashes

### Farrowing unit

- +0.5 more born piglets per litter
- More light to sows, gives increased milk yield
- Higher weight at weaning after switching to LED

### Piglet nest

- The goal is to attract the piglets into the piglet nest
- The light is yellow (2700 Kelvin) - it is visible to piglets

### Economy

- Energy saving up to 60-80% compared to ordinary light
- Return on investment: 3 months



## ► FULLY AUTOMATICAL STIMULATION OF SOWS

Fully automatical stimulation of sows in connection with insemination. The stimulation takes place in two stages - in two programs.

The first program starts automatically when Stimulus is turned on - this program makes the first coarse stimulation of the sow.

Stimulus performs heavy pressure on the back and in the loin area. Like the boar would have done, if it had the task.



STIMULUS	
Article no.	Description
560520	STIMULUS
560521	MULTIHOLDER FOR STIMULUS



# INN-O-FLEX

## Penning equipment for sows and boars

INN-O-FLEX is a flexible penning program for sows and boars. The equipment is 110 cm high and mounted on 5x5 cm galvanized posts. Both 35 mm and 40 mm board profiles as well as 10 mm solid panels can be used.

There are vertical or horizontal pipes at the top of the equipment, that close tightly over the board profiles. Likewise, stainless steel U-profiles with inwards curved edges reduce the risk of manure penetration between U-profiles and board profiles. It ensures a better durability and makes it easier to keep the equipment clean.

### FACTS

Height	110 cm
Posts	5 x 5 cm galvanized
Board profile thickness	35 / 40 mm
LDPE plate thickness	10 mm
U-profiles	1,5 mm stainless steel
Pipes	33,7 x 2,65 mm hot galvanized
Gate handle	Twistlock / Pinlock

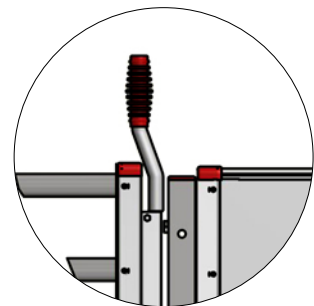
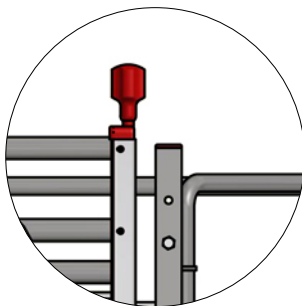

### ▲ 2 TYPES OF GATE HANDLE

Choose between pin lock or twist lock.

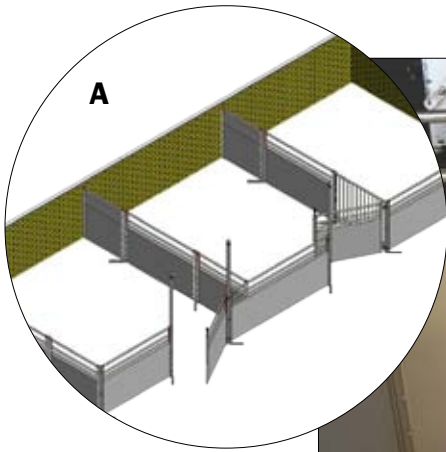

**A: 35 MM PVC BOARD PROFILE  
- H 110 CM**

- Flexible
- Easy to adjust on site
- Strong 50 mm posts
- Recommended for gilts and young females

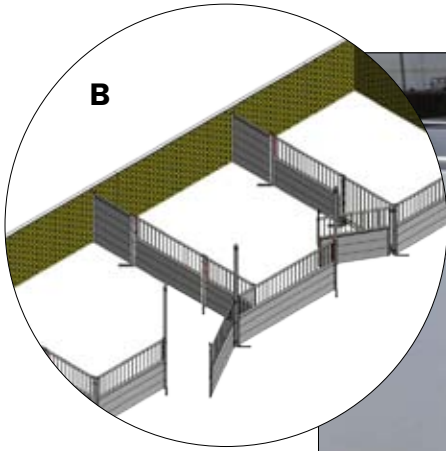

**B: 40 MM PVC BOARD PROFILE  
- H 110 CM**

- Very durable
- Twice as rigid as 35 mm
- Strong 50 mm posts
- Recommended for boars and sows

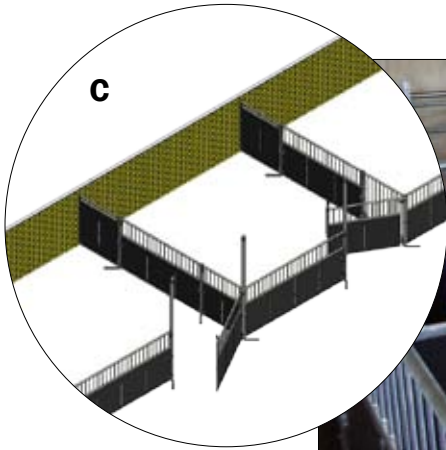

**C: 10 MM SOLID PANEL  
- H 110 CM**

- Space efficient
- Very stable
- Strong 50 mm posts
- Fully welded equipment
- Recommended for boars and sows
- Customer adapted



**D: COLLECTION PEN FOR  
BOARS**

- Easy passage
- Can be used as separation between the pens to sows
- Good overview
- Quick exit
- Security for the employees



# FUNKI FARROWING PEN

Spacious sow crate

**FUNKI F207** is our traditional farrowing pen. Sow crate with plenty of space for even the largest sows, both in the front and in the back.



## ▲ SOFT REAR GATE

The farrowing pen has one special detail - a soft rear gate. The rounded design takes care of the sows' rear part and provides plenty of room during the farrowing.



## ▲ OPENABLE REAR PART



## ▲ TILTABLE REAR PART

During farrowing and the next couple of days, the rear part can be tilted to cover openings in the slats, so that piglets do not get stuck.

# FUNKI FARROWING PEN

Traditional farrowing pen

- Sow cage with extra space for even the largest sows
- Maximum space for nursing piglets
- Large piglet nest: there is plenty of room for all piglets
- Simple and effective adjustment of the sow box
- Plastcoated soft rear gate - gentle to sows
- Tilt function of the rear part for greater safety during farrowing
- Extra large piglet nest for larger litters
- Delivered as side pens
- Strong construction with 50 x 50 mm posts



## FACTS

Pen length	2500 / 3000 mm
Pen width	1600 / 1650 / 1700 / 1750 / 1800 + variable 1600 - 2000 mm
Pen height	500/750 mm
Profiles	U-profiles 1,5 mm stainless / H-profiles
Board profiles	35 x 250/750 mm
Width, front	560 mm
Width, rear gate	520-700 mm
Height crate side	1100 mm
Crate side	33,7 x 2,69 pipe
Volume trough	21 liter
Piglets nest width	800/900 mm
Piglets nest area	0,9 / 1,0 m <sup>2</sup>

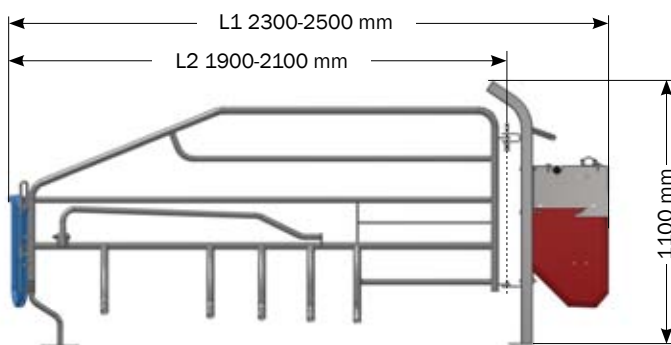
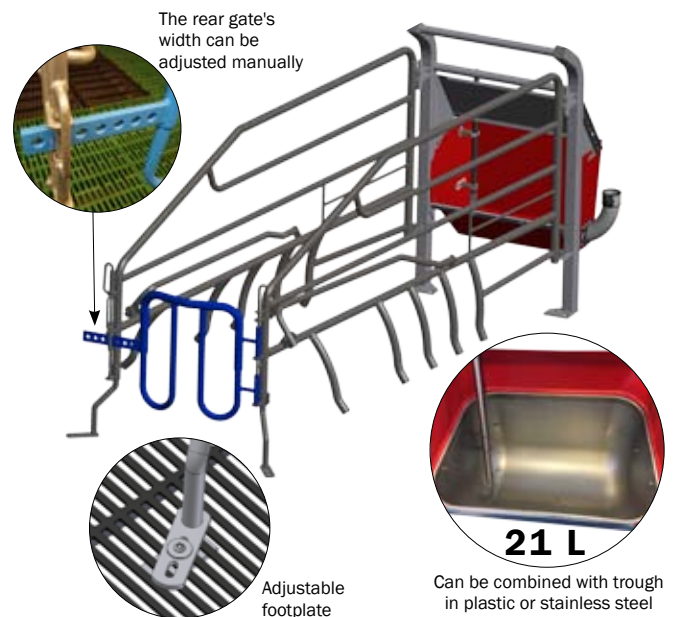

Farrowing partition F207 with tiltable wing  
L1 (incl. rear gate): 2500 mm  
L2 (incl. rear gate): 2100 mm

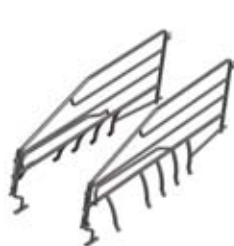

Farrowing partition F200S with tiltable wing, short model  
L1 (incl. rear gate): 2300 mm  
L2 (incl. rear gate): 1900 mm



Farrowing partition F200S without tiltable wing, with upper structure  
L1 (incl. rear gate): 2300 mm  
L2 (incl. rear gate): 1900 mm

## COMFORT CORNER PIGLET NEST

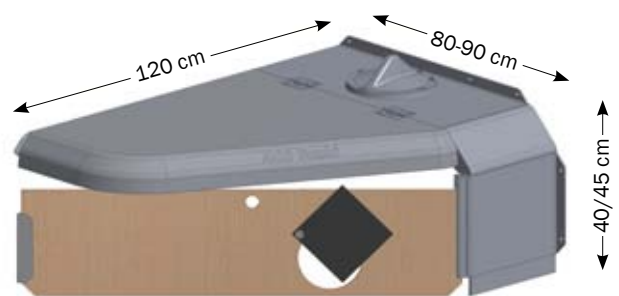

- Approved, high quality material: EPP
- Very smooth surface, easy to clean
- Minimum heat loss
- Hole in heating lamp, with lid
- Can be customized for your needs
- Piglets nest is available - facing right or left
- Width: 80, 85 and 90 cm
- Accessories: barrier plate (127x9 cm) with or without hole



# INN-O-CRATE FARROWING PEN

Spacious farrowing crate.

Many weaned pigs, high weight at weaning



## UNIQUE SOW TROUGH

The design and mounting of the sow trough makes it possible to have a limited or no casting so that the sow can utilize the space below.

## ► FRONT EXIT

Option for front exit. In addition, with tilt function.

## ◀ "SAFE TILT TROUGH"

The farrowing box is available with tiltable trough, making it very easy, safe and ergonomic to clear the trough using a handle.



INN-O-CRATE is also available as side-facing model as well as with front exit. Contact us for more information.



## Testimonials:

“ We produce more than 40 weaned pigs pr. year sow in INN-O-CRATE farrowing crates.”

Martin Andersen, Risgaarden, Viborg, Denmark  
2.150 sows, 83.000 weaned pigs

# INN-O-CRATE FARROWING PEN

Traditional farrowing pen with multi-adjustable farrowing box

- Many weaned pigs
- High weight at weaning
- The farrowing box is adapted to the anatomy of the sow and can be adjusted to the size of the sow. This means safe farrowing and lying down/getting up behavior
- The design of the box side ensures that the piglets get unrestricted access to the nipple
- Tiltable wings minimize the risk of piglets crushing
- Smooth, easy to clean surfaces and rounded corners minimize the risk of dirt collecting
- Strong and well-proven construction that has taken the starting point in optimum overview and access for staff



## FACTS

Pen length	2500 - 3000 mm
Pen width	1600 / 1650 / 1700 / 1750 / 1800 + variable 1600 - 2000 mm
Pen height	500 mm
Profiles	U-profiles 1,5 mm stainless
Board profiles	35 x 500 mm
Lying length	2000 - 2100 mm
Width farrowing crate, front	520 - 610 mm
Width farrowing crate, rear	580 - 850 mm
Height crate side	900 mm
Crate side	33,7 / 42,4 x 2,65 pipe
Volume trough	21 liter
Piglets nest width	800 / 900 mm
Piglets nest area	0,7 / 0,8 m <sup>2</sup>

The rear gate's width can be set in 10 positions

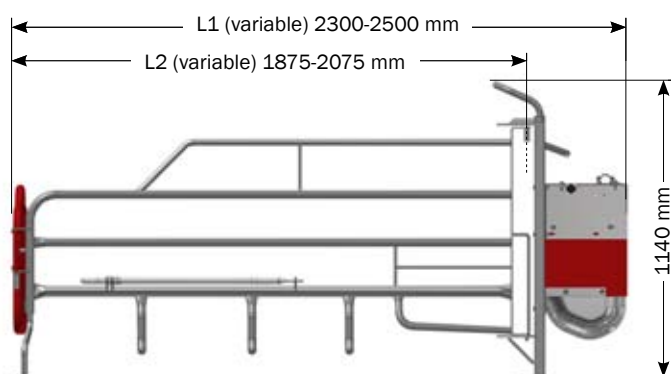

## SETTINGS

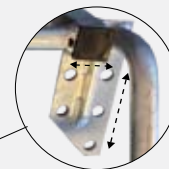
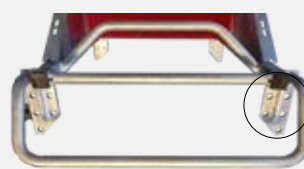

The width of the box can be varied by placing the wings in the inner or outer holes.

**Variable width:** 580/670 mm.

The length of the box is varied by mounting in the different holes.

**Variable length:** Can be extended / shortened by 50 or 100 mm.

## INN-O-CORNER PIGLET NEST

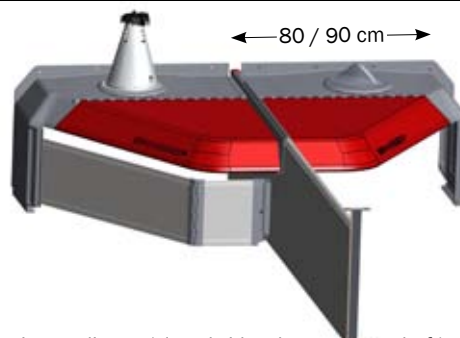

XL standard, with tiltable wings  
L1 (incl.rear gate): 2400 mm } + 50 or  
L2 (incl.rear gate): 1975 mm } 100 mm

XL short, with tiltable wings  
L1 (incl.rear gate): 2300 mm } + 50 or  
L2 (incl.rear gate): 1875 mm } 100 mm

XL standard, with tiltable wings and upper structure, export  
L1 (incl.rear gate): 2400 mm } + 50 or  
L2 (incl.rear gate): 1975 mm } 100 mm

XL short, with tiltable wings and upper structure, export  
L1 (incl.rear gate): 2300 mm } + 50 or  
L2 (incl.rear gate): 1875 mm } 100 mm

- Optimum climate (closed sides that prevents draft)
- Tight assemblies and close connection between lid and fixed part
- Up to 0,8 m<sup>2</sup> covered area
- Individual adjustment possible
- Easy access
- Light construction
- Piglet nest can be right- or left-handed
- Width: 80 and 90 cm

# HEATING LAMPS FOR FARROWING PENS

Warm environment for piglets

## HEATING LAMPS FOR COMFORT CORNER



### ▲ ADAPTER-RING

For all types of lamps

#### Description

- Heating lamp 21 cm 2,5 m cable, reg. plug
- Heating lamp 21 cm, 2,5 m CE-plug
- Lid for heating lamp
- Lock plate for heating lamp



## "MASTER LAMP" HEATING LAMP

- The only heating lamp on the market that meets all requirements
- Splash proof (IPX4)
- Fine distance in dome shaped net < 50 mm
- Bayonet socket - easy to mount on the cover of the creep box
- Available with CE- and regular plug

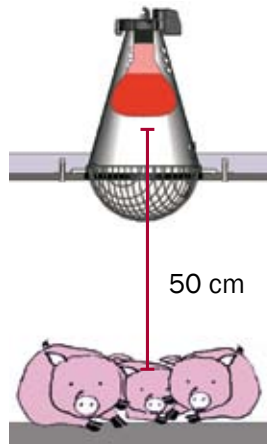

#### Description

- MASTER LAMP with reg. plug without ground
- MASTER LAMP with CE-plug
- Heating bulb 100 watt, 12 pcs.

## "MASTER HEATER" HEATING LAMP

- **Reduced energy**  
Reducing energy consumption in the stables by up to 50% when combined with dual control.
- **Even distribution of heat**  
Providing more equal distribution of heat than traditional heat lamps. This ensures better feed intake and a higher survival rate amongst piglets, as well as a reduction in use of medicine.
- **Waterproof IPX9K Approved**  
Easy to clean and maintain. A high pressure cleaner is used for cleaning the Master Heater which means you don't have to disassemble the Master Heater. This helps in maintaining a high hygiene level.
- **Life expectancy**  
As apposed to traditional heating lamps there is no use of incandescent bulbs for the Master Heater. 1 year warranty.
- **Low fire risk**  
Master Heater obtains a lower temperature than traditional heating lamps, which reduces risk for fire.

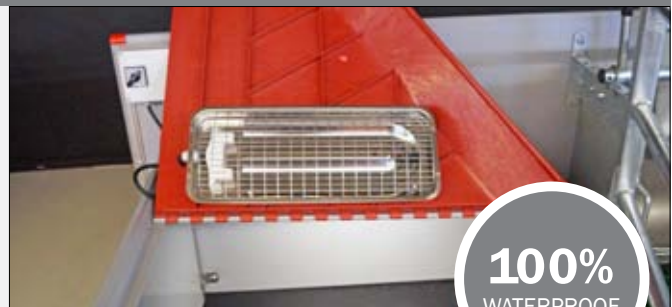

### MASTER HEATER Incl. 240 cm cable

#### Description

- MASTER HEATER 100W without plug
- MASTER HEATER 150W without plug

#### Control

- Double contact for 2 MASTER HEATER
- Multi contact for 16 to 18 MASTER HEATER

## INTELLI HEAT Smart controller for heating lamps



- Infrared temperature sensor measures the temperature of the pigs body when they are in the piglet nest, and the floor when the nest is empty.
- Ensures constant optimal temperature conditions
- Lower mortality because the piglets stay in the piglet nest
- Higher weight at weaning
- Significantly lower energy consumption than without heat management
- For farrowing and weaner pens
- Can be used to control other heat sources

See also our selection of heating plates under "Flooring"



# ACCESSORIES FOR FARROWING CRATE

Water supply for sows and piglets

## WATER SUPPLY FOR SOW

Water supply	1" galvanized or stainless steel pipes
Water pipe for sow	23 mm SS pipe, stainless bracket and drill clamp
Nipple for sow	Stainless steel nipple, 1,3 liter per minute

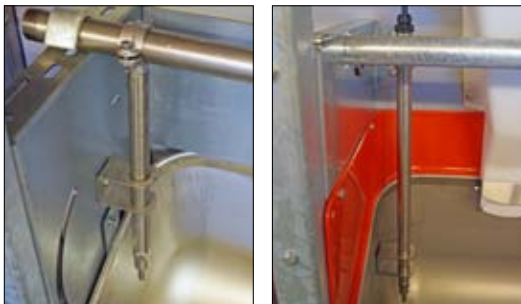

### ▲ STAINLESS / PVC WATER SUPPLY



### ▲ EB WATER - CLAMP FITTING



### ▲ DRINKING CUP FOR SOW AND PIGLETS



### ▲ SUCKLING/BITE VALVE (MANUAL)

## WATER SUPPLY FOR PIGLETS



### ▲ VIP-O-MAT DRINKING CUP

- Cast solid and hygienic combination in strong and easy to clean plastic and stainless steel
- Top hygiene: the bottom plate can be tilted for emptying and cleaning
- Easy assembly
- Connected to sow water or separate



### ▲ DRINKING CUP FOR PIGLETS

- Stainless steel with height adjustable drinking valve
- No sharp edges = less accumulation of dirt and better hygiene
- Connect to water for sow



### ▲ DRINKING NIPPLE

- Casted solution in plastic with stainless bite valve
- Easy to mount, clean and maintain
- Complete with hoses and fittings for the water supply
- Connect to water for sow



### ▲ DRINKING CUP WITH STAINLESS PLATE

- Reduced water pressure; therefore very gentle for piglets
- Connect to separate water supply via reduction valve
- Stainless steel

# FARROWING PENS

Different types of pens for every need

We offer more solutions when it comes to the construction of farrowing pens. The farrowing pens can be constructed with different types of board profiles, each with its special characteristics and thus for different specific needs. Below you can get an overview of our standard solutions, so you can choose the solution that best fits your stable. Of course, our sale managers are always ready to guide you.

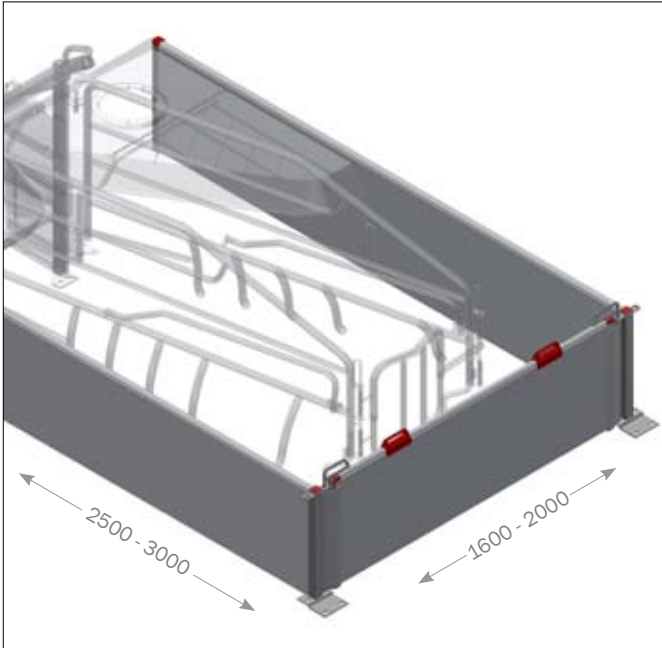

## ▲ GALVANIZED FARROWING PEN

The pen with strong, galvanized posts. Easy to open. Easy to clean. No sharp edges and corners where hoses can hang onto during washing. Tiltable rear part operated with one hand.

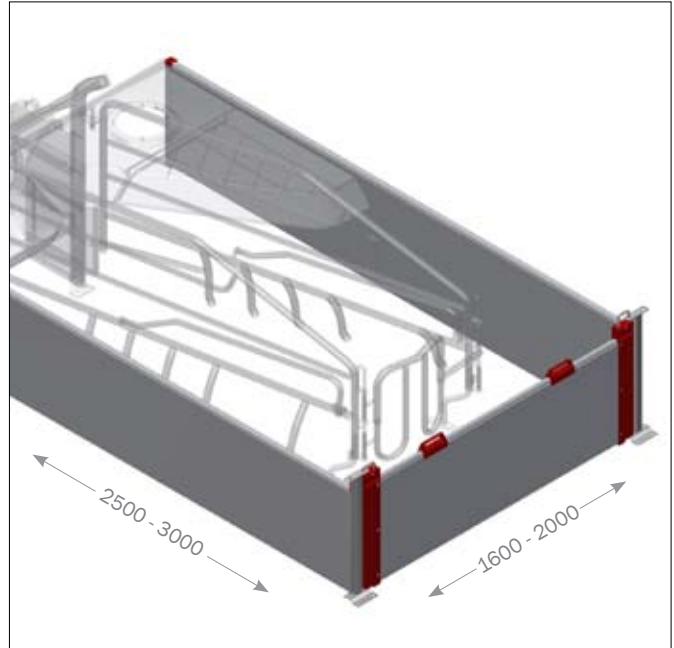

## ▲ STAINLESS FARROWING PEN

The pen with stainless steel bars and fittings. Easy to open. Easy to clean. Tiltable rear part operated with one hand.

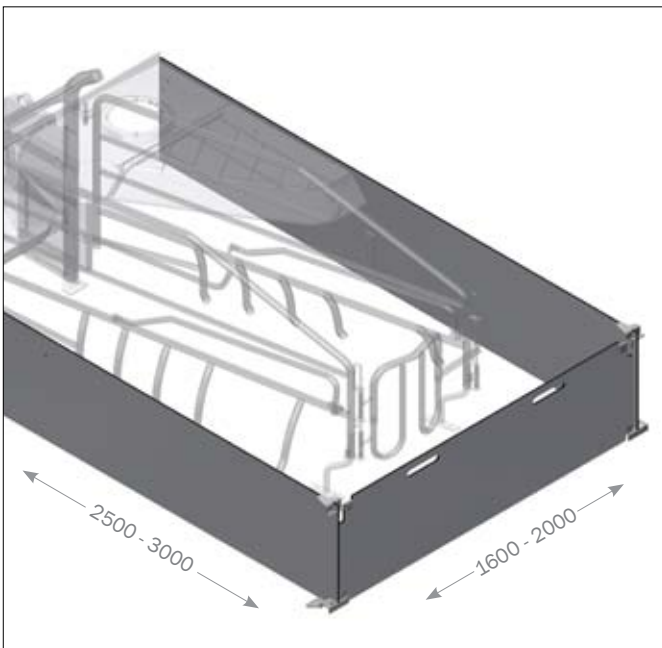

## ▲ FIBRE FARROWING PEN

The pen built of solid panels with good resistance to diseases and bacterial infections. Fittings in steel. Easy to clean. No sharp edges and corners where hoses can hang onto during washing. Considerably thinner board profiles, which gives more optimum space utilization as well as more pen space per m<sup>2</sup>.

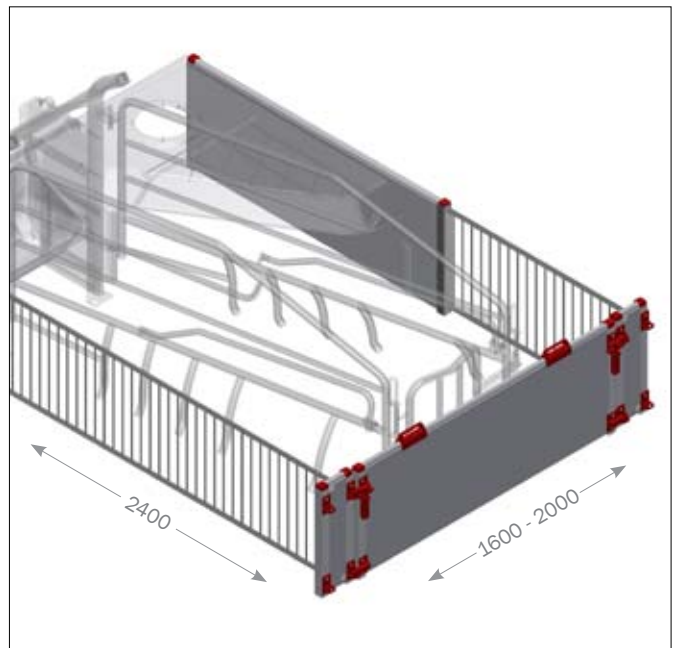

## ▲ OPEN FARROWING PEN

An open pen with grille. The solution contributes to a good natural ventilation through the pen, and is specially developed for warm climates. Rear part with lock operated with one hand. Strong construction. No sharp edges and corners where hoses can hang onto during washing.

## SOW TROUGH

- Large capacity: 21 liters
- Suitable for new and existing farrowing pens
- Durable and hygienic: folded and closed edges that resist even very strong impacts
- No welds that can make injuries on sows
- No blind corners where feed residues can accumulate



### FACTS

Capacity	21 L
Material	1 mm SS 18/8 quality
Holes	2 x Ø9 in each side
Weight	3,6 kg

## BIOLINE TROUGHS



- With head/shoulder partition
- For partition and wall mounting
- From 4 to 7 pigs per eating place
- Ad libitum feeding
- Strong stainless trough
- Gentle to pigs
- Long durability

### FACTS

Options	With 5,7 or 9 eating places
Material	Fiber plate, 10 mm
Size per eating place	220 mm

### BIOLINE TROUGHS

Article no.	Eating places	Dimensions (H x D x W, mm)
39902	5x2 eating places	750 x 1100 x 430
39912	7x2 eating places	750 x 1600 x 430
39922	9x2 eating places	750 x 2000 x 430

## FEED BOWLS FOR PIGLETS AND WEANERS

### FEED BOWLS FOR PIGLETS AND WEANERS

Article	Description	Volume
90012	Mini feeder in plastic incl. fittings	1 l
90013	Mini feeder in plastic incl. nut/bolt	1 l
90144	Suspension bracket for mini feeder	-
96061	Feed bowl in plastic for piglets. Ø260 mm.	1,5 l
96063	Feed bowl in plastic for piglets and weaners. Ø390 mm	4,5 l
560395	Feed bowl Ø24 SS with hook	2,5 l
06906	Round bowl FTK 27 with cone and inner rim	
03186	Feed bowl FT 19, H:80 mm, Ø190 mm	
554154	Feed bowl 326-T, H:60 mm, Ø260 mm	

- Easy to mount: round feed bowls are mounted with a spring loaded holder on the cast iron slat. Feeding pan for hanging are mounted with screw/bracket.
- Everlasting materials: plastic and stainless steel
- Hygienic: easy to reach corners - easy to clean





# WELSAFE

Space-saving farrowing pen for loose sows.  
Higher weight at weaning

## FOCUS ON ANIMAL WELFARE

Welsafe farrowing pen is designed to ensure the best conditions for both sows and piglets. The sow has the opportunity to move freely in the pen and it is only fixated within a few days before and after the farrowing.

- Significantly higher weight at weaning. Test results show an increase of 1 kg by weaning
- WELSAFE is our unique space-saving farrowing pen for loose nursing sows
- The pen can be built in both new and existing stables
- Inspection access between the farrowing crate and the piglet nest - not necessary for employees to come in to the sow
- Good space for milking system for piglets
- Swivelling sides allow short-term restraining, that reduces piglets' mortality
- The sides can also be used as flexible protection during inspection of the sow
- Height-adjustable barrier plate in the piglet nest

### ► SHORT-TERM RESTRAINING OF SOW

Swivelling sides allow short-term restraining of sow just before and after farrowing to protect the piglets and staff.





**◀ INSPECTION ACCESS**

Good space between farrowing box and piglet nest gives inspection access, so that it is not necessary for employees to come in to the sow. The distance between farrowing box and piglet nest can be adjusted by means of the special fitting.

**PIGLET NEST ▼**

The piglet nest is designed to be used both towards the wall and aisle.



**PVC CORNER TROUGH**



**STAINLESS STEEL CORNER TROUGH**



**◀ CORNER TROUGH FOR SOW**

The trough is designed to fit with U-profile in the corner. Hereby closing completely to wall/inventory in front of the trough. Choose between PVC or stainless steel. The trough's capacity is 19,5 l.



# FT-30 FARROWING PEN

Many years of experience for loose sows

**FT-30 FARROWING PEN** was designed based on the Norwegian preferences for loose nursing sows. The result is a very flexible pen that can be used from birth to piglets weight of approx. 30 kg. The pen contains a piglet nest with a lid designed in a fiber plate. The lid comes with or without hole for heating lamp



## ◀ FT-30 = FROM BIRTH TO 30 KG

By applying the "birth to 30 kg" system, you avoid transportation of piglets to the weaner unit. It means a lot less cleaning in comparison to traditional production. At the same time you save the pigs from stress, which gives a better daily gain and feed conversion.

FT-30 PEN		PIGLET NEST	
Pen length	300-340 cm	Width	110 cm
Pen width	240-260 cm	Area	1 m <sup>2</sup>
U-profiles	2 mm stainless	Lid	with or without hole



## ▼ BOARD PROFILE OR FIBRE PLATE

FT-30 pen can be made of 35 mm PVC board profiles or 10 mm fibre plates.

DIMENSIONS	BOARD PROFILE	FIBRE PLATE
Side height	100 cm	96 cm
Rear part height	75 / 100 cm	61 / 75 / 96 cm
Gate height	100 cm	96 cm
SS bars height	100 cm	96 cm

# PENNING EQUIPMENT FOR WEANERS AND FINISHERS

With CLEAN-O-FLEX, FUNKI FIBER AND FUNKI FLEX equipment from ACO FUNKI you have many design options for weaners and finishers



**CLEAN-O-FLEX**



**FUNKI FIBER**



**FUNKI FLEX**



# CLEAN-O-FLEX®

## Well-sealed equipment

CLEAN-O-FLEX® is a flexible system based on stainless U-profiles. With standard height of 75 and 100 cm it can be used especially for weaners, WEAN-TO-FINISH and finishers.

### ▼ WEANERS

The height of the CLEAN-O-FLEX equipment for weaners is 75 cm. Delivered in assembled units up to 360 cm. For length above 280 cm, retaining bracket is required.

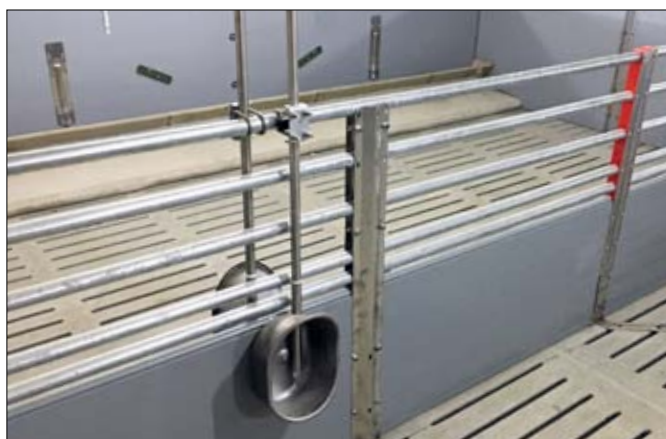
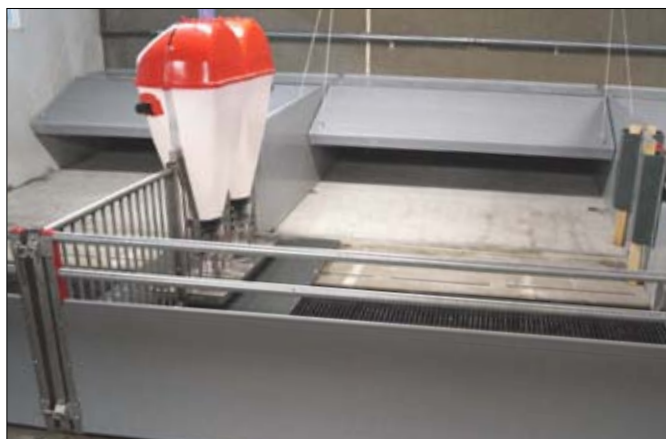

### SUPERIOR PRODUCTIVITY

- Focus on finish: plastic plugs, rubber sealing and locking system ensure completely tight and closed equipment everywhere. It ensures the possibility for easy and effective cleaning and thus new stall effect whenever the pen is washed.
- Rounded edges and corners ensure animals welfare.

### TYPE OVERVIEW - options

Height, mm	Pin lock	Twist lock	Full width gate	Qty of pipes	Closed
750	-	x	x	2	x
850	x	-	-	3 / 1	-
1000	x	x	x	5 / 2	x

### U-PROFILES

1,5 mm stainless steel in patented design

### PVC BOARD PROFILES

35 mm with patented zig-zag reinforcement

### PIPES

33,7 x 2,65 mm hot galvanized

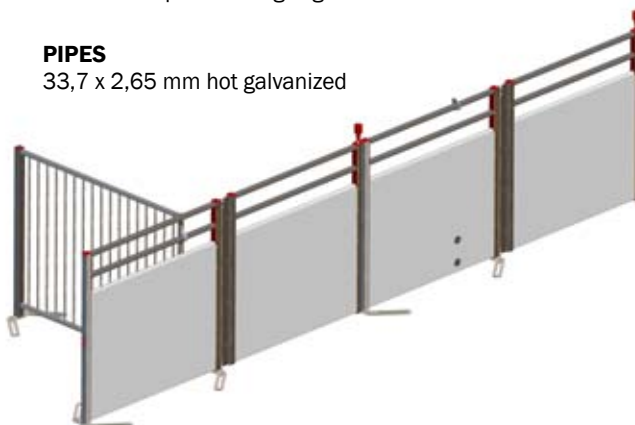

### ◀ FINISHERS AND WEAN-TO-FINISH

The height of CLEAN-O-FLEX® equipment for finishers and Wean-to-Finish is 100 cm. The equipment is delivered mounted up to 360 cm. For length above 250 cm, stiffening bracket is required.



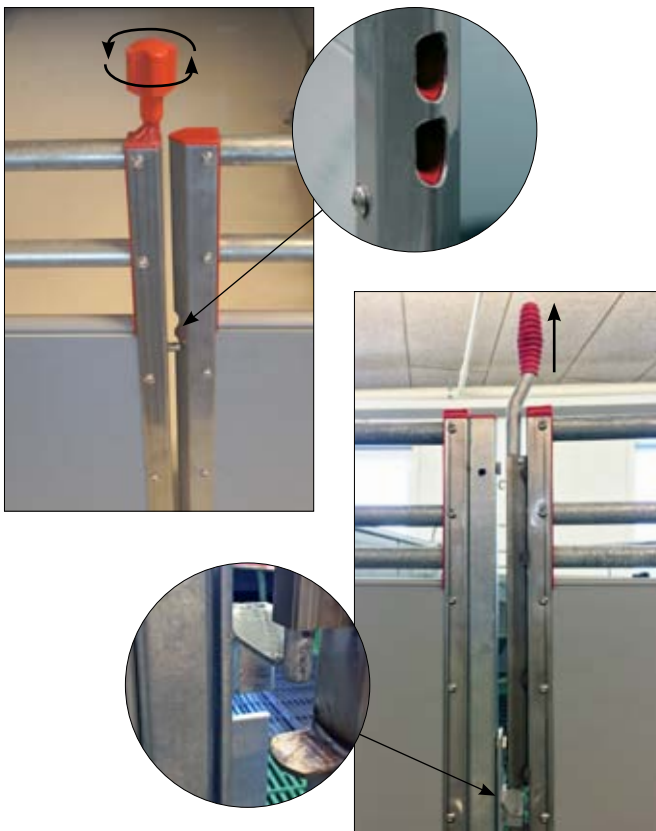

## ▲ SUPERB FUNCTIONALITY

- Gates can be operated with one hand and can be slammed - it saves time
- Innumerable combinations and still the pen function and unity is kept
- Cross-functional solution for all pen units with growing pigs

## ▲ NO MANURE IN THE AISLE

The gates are mounted on sloped hinges, so that they raise at opening. When closed, the gates fit tightly to the floor and prevent manure in the aisle.



# FUNKI FIBER

Solid fibre plate reduces risk of infection

**FUNKI FIBER** is our penning equipment for weaners and finishers. The core in the equipment is a 10 mm massive compact panel, which, despite its thickness, is an extremely strong and durable material.

The entire construction is made of the compact panels without posts, and all the pipes end with the PVC adapters or plugs. It helps to reduce accumulating of manure in the difficult accessible places.

TYPE OVERVIEW	Height, mm		
	750	875	1000
Compact panel and 1 top pipe	x	-	-
Compact panel and 2 top pipe	-	x	-
Compact panel and 3 top pipe	-	-	x
Suspended gate	x	x	x
Gate in full width	x	x	x

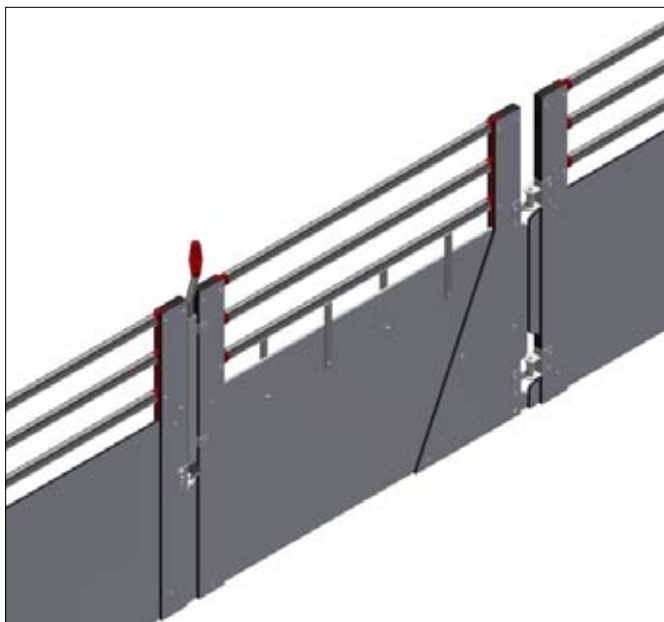

FUNKI FIBER with the regular suspended gate

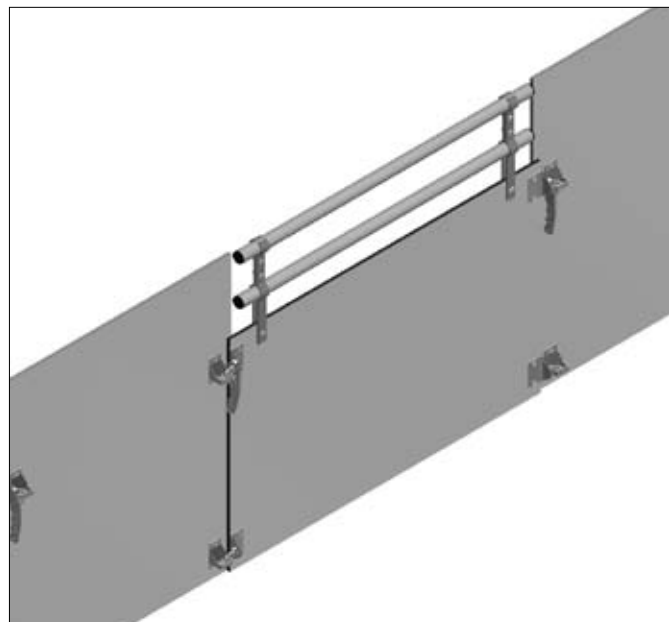

FUNKI FIBER with the gate in full width

## ▼ DURABLE MATERIAL

FUNKI FIBER equipment is made of fiber panels that have a thickness of only 10 mm. It gives more space for pens without compromising on quality. Fiber panel is very strong and impact resistant material.

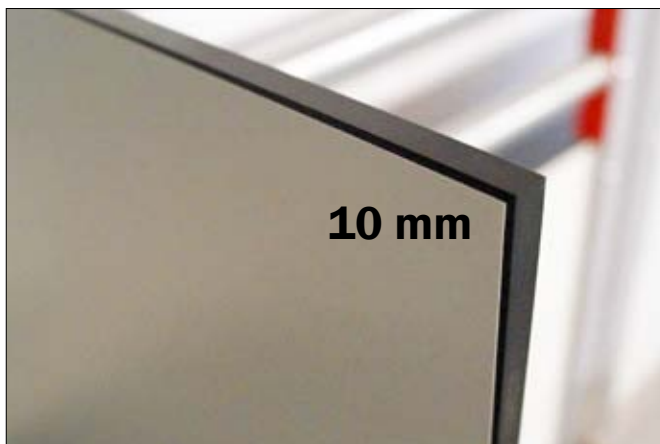

## ▼ SOLID EQUIPMENT

FUNKI FIBER equipment is made of fiber panels, where all edges are rounded to minimize the risk of injuries. The closed equipment contribute to a specially good hygiene and have bactericidal properties.



## ▼ GATE - REGULAR

It is easy to open the gate by means of pin lock.

## ▼ GATE - FULL-WIDTH



## ◀ FARROWING PEN FOR LOOSE SOWS MADE OF FIBRE PANELS

Available in many options for many purposes.



# FUNKI FLEX®

## Penning equipment for weaners and finishers

**FUNKI FLEX** is our flexible penning system for weaners and finishers, and it is made of corrosion-free materials, PVC and stainless steel. The PVC board profiles are closed at the top and at the bottom. Strong foot plates in stainless steel or cast iron.

FUNKI FLEX has a height of 75 cm for weaners and 100 cm finishers.

### STRONG GATE

FUNKI FLEX is available with a gate, where the edge is reinforced by stainless steel U-profile.

TYPE OVERVIEW - variations				
Height, mm	Pin lock	Full-width gate	Qty pipes	Closed
750	x	x	2	x
1000	x	x	1	x

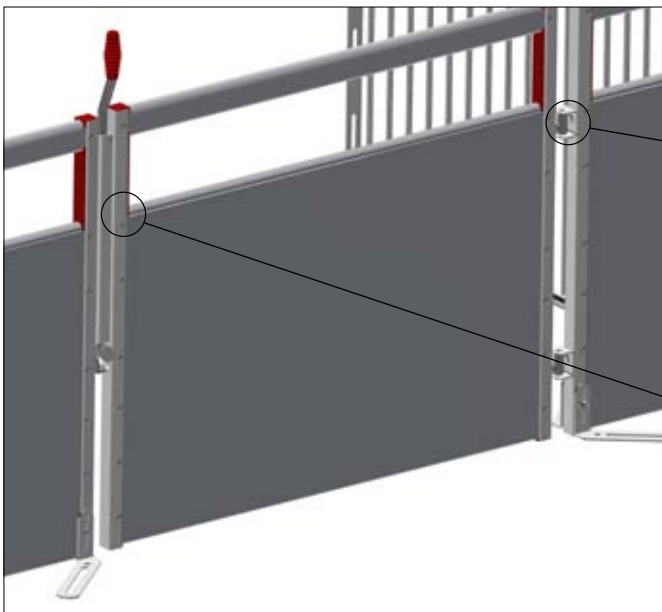

*The gate operated by one hand, which makes it easy to take some animals out of the pen. It is closed towards aisle, preventing manure residues in this area.*



**▲ HINGES**  
Strong, reversible stainless steel fittings



**▲ STEEL REINFORCED EDGES**  
U profile in stainless steel



### ▲ STRONG CONSTRUCTION

FUNKI FLEX is made of 35 mm strong PVC that does not rust or break. Stainless steel screws ensure that the pigs do not get damaged. The FUNKI FLEX equipment has no sharp edges and has warm and animal-friendly surface. Quick drying and reheating after washing.



### ▼ STRONG HINGED GATE

The gate can be operated with one hand, which makes it easier to take single animals out of the pen. Closed towards aisle, which means no manure in the aisle.



### FUNKI FLEX UNASSEMBLED

FUNKI FLEX equipment can be delivered unassembled. It is easy to mount, as many details are connected with a "click" system. Flexible equipment with many options.



- Plastic with rounded profiles all over and thereby no sharp edges
- Light, but at the same time durable construction with 15 mm plastic board profiles
- Tight fittings ensure top hygiene and easy cleaning; developed for modern pig production
- Designed for modern pig production; can withstand frequent washing
- Hinge rails with flexible rubber hinge ensures draft-free environment
- Many combinations and built-in options

# FLEXCOVER® climate cover

All advantages in one product

## FLEXCOVER climate covers

FLEXCOVER is a climate cover for weaner units, that consists of the fixed part and the openable part. FLEXCOVER has many built-in options with 25, 50 and 75 cm board profiles in combination with flexible hinge rails. The climate cover is made of 15 mm PVC board profiles and is available in different variations as 2-parts, 3-parts or sloped.

FLEXCOVER - overview			
Depth, mm*	Type	2-parts, mm	3-parts, mm
850	Straight	250/500	-
1100	Straight	500/500 + 250/750	-
1160	Straight	-	250/500/250
1350	Straight	500/750	-
1600	Straight	750/750	-
1100	Sloped	250/750	-
1350	Sloped	500/750	-

\* Max width is 300 cm. If the width is more than 300 cm, an extra post is required.



## ▼ OPEN/CLOSE-FUNCTIONS

FLEXCOVER can be opened and closed by means of whether electrical motor or hand winch.



El-motor for central lifting



Hand winch, complete 500 kg

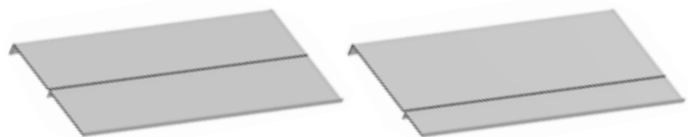

2-parts 500 / 500 mm

2-parts 250 / 750 mm



2-parts, sloped 250 / 750 mm



3-parts 250 / 500 / 250 mm

## CLEAN-O-FLEX® PVC BOARD PROFILES

- **Pressure and twist stable**  
Zig-zag lamellas give a high degree of stability compared to regular panel division
- **Durable**  
Pure, new lead free PVC (differences in color can occur)
- **Tight joints**  
Rubber strip is glued to the upper edge of the panels
- **Simple and fast mounting**  
Rational click system
- **Easy to clean**  
Tight, strong and smooth surface and rounded bottom

TYPE OVERVIEW	Dimensions	
Description	Height x Width, mm	Length, m
CLEAN-O-FLEX PVC board profiles 35 mm	35 x 250	6 m / running m
	35 x 500	
	35 x 750	
<b>40 mm. Extra strong. For sows, gilts and boars</b>		
PVC board profiles 40 mm	40 x 200	6 m / running m
	40 x 500	

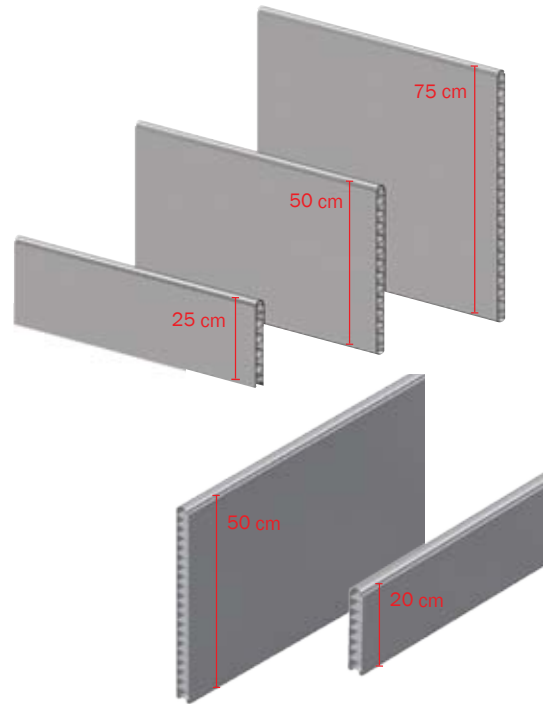

## PROF LINE STEEL PROFILES & PVC LINE PROFILES

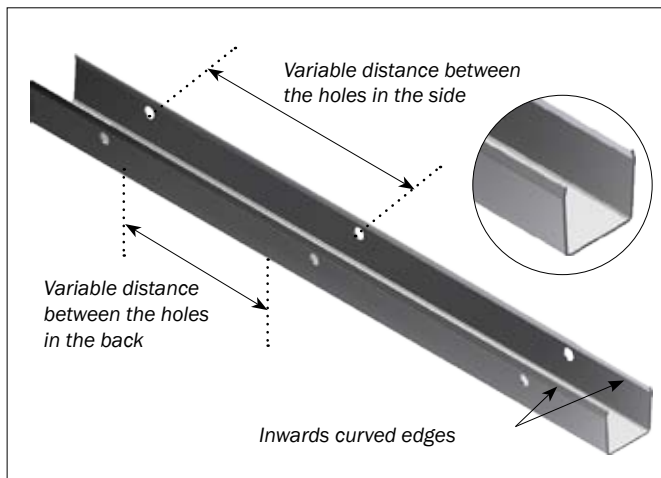

\* U-profiles are available in tailor-made length. Distance between the holes as well as the holes' shape can be adjusted to your needs.

Contact us for more information.

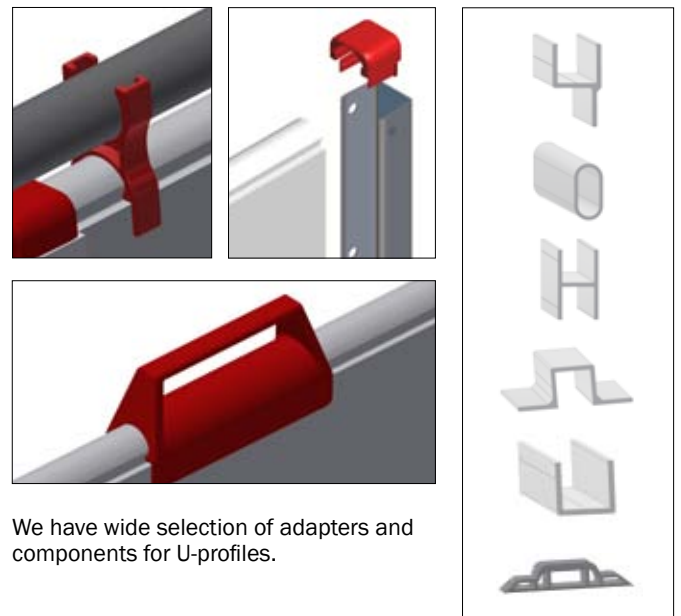

We have wide selection of adapters and components for U-profiles.

## INN-O-PLUG

INN-O-PLUG is a system for fixation of foot brackets, slats and concrete slats and for mounting of equipment parts.

- **Everlasting**  
Stainless steel
- **Low damage risk**  
Rounded screw and bolt heads
- **Easy to mount**  
Designed for use of torx-tools - more sturdiness
- **Do not get loose**  
Due to coating the bolts stay tightened

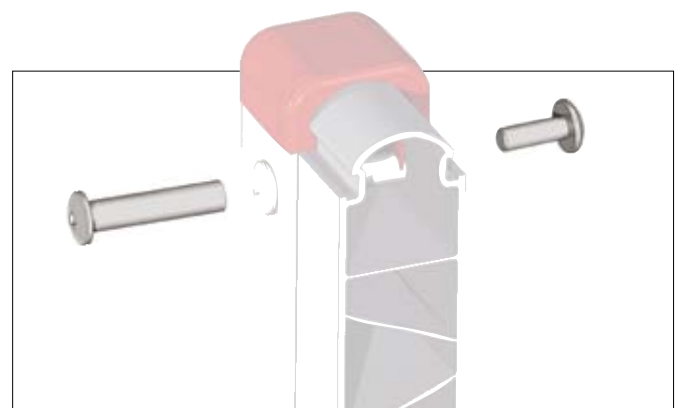



- More opportunities to meet the requirements for manipulating material for the pigs
- Solutions for weaners, finishers and sows
- Minimizes the risk of, for example, tail biting and other inappropriate behavior
- Supports the pigs' natural behavior

# MANIPULATING MATERIALS

Meet pigs' needs to investigation behaviour

Pigs investigate their surroundings by performing digging, sniffing, biting and chewing movements. Therefore, a lack of investigation and manipulation materials can adversely affect the behavior of the pigs. Some weaners and finishers develop tail biting behavior that is related to their current motivational state.

Therefore, the current Danish legislation set up the minimum standards for the protection of pigs. According to the current rules, "pigs must have permanent access to a sufficient amount of materials that they can properly investigate and manipulate."

We offer several types of manipulation materials adapted to different types of pigs and pens.

► **STRAW RACK**  
*in fibre material*

For farrowing pens



▼ **HOLDER FOR MANIPULATION MATERIALS**

For finishers and weaners



► **STRAW RACK**  
*in stainless or galvanized steel*

For all pigs and pen types



◀ **HOLDER FOR MANIPULATION MATERIALS**

For farrowing pens





# FLOORING

Our floor program for farrowing pens, weaners and finishers give you innumerable combinations and solutions



# COMBI-FLOOR

Plastic slats for COMBI-FLOOR



## Combine according to your needs

- Flexibility and maximum hygiene in farrowing unit
- Fully drained floor
- 100% new PP-plast or cast iron

## Easy to clean

- Manure passage and easy cleaning

## Comfortable for both sow and piglets

- Plastic is warm and hygienic for the piglets
- Can be combined for ex. with unique drain plate made of cast iron under the sows shoulders to prevent compression damage



## PLASTIC SLATS FOR SOWS

ACO FUNKI sow slats are made of durable polypropylene material. The slats' surface structure is specially adapted to the animals anatomy, and it ensures very good slip resistance and, at the same time, high comfort.

## PLASTIC SLATS FOR WEANERS

### Plastic slats for weaners with 10% opening

The special plastic slate has an innovative surface structure and 10% opening. It helps the piglets stay warm and dry. In addition, it excludes the risk of their claws to be caught in the holes.

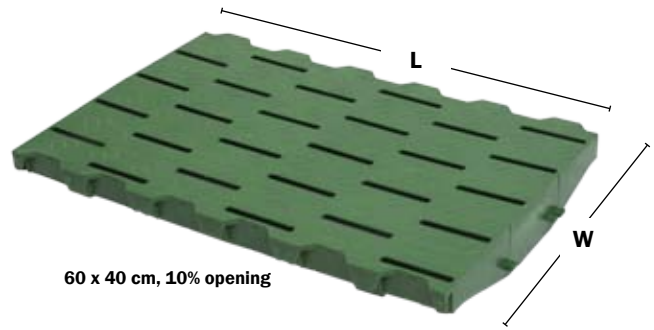

60 x 40 cm, 10% opening

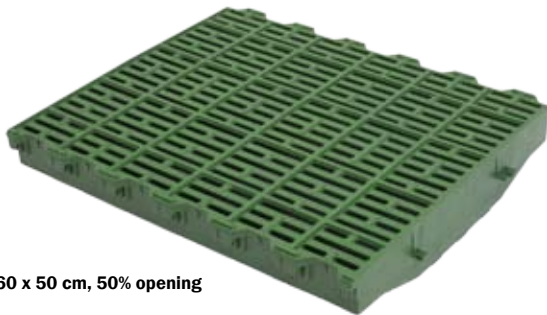

60 x 50 cm, 50% opening



60 x 40 cm, closed

## Testimonials:

“ New piglet farm was built in 2016, identical sections, the only difference is the floor.

The small details make the big difference: 6 hours washing time for ACO FUNKI floor vs. 7,5 hours washing time for not ACO FUNKI floor. It means 20% more washing time for the not ACO FUNKI floor. ACO FUNKI floor is also more stable and strong.

Karsten Kur Jensen, Risgaard, Viborg, Denmark  
2150 sows, 83000 weaners

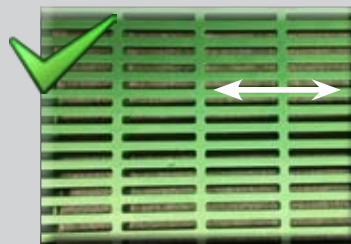

ACO FUNKI FLOOR:  
Washing time: 6 hours per section

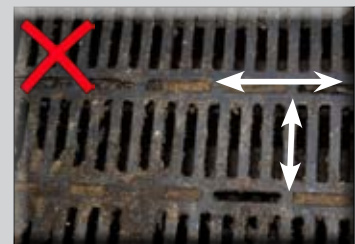

NOT ACO FUNKI FLOOR:  
Washing time: 7,5 hours per section

TYPE OVERVIEW - plastic slats for Combi-floor						
Description	Article no.	Length, cm	Width, cm	Closed	10%	50%
Plastic slats for sows	565060	60	50			x
	09102	60	40			x
	18054	10	40			x
	17383	60	40	x		
	18094	30	20			x
	17328	30	30			x
	18721	30	60			x
Plastic slats for weaners	17384	60	50			x
	09100	60	40			x
	18604	60	40		x	
	566160	60	60	x		
	566260	60	60		x	
	566360	60	60			x

TYPE OVERVIEW - cast iron slats for Combi-floor								
Description	Article no.	Length, cm	Width, cm	Closed	5%	50%	STEP	Plug
Cast iron slats for farrowing pens	566060	60	60			x		
	566063	60	60			x		x
	564060	40	60			x		
	563060	30	60			x		x
	561060	10	60			x		
	566040	60	40			x		
	566041	60	40		x			
	566042	60	60		x			
	564063	40	60	x				
	564061	40	60			x	x	
	564062	40	60	x			x	

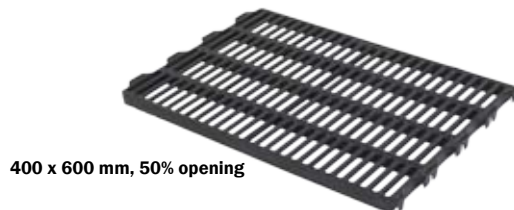

### ▼ STEP-SYSTEM

The STEP-system is especially designed to elevate the sow's lying area in order to reduce the risk of crushing the small piglets by the sow, thus, reducing piglets' mortality. Furthermore, customers' experience shows, that piglets have better conditions for nursing.

### Testimonials:

“ Increased productivity from 33,60 piglets per sow/year to 36,80 piglets per sow/year from January to August 2016.

This increase in productivity was reached after rebuilding their farrowing pens with ACO FUNKI's STEP-system. The farm has got several awards in Portugal for productivity.”

"Exploração Nuno Correia - Ota" farm, Portugal



# COMBI-FLOOR FOR FARROWING PENS

Moving Floor // Polymer plate



## ◀ MOVING FLOOR

The moving floor is specially designed for farrowing sows. The main purpose is to provide the best safety for both sow and piglets by minimizing the risk of crushing during farrowing.

The moving floor is stable, durable and designed to be combined with other flooring options from ACO FUNKI.



## ▼ POLYMER PLATE FOR SOWS

“COMFORT PLATE” is developed to help sows to cool off and at the same time to ensure dry surface. The plate is made of polymer concrete, so the surface is always non-slip without sharp edges.

The plate is supported and held in place by a specially designed plastic support, which ensures that the plate follows the floor surface. Comfort Plate can be used as a substitute for ordinary concrete tiles, if they have become rough in the surface.

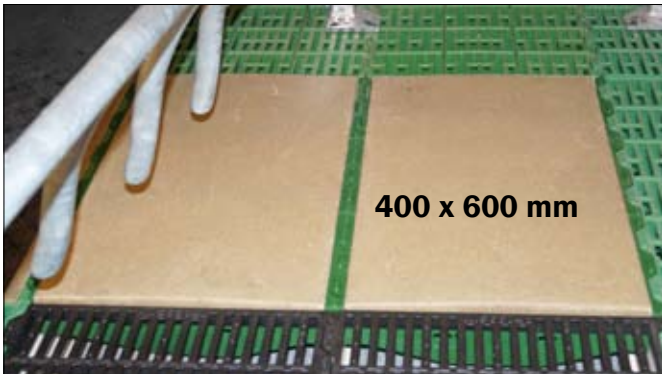

	“Comfort Plate”	Beton plate
<b>Durability</b>	+20 years	Max 5 years
<b>Risk for shoulder ulcers</b>	No or >0,1%	Big <5%
<b>Surface</b>	Soft	Will grow rough
<b>Absorbs moisture</b>	No	Yes
<b>Surface shape</b>	With small fall, water always runs down	No fall

Choose  
“Comfort Plate”



## Testimonials:



After installing the Comfort Plate under the sows, we have not seen shoulder ulcers.

Martin Holck Andersen Risgaard, Viborg, Denmark  
2200 sows, 41,2 psy

# COMBI-FLOOR FOR FARROWING PENS

Support and accessories

## ACCESSORIES FOR COMBI-FLOOR

We have of course all the accessories necessary for mounting and support of COMBI-floor - from fiber glass supports to anchors and fittings.

Contact us for a complete overview and price-list.

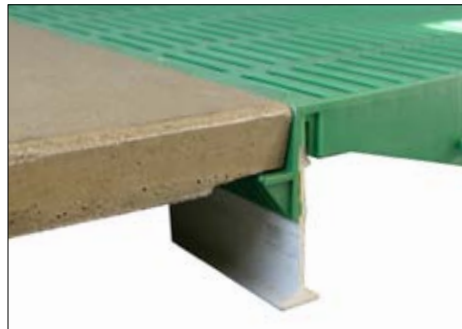
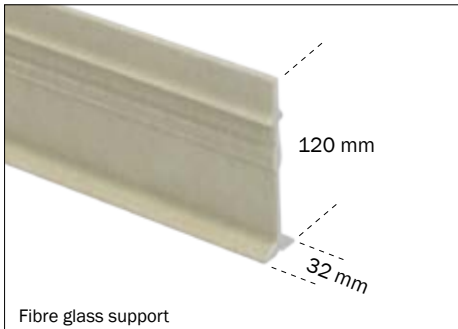

### ◀ STRONG FIBER GLASS SUPPORT Suitable for long farrowing pens

- Unique fiber glass profile
- Resistant to twisting
- High carrying capacity

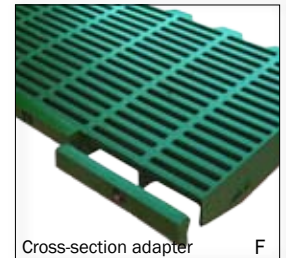
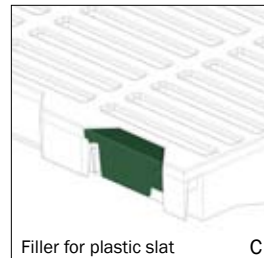
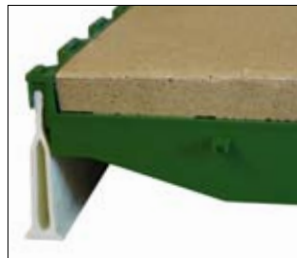
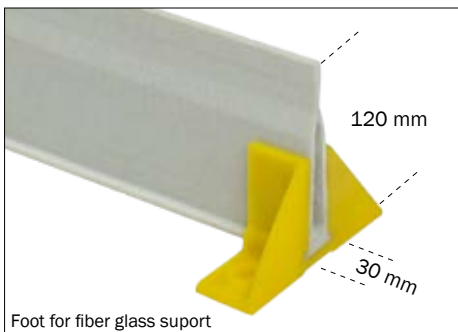

## ▲ DELTA SUPPORT

SUPPORT					
Description	Size (mm)	Max span length (cm)		Length (cm)	
Galvanized support for farrowing pens	50 x 5	<160			
	60 x 5	160-200			
	80 x 5	200-280			
	100 x 5	280-320			
	120 x 5	320-350			
		Weaners	Sows	w/cast iron under sow	
Fiber glass support for farrowing pens	70 x 32	160	120	-	600/spec. length
	120 x 32	280	240	260	500/550/600/spec. length
Fiber support for farrowing pens	70 x 32	-	-	-	590/spec. length
	120 x 32	-	-	-	590/spec. length
Delta-support	120 x 30	310	270	280	285/900/spec. length

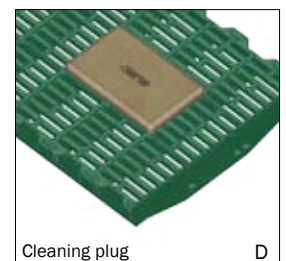
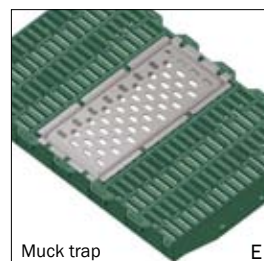
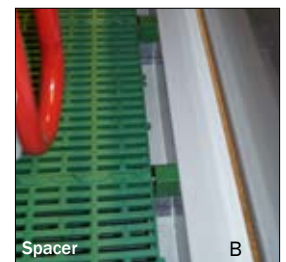
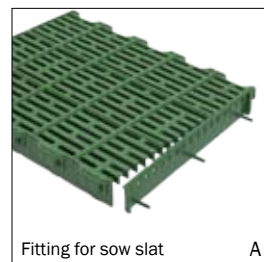

## ACCESSORIES

Article no.	Description	
17666	Fitting for slat 40 cm green	A
17667	Fitting for sow slat 40 cm green	-
8500301	Spacer for PVC floor 30 x 40 x 58,3 mm	B
09105	Filler for plastic slats	C
554164	Cleaning plug, polymer, f/plastic slat L21 x W13 x H7 cm	D
01777	Cleaning plug L13 x W10 x H15 cm	-
18169	Muck trap for farrowing pens, stainless steel, 38,5 x 18,5 cm	E
18083	Cross-section adapter for plastic slat, 20 cm	F

### ▲ ACCESSORIES FOR PLASTIC SLATS

- Good design
- Innovative solution
- Lower mounting costs
- Easy adjustment in length and width

# HEATING PLATES FOR FARROWING AND WEANER PENS

Heated with EL or water



## HEATING PLATES

The heating plate is used in farrowing pens to ensure optimal comfort for piglets and better survival ability during the first few days.

The heating plate requires only minimum maintenance, but at the same time ensures optimum growth conditions for even the smallest piglets. The bottom is provided with insulated foil material, so that the heat rises upwards.

EL-HEATING PLATES				
Description	Width x length, mm	Effect, W	Voltage, V	Max amount of plates to connect
El-heating plate, polymer concrete	400 x 1200	130	230	16
	500 x 1200	180		12
	800 x 1200	270		8
	500 x 1400	180		12
El-heating plate, plastic, rightward	400 x 1200	80		27
El-heating plate, plastic, leftward				

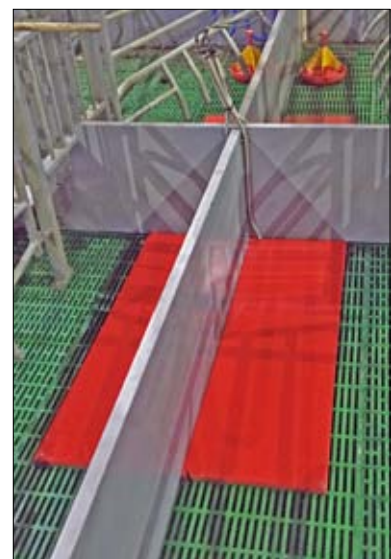
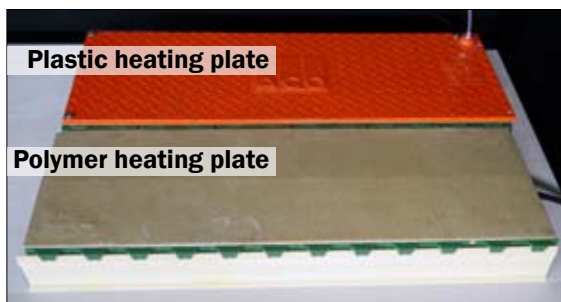

### Connection

There are molded electric heating trends in the polymer concrete in EL-heating plates, which makes the installation easy and cheap. It is possible to connect several plates in series, and with a relay the control unit can handle 2500W.

### ▲ CONTROL OF HEATING PLATES

The temperature of the electric heating plates is controlled via a "mother" heating plate. The temperature sensor cable in the heating plate is connected to the control panel/box, and the temperature is easily adjusted by pressing the buttons.

HOT WATER HEATING PLATES		
Description	Width x length, mm	Effect, W
Hot water heating plate in polymer concrete	400 x 1200	240
	500 x 1200	240
	600 x 1200	160
	800 x 1200	240
	500 x 1400	240

### Connection

In ACO FUNKI's heating plate for water, there are molded high-pressure pipes in polymer concrete with clamp fittings, which makes the installation easy and cheap. In this model it is possible to connect in series up to 5 units, where the temperature is regulated by one thermostat.



# HEATING PLATES FOR FARROWING AND WEANER PENS

Plates with optimal heat distribution

## ▼ COMPARISON OF PLASTIC AND POLYMER HOT WATER HEATING PLATES

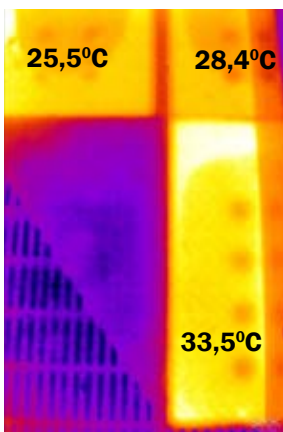
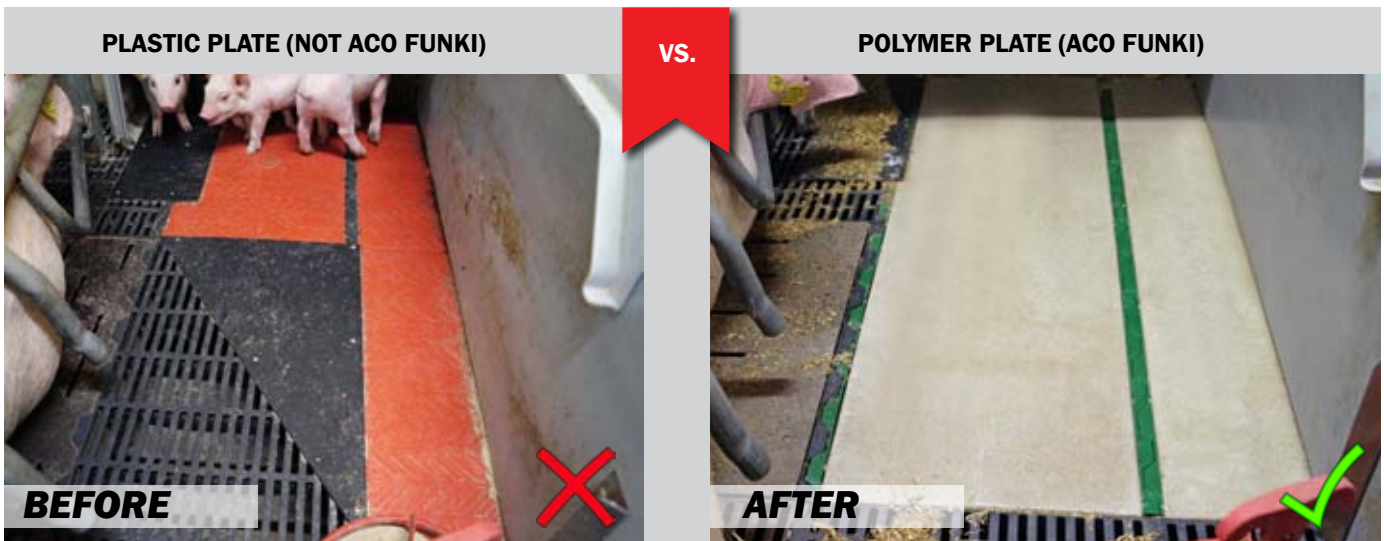

Thermographical heat distribution plastic heating plate

- Uneven heat distribution
- Keeps on heat for a shorter time compared to polymer plate
- The surface can become soft and moist over time
- Air might appear inside the plate
- Not isolated in the bottom
- Shorter lifetime compared to polymer plate

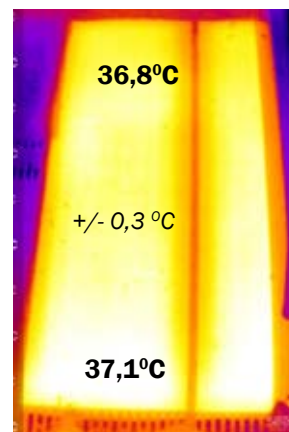

Thermographical heat distribution for polymer heating plate

- Even heat distribution
- Keeps on heat for a long time
- The surface continues to be dry, since water always runs out
- No air inside the plate
- Isolated in the bottom
- Long lifetime
- +5 degrees warmer compared to plastic plate



### Testimonials:

“ Karsten Kur Jensen has replaced plastic heating plates with the polymer heating plates in 576 farrowing pens. It has resulted in better micro-climate for piglets and higher production results: 41,2 psy.

“Now the piglets are lying in the piglet nest, and there is even heat distribution. At the same time, polymer plate gives more heat to piglets. After switching to polymer plates, the temperature in the piglet nest has increased by 5 degrees.”

Karsten Kur Jensen, Risgaarden, Viborg, Denmark  
2200 sows, 41,2 psy

# SELF-SUPPORTING CAST IRON SLATS

Flexibility and hygiene



## HEALTH CONDITIONS IN FOCUS

- Slightly rough surface makes the slat slip-resistant
- T-shaped ribs ensures optimum manure passage

## MINIMUM WORKING TIME CONSUMPTION

- Large cleaning opening
- Hard surface and minimum surface area

## ENVIRONMENT AND ECONOMY

- Long lifetime - good for both environment and economy
- Same bearing surface and height as triangle slats, that can easily be replaced
- Self-supporting = low mounting costs
- Small surface = low emission

TYPE OVERVIEW	
<b>FARROWING PENS</b>	<b>Dimensions, mm</b>
Beam: 10 mm Slot: 11 mm	800 x 400 x 30
	900 x 400 x 30
	1000 x 400 x 30
	1100 x 400 x 30
	1200 x 400 x 30
	1400 x 400 x 30
	1600 x 400 x 30
<b>WEANERS AND WEAN-TO-FINISH</b>	
Beam: 12 mm Slot: 13 mm	1200 x 400 x 30
	1400 x 400 x 30
	1600 x 400 x 30
	1800 x 400 x 30
	2000 x 400 x 30
<b>FINISHERS</b>	
Beam: 30 mm Slot: 15 mm Cleaning opening: 40 mm	1600 x 400 x 30

## ACCESSORIES

We have several types of covers and fittings for cast iron slats. Contact us for a complete overview and price list.



Our cast iron slats are specially designed to fit the cover rib. Easy mounting by means of allen wrench.

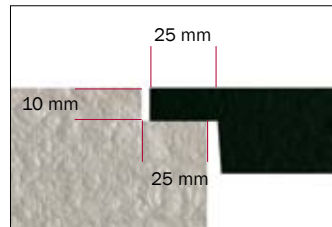

Cast iron slats have the same bearing surface and height as for ex. triangle slats, that can easily be replaced.





# STILL-CARE® RUBBER HEAT MAT

For use during farrowing - the best start for newborn piglets

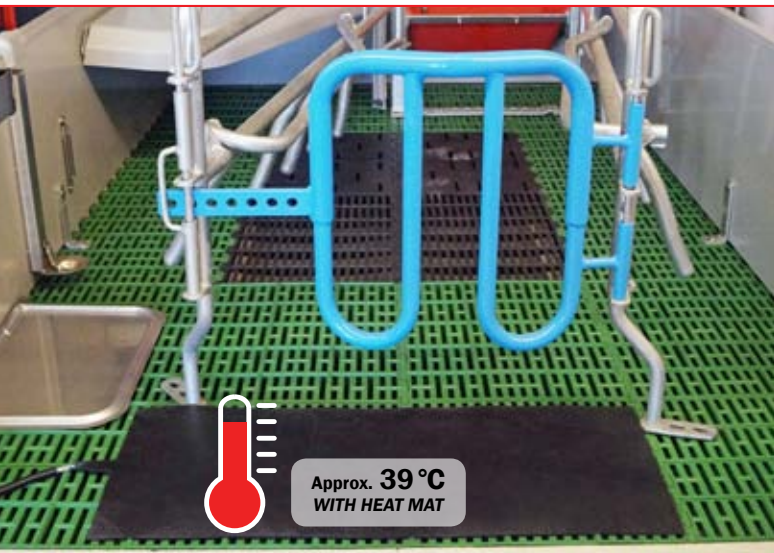

## THE BENEFITS OF STILL-CARE HEAT MAT

- Prevents undercooling
- 0,2 more live pigs per litter
- Healthier pigs that recover faster after farrowing
- Mobile and easy - can be placed and removed again
- Non-slip surface
- Easy to clean and disinfect

Still-Care is a heat mat, which is placed behind a sow during the farrowing, so the piglets are born to a mat that is approx. 39 °C warm. With the heat mat, the newborn piglets get more optimal life start, as the risk of undercooling is reduced. It is expected that the survival rate for newborn piglets will increase by 0,2 piglets per litter (based on the first statistical experience). After farrowing, remove the Still-Care mat.

### Facts about Still-Care heat mat:

- Electrical
- Connection: 220 V
- Dimension: approx. 350 x 850 x 8 mm
- Temperature: 39 °C
- 3,5 m cable (with bite-resistant coating)



### GREATER SURVIVAL CHANCES

Without the Still-Care mat, the very first bedding for the newborn piglets is down to about 11 °C. With the Still-Care mat it is approx. 39 °C; the piglets get a more gentle start to life, thus having greater survival chances.

## ▼ RUBBER MATS FOR PIGLET NEST

Alternatives to floor heating



- Alternative to floor heating
- Easy to maintain
- Comfortable climate
- Easy to mount on the slats
- Reversible "turtle" structure
- Sized that fit all our piglets nests

Article no.	Description
44112	Rubber mat for piglet nest 80 cm, reversible
44118	Rubber mat for piglet nest 90 cm, reversible
27000011	Insulating rubber mat 80 cm, left
27000012	Insulating rubber mat 80 cm, right
27000013	Insulating rubber mat 90 cm, left
27000014	Insulating rubber mat 90 cm, right

### ◀ RUBBER MATS PER RUNNING METER

The rubber mats are also available in whole rolls or per meter. Recommended for use in climate covers with FLEXCOVER. Can be adjusted in the longitudinal direction.

Article no.	Description
27000024	Rubber mat, width 1,2 m, length 30 m, price per roll
27000025	Rubber mat, width 1,2 m, price per meter



# WATER SUPPLY

Complete water supply

**WATER FILTER SYSTEM**



**SECTION PIPE SYSTEM**

32, 50, 63 mm



**MAIN WATER SUPPLY**  
50, 63, 90 mm

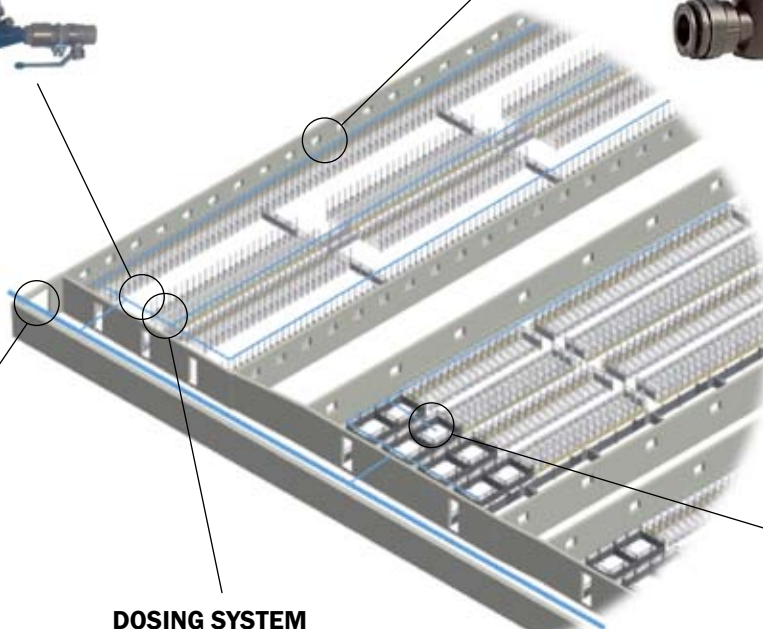

**DOSING SYSTEM**



**FLEXIBLE CONNECTION SYSTEM**

For hoses and pipes



## RELIABLE WATER SUPPLY

MASTER FLOW is a membrane-operated valve system, which maintains a constant water level in the trough.

The MASTER FLOW water level valve has two entrances with ½" internal threads for horizontal and vertical water pipes.

The water level valve is delivered with a plug in order to be able to close the entry not used.

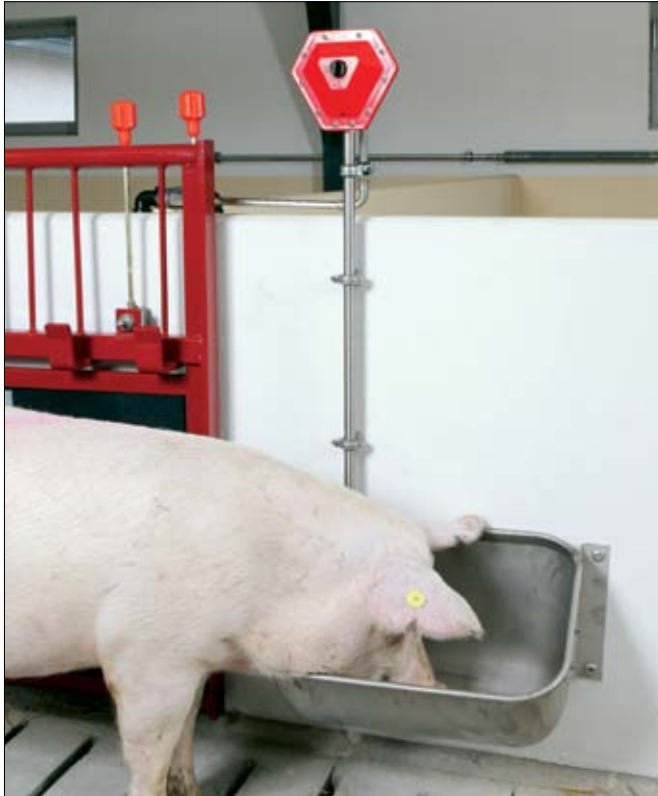

### For optimum use we recommend the following:

- Water supply with a prefilter
- Water pressure of 2,0 - 2,5 Bar/29 - 36 PSI
- The supply pipe - the vertical water pipe from the water level valve to the trough must be at least 80-200 cm
- The supply pipe should be placed as far from the feed outlet as possible
- Regular cleaning of the supply pipe in order to avoid water contamination

### WATER LEVEL VALVE

Article no.	Description	No. on picture
93469	MASTER FLOW incl. ½" plug	1
06902114	Water pipe ½", stainless steel, 1195 mm with 1 thread	2
06902115	Water pipe ½", stainless steel, 1495 cm with 1 thread	-
42220	Sow trough in stainless steel	3
96054	Stainless bracket for trough fastening. Incl. 4 stainless bolts for fastening to bracket and bolts for fastening on wall.	4
<b>Spare parts</b>		
93467	Membrane for MASTER FLOW	-
93465	Control button for MASTER FLOW	-

## ▼ TILTING TROUGH



▲ TILTING TROUGH FOR SOWS

◀ TILTING TROUGH FOR WEANERS

# SPRINKLING AND SOAKING

Dosing system - Additive system

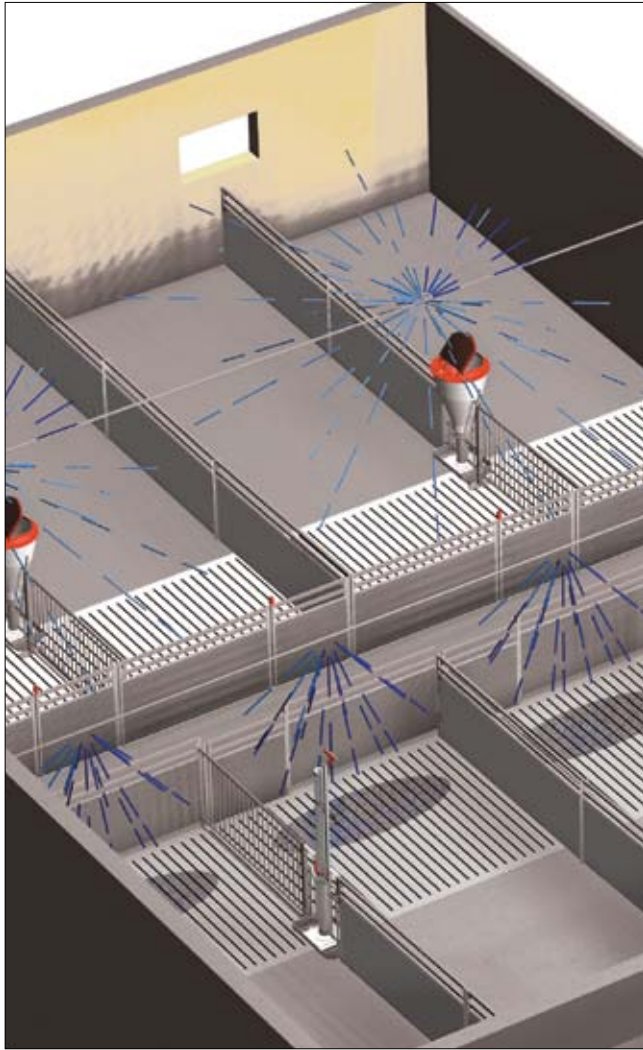

## WATER FILTER

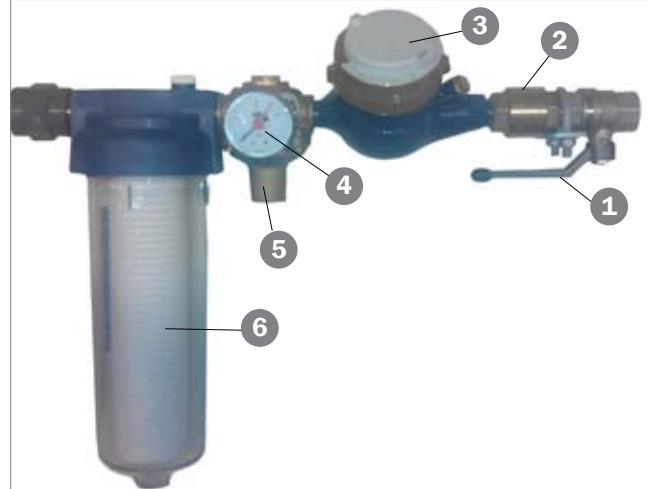

## WATER FILTER

No.	Description
1	Valve 3/4" with handle
2	Check valve 3/4"
3	Water meter 420 QN 1,5 DN15=1/2- 3/4 KLB 165 mm. 40 gr.
4	Pressure gauge 1/4"
5	Reducing valve 11BIS 3/4"
6	Water filter 3/4" sleeve
-	Filter 50 MY
-	Coupling 1/2 X 3/4
-	3/4" brass nipple pipe
-	Water filter set

## DOSING SYSTEM



## DOSING SYSTEM

No.	Description
1	Tee PVC 90° 32 mm TN16
2	Angle PVC 90° 32 mm TN16
-	Thread socket PVC 3/4" 32 mm int.
3	Ball valve PVC Ø32 mm, 1 X union
4	Pipe PVC w/glue socket 32 mm rm
-	Medicine mixer 0,2-2,0% inlet
-	Medicine mixer set

## ADDITIVE SYSTEM

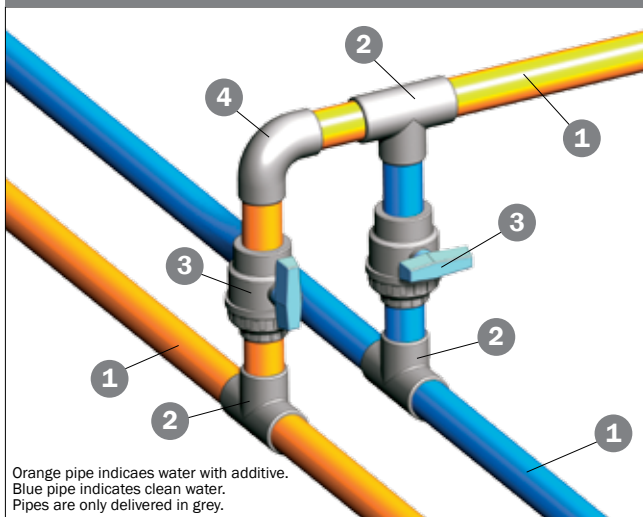

## ADDITIVE SYSTEM

No.	Description
1	Pipe PVC w/glue socket 32 mm r.m
2	T-piece PVC 90° 32 mm TN16
3	Ball valve, glue, 32 mm x 1 union
4	Angle PVC 90° 32 mm TN16

## NOZZLES

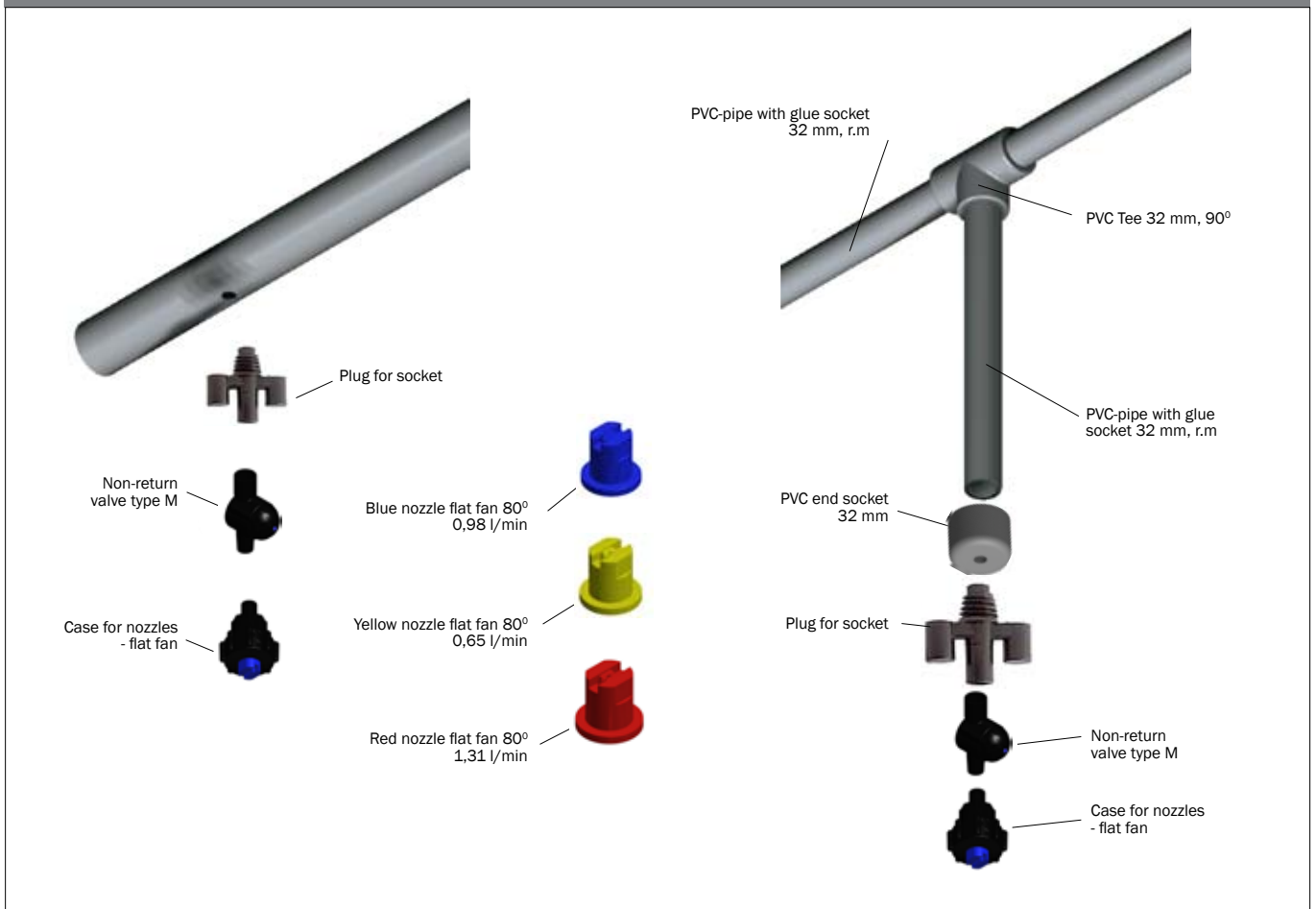

## DRINKING VALVES



### PRESSURE, BITE AND TILT VALVES

We can supply a wide range of water valves that meet the functional requirements for sows, finishers, weaners and piglets.

- Available with different threads to fit pipes of several sizes.
- The valves have different capacities to meet the requirements for water volumes
- We have of course the valves that fit our drinkers and feeders

*The valves are designed for pressure of 2.5 bar.*

### PRESSURE VALVES

Article no.	Description	Adjustable	L/min (at 2,5 bar)	Thread
281490	Pressure valve 3in1 SS	yes	4	½" int.
12100342	Pressure valve 3in1 SS type11	yes	4	½" int.
93305	Pressure valve SS	yes	4,5	½" int.

### TILT VALVES

Article no.	Description	Adjustable	L/min (at 2,5 bar)	Thread
93250	Tilt valve for DRIK-O-MAT	yes	4	½" ext.
560153	304 SS valve for drinking cup	yes	7	½" ext.
281496	Tilt valve for TUBE-O-MAT pipe	yes	4	½" ext.
93245	Tilt valve for TUBE-O-MAT	no	4	3/8" int.
9900047	Tilt valve SS type 17	no	7	½" int.
93280	Tilt valve sows 13	no	4	½" ext.
12100107	Drinking valve ½ SS type 13	yes	5	½" int.

### BITE VALVES - STAINLESS

Article no.	Description	Adjustable	L/min (at 2,5 bar)	Thread
9900053	Bite valve SS, weaners	yes	2,5	½" ext.
9900054	Bite valve SS, finishers	yes	4	½" ext.
93345	Bite valve SS, piglets	yes	1,5	3/8" ext.
9900058	Bite valve sows, brass	yes	6,5	½" ext.
93343	Bite valve sows, stainless	no	3	½" ext.



- Hygienic design
- Robust and durable
- Good water savings due to minimum water wastage
- Made of stainless steel
- Available in different sizes and designs that are specially adapted for weaners, finishers, sows and wean-to-finish
- Up to 30 pigs per drinking cup

# DRIK-O-MAT®

The original drinking cup



### The design of the DRIK-O-MAT® drinking cups gives a number of unique advantages

The heaviest thickness of material in the market and closed, bend edges guarantee a very strong drinking cup, which lasts for years. The bend edges also prevent dirt accumulation and injuries.

The rounded design ensures that there will be no blind corners and the closed design above prevents dung in the drinking cup and thereby it will always be clean. The water nipple is placed in the bottom of the drinking cup and releases only the amount of water that is actually drunk. This means considerable water savings and considerable reduction in the quantity of slurry.

DRIK-O-MAT® is delivered with a 23x2 mm water pipe with internal thread and bracket as well as with 1/2" adjustable drinking nipple in stainless steel.

### SPECIFICATIONS

Description	For	Pigs per cup	Mounting height
Mini DRIK-O-MAT®	Weaners	30	12 cm
Standard DRIK-O-MAT®	Finishers	30	25 cm
Multi DRIK-O-MAT®	Wean-to-Finish and sows	30 weaners	12 cm
		20 finishers	12 cm
		10 sows	35 cm
Maxi DRIK-O-MAT®	Sows	10	35 cm



# ACCESSORIES FOR FLOOR MOUNTING

Fittings

FOR PLASTIC SLATS	
Article no.	Description
30847	Anchor M8 plastic slats
90130847	Anchor M8 for plastic slats, big
30888	8 x 90 machine bolt (Torx 50)
30887	8 x 120 machine bolt (Torx 50)
30308071	Buttonhead stainless M8x70 w/o washer
1900241	Bolt-on fittings, 10 pcs.
17095	Slat anchor 8 mm, green (10 pcs.)
17128	Slat anchor 10 mm, green (10 pcs.)
18958	Slat anchor romb, weaner slat (10 pcs.)

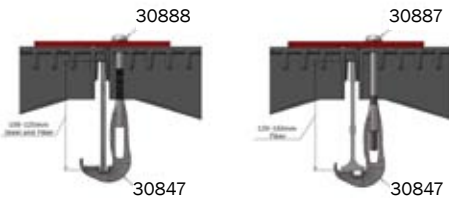

FOR CAST IRON SLATS	
Article no.	Description
1900241	Bolt-on fitting, 10 pcs.
96967	Bracket for mounting, 10 pcs.

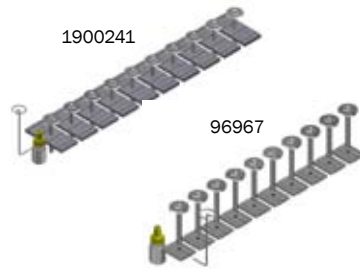

FOR CONCRETE / WALL	
Article no.	Description
39406050	Concrete screw 6,5 x 50 Torx 27
67442	Coach screw 10x100 mm Torx 50
67444	Coach screw 10x70 mm Torx 50
39900001	Wall plug 12x60



FOR CONCRETE SLATS	
Article no.	Description
30871	T-anchor 80-100 mm
30875	T-anchor 100-120 mm
30872	Buttonhead M10x90 Torx 50
90100079	50 mm displaced T-bolt
30310080	Buttonhead M10x80 Torx 50
90100078	T-bolt cast M10 SS
30878	Retaining tool for mounting

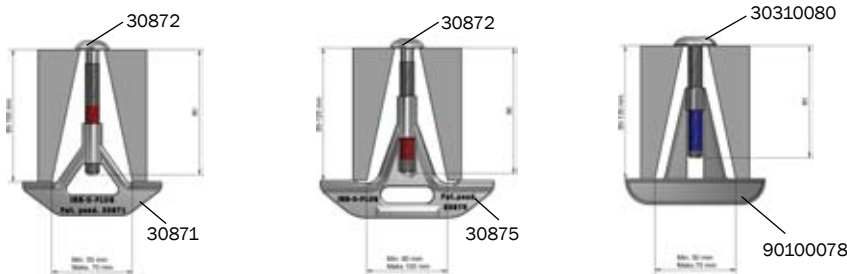

Tested to a pull of 1,9 Tons  
Tightened with 80 Nm

Tested to a pull of 1,8 Tons  
Tightened with 50 Nm

Tested to a pull of 2,3 Tons  
Tightened with 100 Nm



INN-O-PLUG for slatted floor	
Article no.	Description
30873	INN-O-PLUG set, slat anchor 80-100 mm incl. screw
30882	INN-O-PLUG set, slat anchor 100-120 mm incl. screw
480020	T-bolt for concrete slats, 10 pcs.
96967	Fitting for mounting of equipment on cast iron slats, 10 pcs.

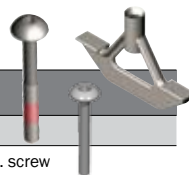

INN-O-PLUG for plastic slats	
Article no.	Description
30847	Anchor, SS, for mounting of plastic slats on support iron
30888	8 x 90 machine bolt (torx 50) for fibre glass support
30887	8 x 120 machine bolt (torx 50) for fibre glass support
30308071	Buttonhead M8x70 without washer TORX 50
30130487	Anchor M8, large



INN-O-PLUG for PVC board profiles	
Article no.	Description
39106020	6 x 18 screw internal torx, stainless
39206037	8 x 37 insex pipe nut, stainless
4900466	Connecting screw set 39-48 mm, stainless
4900467	Connecting screw set 44-58 mm, stainless
4900468	Connecting screw set 49-68 mm, stainless



RETAINING TOOL	
Article no.	Description
30878	Retaining tool for mounting of slat anchors

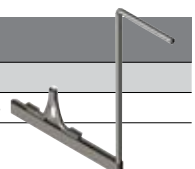



# GALVANIZED SILO

Environmentally friendly silo of recyclable material

## Excellent feed flow

- Obstruction-free hopper plates with smooth protective internal coating.

## Wide range of capacities and features

- Four different diameters with volumes from 3.9 m<sup>3</sup> to 49.8 m<sup>3</sup>
- Unique range of day bins from 0.5 m<sup>3</sup> to 2.5 m<sup>3</sup>
- Bins for pneumatic or mechanical filling

## Options available

- Safety platform
- Solid construction. It complies with the German DIN standard (DIN18194)

## Keeps feed fresh and nutritious

- Heavy galvanization and corrugated sheets reduce temperature fluctuations inside the bin

## Durable and maintenance friendly

- Encapsulated external bolts to prevent corrosion
- 5 year warranty against perforation by corrosion!
- Environmentally friendly – material can be recycled after use



## ▲ FILLING SYSTEM

mechanical, pneumatic or mechanical/pneumatical



## ▲ BIN WEIGHING



## ▲ PLASTIFIED BOLTS





# FIBRE GLASS SILO

Silo with good ability for thermal insulation



## ◀ Suitable for cold climates

The fiberglass silos of ACO FUNKI are synonymous with lightness combined with high resistance to environmental extremes, high tenacity and great thermal insulation.

Fiberglass silos are very durable, they do not rust and they do not require special maintenance. Moreover, they can be supplied as one-piece (monolithic) silos or as horizontally or vertically split silos. All of them grant an easy check of the product level through a transparent strip located in the body.

Model	Legs	Volume		DIMENSIONS					
		m <sup>3</sup>	Ton	A	B	C	D	E	F
AF04	3	4,0	2,4	3720	1050	250	1600	2500	1530
AF06	3	6,0	3,6	4190	1050	300	2000	2500	1870
AF08	3	8,0	4,8	4780	1050	300	2000	2500	1870
AF10	3	10,0	6,0	5080	1050	300	2200	2800	2045
AF12	3	12,0	7,2	5620	1050	300	2200	2800	2045
AF15	4	15,0	9,0	5980	1050	300	2400	3000	2230
AF18	4	18,0	10,8	6650	1050	300	2400	3000	1815
AF20	4	20,0	12,0	6900	1050	300	2470	3000	1885
AF26	4	26,0	15,0	7620	1050	400	2600	3000	1975
AF31	4	31,0	18,6	8800	1050	400	2600	3000	1970
AF40	4	40,0	24,0	8450	1050	500	3000	3500	2260
AF52	4	52,0	31,2	10010	1050	500	3000	3500	2260
AF66	4	66,0	39,6	12010	1050	600	3000	3500	2260

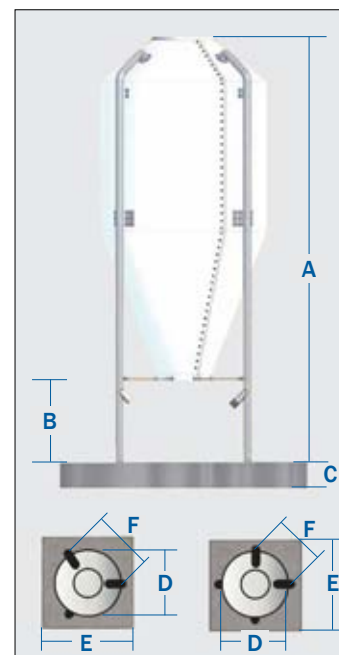

# WASH ROBOT FOR PIG HOUSES

Powerful, flexible and reliable

## ◀ PROCLEANER X100

ProCleaner X100 can be programmed to run both a soaking programme and several different types of wash. The robot is controlled electronically and connected via the existing high-pressure system. Wash time for 30 m of pig house, 5 m depth is 3-4 hours.



WASH ROBOT	
<b>Dimensions (L x W x H)</b>	115 x 69 (w/o side wheels) x 145 cm
<b>Weight</b>	285 kg
<b>Power supply</b>	230 V
<b>Water consumption</b>	20-40 L/min
<b>Operating pressure</b>	140 bar
<b>Max water pressure</b>	200 bar

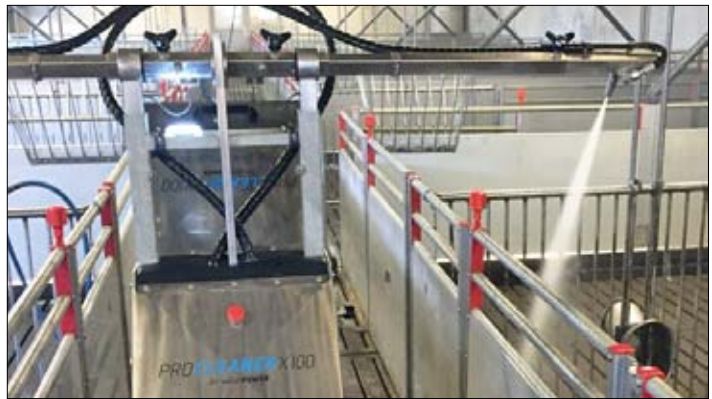

# AKTIVA WAGON

Carcass wagon for pork and heavy pigs



## FOR FINISHERS

<b>Width</b>	60 cm
<b>Height</b>	175 cm
<b>Weight</b>	45 kg
<b>Length floor level</b>	93 cm
<b>Length in height</b>	111 cm

- Max. load: 600 kg.
- Pull: 800 kg.
- Heavy rubber wheel with 4 layers of canvas.
- Steel rims with needle bearing.

## FOR SOWS

<b>Width</b>	60 cm
<b>Height</b>	185/198 cm
<b>Weight</b>	50 kg
<b>Length floor level</b>	110 cm
<b>Length in height</b>	133 cm

- Max. load: 600 kg.
- 6 mm rope with a tensile strength 2300 kg.
- Automatic holding break: holds loads in any given position.
- Air-filled with 4 ply vulcanised rubber wheel.

## ▲ CARCASS WAGON FOR PIGS

AKTIVA wagon is available in two models: AKTIVA 2002 for finishers and AKTIVA 3002 for sows. The wagon is produced in Denmark and made of strong PA6-plastic and stainless steel. The pipe frame is hot galvanized for extra durability.

# ACO FUNKI PROTECT

Extends the lifetime of your concrete floor

► **ACO FUNKI PROTECT**  
protect the concrete slats and concrete surfaces so the lifetime increases.

ACO FUNKI PROTECT BASIS penetrates approx. 1 cm in the concrete and reacts with the free calcium molecules. This produces a stable acid-resistant structure of the concrete, which protect against acid corrosion.

The subsequent treatment with ACO FUNKI PROTECT TOP ensures that the concrete surface is permanently resistant, waterproof and acid-resistant.

The water absorption of concrete is reduced to an absolute minimum.

Solidifies deep into the concrete and closes the pores so the concrete is reinforced and is chemically resistant to acid attack.



**ACO FUNKI PROTECT used particularly in the following areas:**

- On concrete slats
- Below drinking cups
- Around feeders
- Around feeding troughs
- Feed tiles in cattle stables
- Around feed silos
- Floors in poultry houses
- Applies to both old and new concrete floor



◀ Untreated after 3 years use - acid-attack is started.

► ACO FUNKI PROTECT treated after 3 years use - no acid-attack.



# ACO FUNKI

Visit our showroom

ACO FUNKI's Showroom is located in Herning, Denmark, where you can find different kinds of penning equipment as well as our solutions for dry and liquid feeding, drinking and flooring systems, components and much more.

Without any commitment you can see, feel and try out the differences and thereby choose the solution that matches exactly your needs.



Contact us and make an appointment: (+45) 9711 9600

## SERVICE AND MOUNTING

Service - Mounting - Spare parts



ACO FUNKI has its own service center in Denmark. Our service technicians have more than 15 years of experience in the field and are ready to help you with mounting and technical guidance.



- International service
- Mounting of new stables
- Renovation of existing facilities
- Emergency service assistance in case of breakdown
- Sale of spare parts
- Sale of renovations and minor extensions

CONTACT SERVICE AND MOUNTING: (+45) 9711 8500



DESIGN

GENETICS

FEEDING &  
GRAIN  
STORAGE

FINANCES

HOUSING  
TECHNOLOGY

SLURRY  
SYSTEM

EDUCATION &  
MANAGEMENT

GREEN  
ENVIRONMENT

**VISIT US AND  
LEARN MORE!**



# DANISH PIG ACADEMY

## Complete farm solutions



ACO FUNKI is a member of Danish Pig Academy - a collaboration of independent Danish companies within equipment and services for pig production. The Danish Pig Academy is a gathering point for both international and Danish pig producers as well as other interested persons, groups, institutions and organizations within the pig industry.

At Danish Pig Academy, you will meet the leading Danish companies, excelling within the field of modern pig farming. The Danish Pig Academy has established the unique showroom in Denmark full of professional equipment and inspirational environment. We have everything you need for your professional pig farm. All at one place!

### 40 PIGLETS PER SOW PER YEAR

**Get inspiration and build the most profitable pig farm**

We offer you the best of Danish technologies, so that you can achieve the best results.

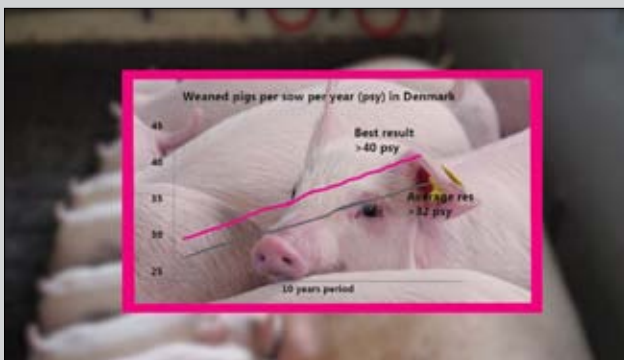

*Production results for the top-leading Danish farms*



[www.danishpigacademy.com](http://www.danishpigacademy.com)

biosecurity – breeding – conveyor systems – courses and training – dry feeding farm management – feed heating  
insemination – IT solutions liquid feeding – nutrition and supplements – penning – silos  
slats & flooring – slurry system – farm design – buildings – ventilation – wash robots

[www.acofunki.com](http://www.acofunki.com) | T. +45 9711 9600

# MATERIAL SOLUTION

We place great emphasis on the relevant and optimal selection of materials for every project. Our many years' experience of the harsh environments that equipment and feeding systems are often exposed to means that we are able to offer highly durable, yet competitive solutions.

The table below shows the materials and surface treatments that we normally use.

## HOT DIP GALVANISATION

Hot dip galvanisation is a zinc-based surface treatment. Hot dip galvanisation provides good protection against corrosion in most environments and thus a long life. Hot dip galvanisation provides high resistance to mechanical wear, while the zinc provides cathodic protection against corrosion.

Galvanisation methods and standards are carried out in accordance with DS/EN 1461 ISO 2009 (available on request. Please contact us).

## POWDER COATING

We offer selected equipment and equipment with a powder-coated finish for use in places where it is appropriate for reasons of animal welfare and working functionality.

MATERIALS	DESCRIPTION	PROPERTIES AND USE
<b>Stainless steel</b>	WST no. 1.4301 (A304)  WST nr. 1.4509	For example, water pipes. Corrosion resistant. Smooth. A particularly easy-to-clean surface. Withstands normal mains water with a chloride content of up to 75 PPM. For values higher than this, details regarding the water quality should be given for a special offer, possibly based on alternative choice of material. For example, U-profiles, troughs. A particularly easy-to-clean surface.
<b>Iron - steel</b>	Steel 37-2	For example, pipes, square profiles, sheet, flat iron, angle iron and round iron etc.
<b>Cast iron</b>	GGG40. Spheroidal graphite	For cast iron slats. May be subject to galvanic corrosion. An intermediate coating of plastic is therefore always used between slats and foot brackets on equipment.
<b>PVC</b>	Surface 100% new lead-free PVC. Nuance differences may occur	For example, panels, U-profiles and floor profiles for CLEAN-O-FLEX® and covering (2-climate). Fittings and pipes. PVC is an extremely strong material that withstands repeated heavy exposure without impaired durability.
<b>LDPE</b>	Low Density Polyethylene black plate 10 and 12 mm	For example, plastic plates and in INN-O-FLEX® equipment. LDPE is impact-resistant with a high resistance to many solvents.
<b>EPP</b>	Expanded polypropylene is an engineered plastic foam material, suitable for items with wall thickness more than 5 mm	For example, creep boxes (INN-O-CORNER). EPP provides high impact-resistant and a smooth, easy-to-clean surface that withstands washing with a high-pressure cleaner.
SURFACE	DESCRIPTION	PROPERTIES AND USE
<b>Hot dip galvanisation</b>	Layer thickness 30-180 µm depending on thickness of metal. High thickness gives a thicker layer. Standard DS/EN 1461 ISO 2009	For example, pipes, sheet and profiles. Corrosive attacks are prevented as long as the surface is intact. May be corroded by ammonia. Sharp edges may occur. Slightly rough surface - not easy to clean.
<b>Powder coating</b>	Caking of polymere powder. Layer thickness = approx. 80-100 µm	For selected equipment where appropriate for reasons of animal welfare and working functionality.
<b>Electro-galvanisation</b>	Sendzimir galvanisation. Layer thickness = approx. 17 µm on hoop steel. Approx. 10 µm on screws and bolts.	For feed pipes. In particularly harsh environments or where an extra durability is required, stainless steel feed tubes and corners are recommended.

# ACO WORLD

## STRONG CORPORATE SUPPORT



ACO FUNKI is a part of ACO Group, a world market leader in drainage technology. With its integrated approach, ACO stands for professional drainage, efficient cleaning, and the controlled discharge or reuse of water. ACO Group is built on intense research and development, and its technical expertise in processing polymer concrete, plastic, cast iron, stainless steel and reinforced concrete.



ACO is present in over 40 countries, with a total of 30 production sites on four continents. With a global workforce of 4,800, the company generated sales of Euro 775 million in 2017.

As part of ACO Group, we have the opportunity to manufacture our products at ACO's own production facilities located in 15 countries, often even close to the end user in order to offer the most competitive price.

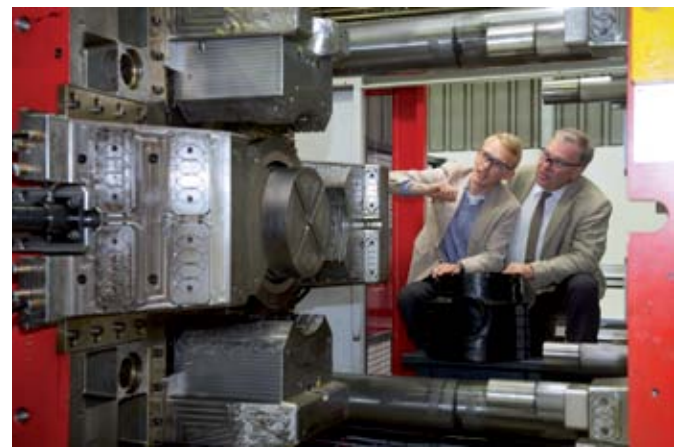

A team of highly qualified specialists in Denmark constantly works on the development and optimization of our products, before they are released for production in different parts of the world.

The ACO FUNKI factory in Denmark produces stainless steel troughs, posts for penning equipment and the renowned PowerLine chain for dry feeding. The same applies for electronic process controls and management systems as well as the assembling of feeders, penning equipment and power units for dry feeding.

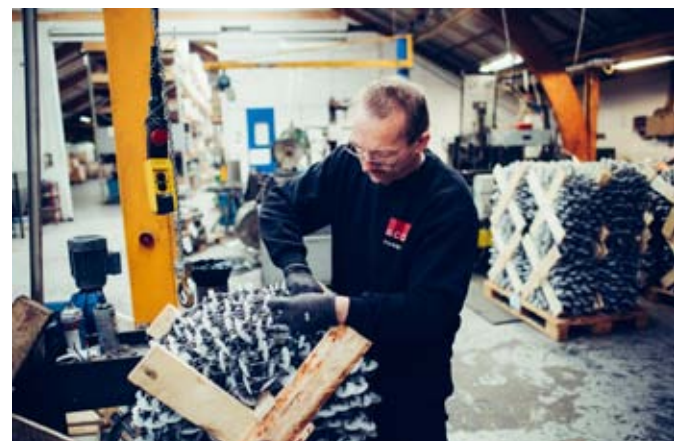

We are proud to produce and deliver high-quality products - anywhere in the world.



**FUNKI**



**NO COMPROMISE**

**DENMARK - HQ**

Kirkevænget 5  
DK-7400 Herning  
T. +45 97119600  
F. +45 97119677  
acofunki@acofunki.dk

**GERMANY**

Vorwerksallee 14  
24782 Büdelsdorf  
T. +49 43316649711  
F. +49 43314378912  
info@aco-funki.de

**SPAIN**

Cr. Major 52, 1r 1a  
E-08110 Montcada  
i Reixac (Barcelona)  
T. +34 935 650727  
F. +34 935 753678  
fclosa@acofunki.com

**FRANCE**

Parc d'innovation  
de Mescoat  
F-29800 Landerneau  
T. +33 298 303685  
F. +33 298 215506  
info.fr@acofunki.com

**RUSSIA**

Kalinina street 1  
396116  
Verhnyaya Hava,  
Voronezh region  
T. +45 962 69242  
T. +7 915 5456712  
mila@acofunki.dk

**CHINA**

上海市松江区华加  
路99  
号华滨工业园  
24栋厂房 201611  
+86 02157749818-  
400  
jshang@aco.cn

**UKRAINE**

ACO FUNKI LLC  
ACO Industries  
Shevchenka str.73  
Kulykiv,  
80362 Zhovka  
Livi region