



FUNKI MULTISTRAW

Automatic distribution of straw



- Recommended for all animal groups
- Reduces straw consumption by up to 80%
- Capacity from 0,5 to 10 l
- Automatic distribution of straw
- Allocation of straw several times a day
- Can adjust the amount per pen
- Improves animals' welfare
- Improves stomach health
- Reduced medicine consumption
- Improved working environment
- Can increase dry substance in the slurry for efficient biogas production



DANISH DESIGN | GERMAN QUALITY | GLOBAL EXPERIENCE



| FUNKI MULTISTRAW SYSTEM |

Automatic distribution of straw for all age groups

Funki MultiStraw transports cut straw by means of the special transport system, controlled by Funki MultiController.

Along with the straw dosing units, this provides a system that can distribute straw at the desired times and amounts during the day.

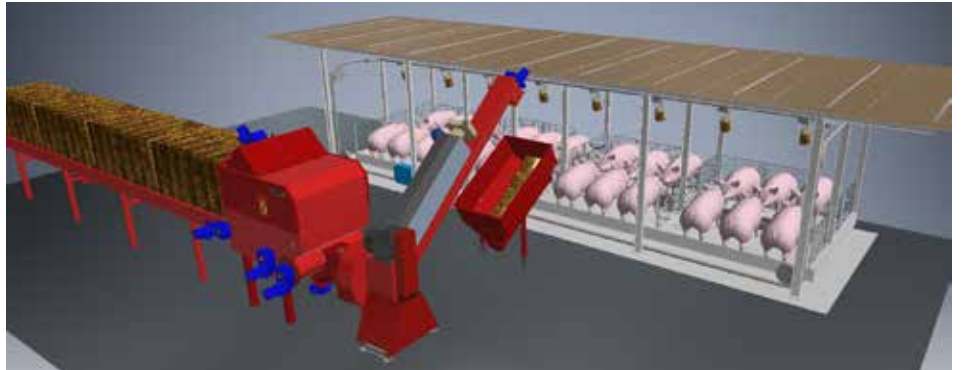

Funki MultiStraw can dose the exact amount of straw needed by the individual animal groups. The amount of straw can be adjusted to the animals' needs. By increasing the amount of straw, biogas production can be improved as the amount of dry substance in the slurry is increased.

Likewise, it is possible to adjust the dosing times so that it happens outside of the times when the employees are in the stable, which provides a better working environment.

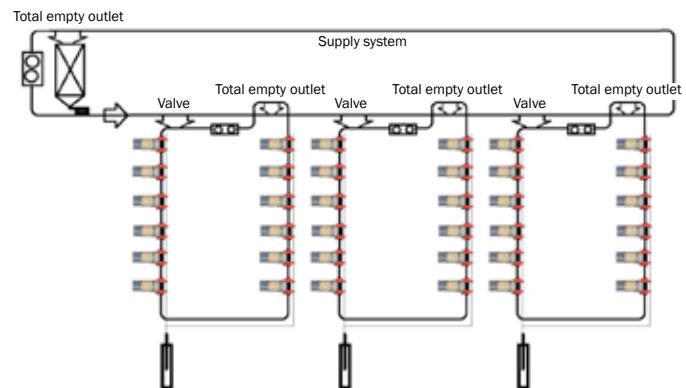

- Straw humidity of max 14%
- Straw up to 4 cm
- Dosing unit capacity is 3-8 m³
- No bridging
- Possibility of tearing equipment
- Special Powerline chain for transportation of straw



Subject to changes in materials and design is reserved.

B-8035-GB

ACO FUNKI A/S
Kirkevænget 5
DK-7400 Herning
T. +45 9711 9600
www.acofunki.com

