

MOUNTING INSTRUCTION



LIQUID FEEDING TANK

RESIDUAL TANKS (2300, 4200, 6000 L)



ACO FUNKI A/S
Kirkevænget 5
DK-7400 Herning

Tel. +45 9711 9600
Fax +45 9711 9677
www.acofunki.com

DANISH DESIGN | GERMAN QUALITY | GLOBAL EXPERIENCE

MOUNTING INSTRUCTION FOR RESIDUAL TANK FOR LIQUID FEEDING

This mounting instruction contains information about how to assemble and install the residual tanks used for liquid feeding. Accessories for the tanks (e.g. acid evaporator, bacteria preventing UV-light and rotating high pressure cleaner) are described in separate instructions.

Mounting instructions for mixing tanks and water tanks are also found separately.

Water tanks, sizes	4
Overview of the tank	5
Mounting of “dummy” load cells	6
Positioning of the tank	6
Levelling the tank	6
Mounting of outlet connection	7
Mounting of inspection cap	7
Mounting of steps inside the tank	7
Mounting of bottom counter agitator	8
Mounting of counter agitator	8
Assembling the fiberglass parts	9
Mounting the hatch	9
Placing the warning signs	10
Overview of the stirrer	11
Mounting of gear motor	12
Mounting of shaft for stirrer	12
Mounting of bottom agitator	13
Mounting of split bearing bush	14
Mounting of middle agitator	16
Pipe for connecting the pump	17
Pipe for intake of liquid components	17
Pipe for intake of dry components	17
Return pipes	18
Pipe for ventilation of the tank	18
Mounting of level tilting device	18
Safety Switch	19
Internal washing of the tank, manually	19
Disassembly	19
Appendix: Service and maintenance of gear motor	20
Bill of materials	22

RESIDUAL TANKS - SIZES

RESIDUAL TANKS

The residual tanks for liquid feed comes in three sizes with a capacity of 2300, 4200 og 6000 L.

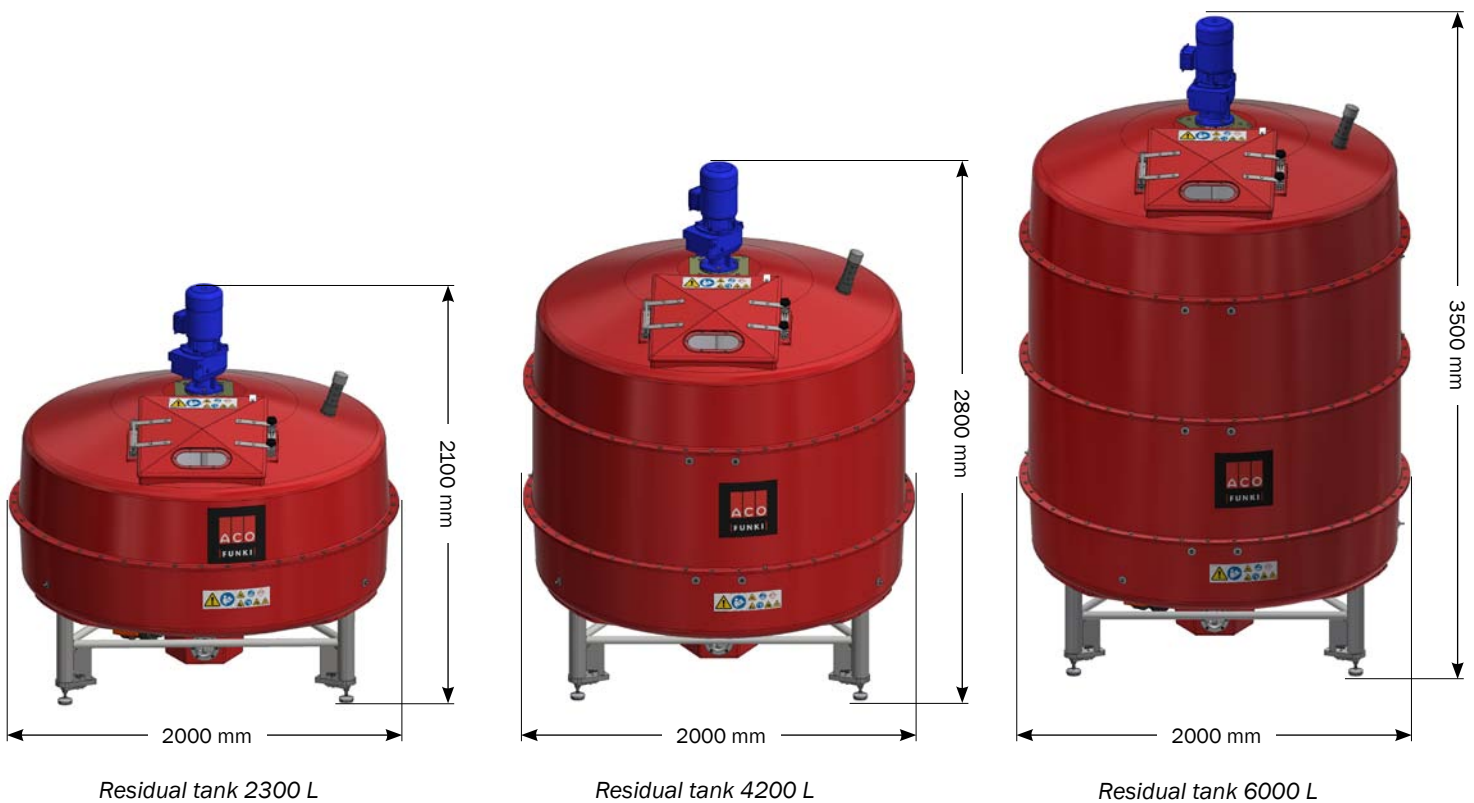

1. Stirrer and gear motor (see section about mounting the stirrer)
2. Ventilation
3. Hatch
4. Level tilting device
5. Counter agitators
6. Steps
7. Bottom agitators
8. Feet
9. Inspection cap
10. Outlet connection and ball valve
11. Bottom part of the tank (for the fiberglass container)
12. Fiberglass container, rings (number of rings depends on the size of the tank (0-2 pcs.))
13. Fiberglass container, top part

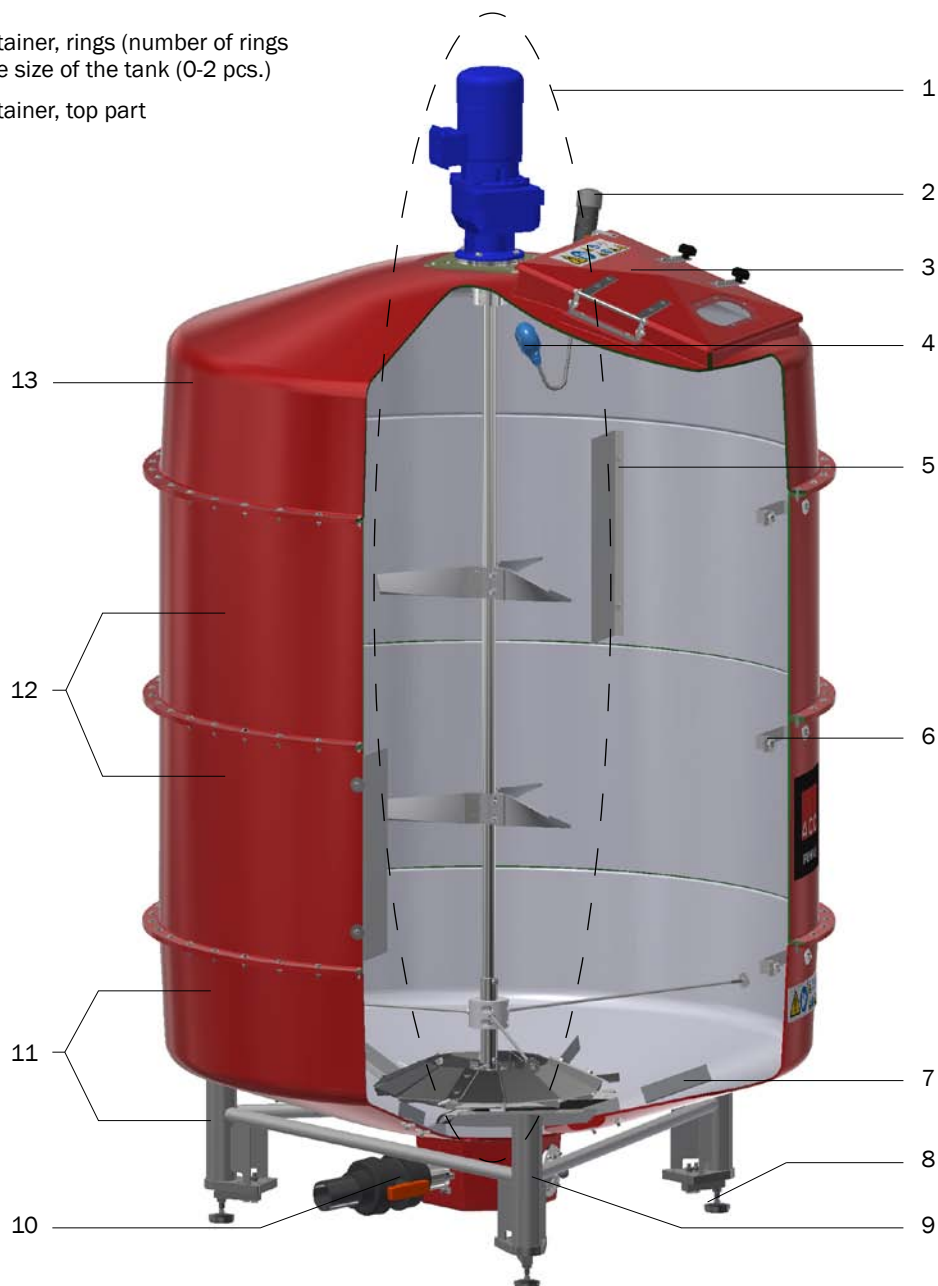

MOUNTING INSTRUCTION - RESIDUAL TANK

MOUNTING “DUMMY LOAD CELLS”

Load cells are not necessary for the residual tanks. Instead, “dummy load cells” are mounted. The “dummy load cells” are square pieces of steel that is mounted underneath the feet of the tank.

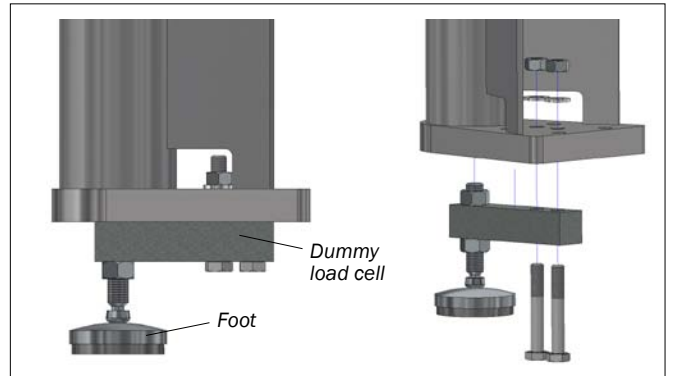

Mounting of “dummy load cells”

LOAD CELL DUMMY KIT			
	Item no.	Description	PCS.
	0139-506	LOAD CELLS MANIKIN KIT VF4	
1	0139-444	MACHINE SHOE TYPE HJ-7C DSI	1
2	32900015	MACHINE SCREW M12X80 FZB QUAL. 10.9 DIN 931	2
3	33900028	NUT M12 A4-80 DIN 934	2
4	35600080	FLAT WASHER Ø12X13/24/2,5 A2 DIN 125 A	2
5	0139-577	LOAD CELL DUMMY DT540 M16	1

POSITIONING OF THE TANK

The bottom part of the tank is placed on the floor. The floor should be approximately level.

Be sure to notice how the bottom part is placed in relation to the pump and outlet.

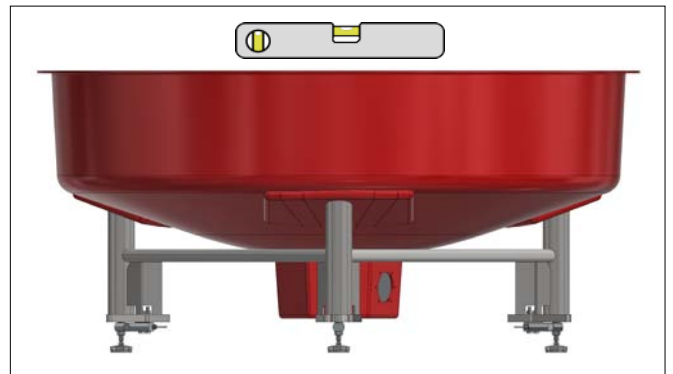

Bottom part of tank with feet

LEVELING THE TANK

Under each “dummy load cell” the height can be adjusted by approx. 20 mm. Adjust the height so that the feet are leveled horizontally. Do not raise the height of the feet more than necessary (because of the stability).

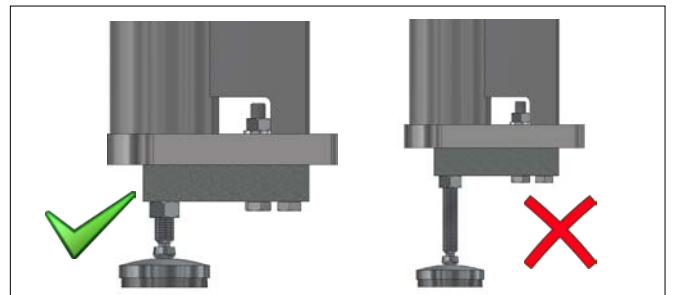

Adjusting the feet

MOUNTING OF OUTLET CONNECTION

The outlet connection is placed in the bottom of the tank (see the overview illustration).

Apply two whole circles of sealants around the neck of the outlet connection and around the welded screws.

The outlet connection (with applied sealants) is mounted from the inside of the tank in one of the two pre-made holes (see ill.)

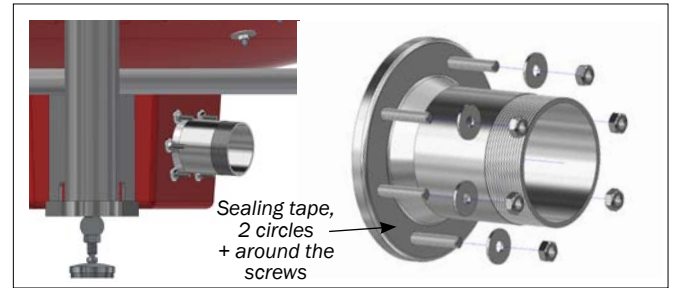

Mounting of outlet

MOUNTING OF INSPECTION CAP

The inspection cap is placed in the bottom of the tank opposite the outlet connection (see overview illustration).

Apply two whole circles of sealants around the neck of the inspection cap and around the welded screws.

The flange (with applied sealants) is mounted from the inside of the tank in the other of the two pre-made holes (see ill.).

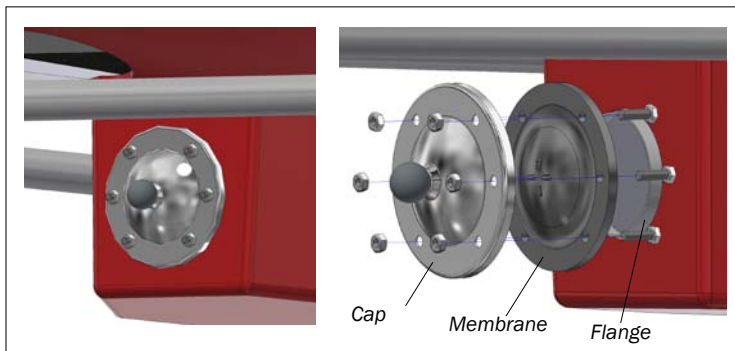

Inspection cap

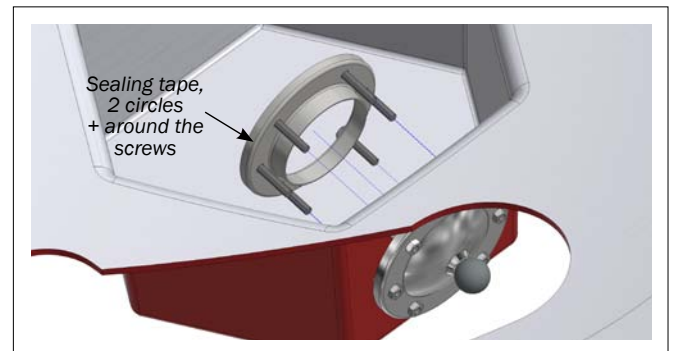

Inspection cap, sealing tape on the inside

MOUNTING OF STEPS INSIDE OF THE TANK

Steps are mounted on the inside of the tanks. 1 step is mounted per fiberglass ring joint - i.e. 2-5 pcs. depending of the size of the tank. Mount the steps on the rings before assembling the rings.

Use the steps as drill templates. Remember to seal with sealing tape (see ill.).

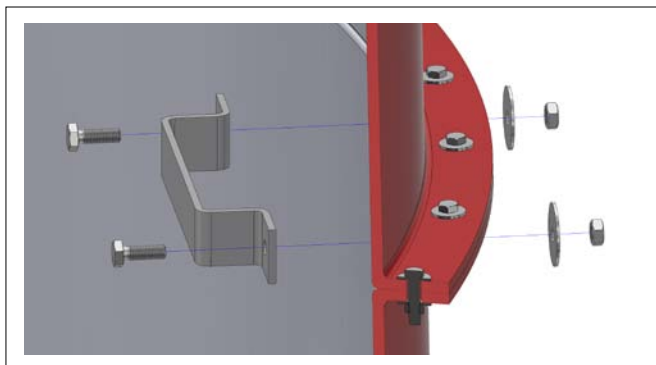

Steps inside the tank

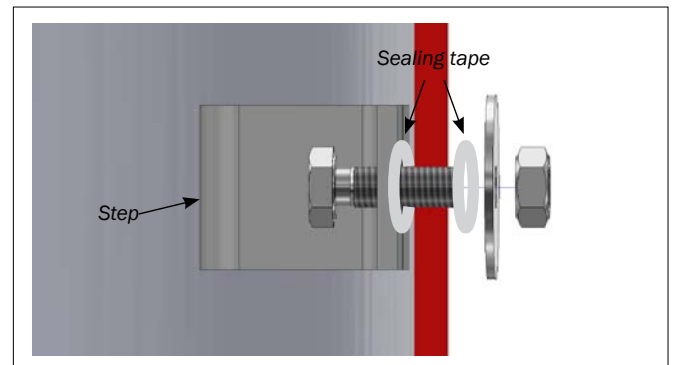

Sealing tape inside and outside the tank

MOUNTING OF BOTTOM COUNTER AGITATORS (6 PCS.)

The bottom counter agitators are placed radially to the stirrer (see ill.). Be aware of the embedded legs in the bottom of the tank when placing the bottom counter agitators.

The bottom counter agitators are used as drill templates for two Ø11 mm holes per bottom counter agitator. Remember sealing tape (see ill.).

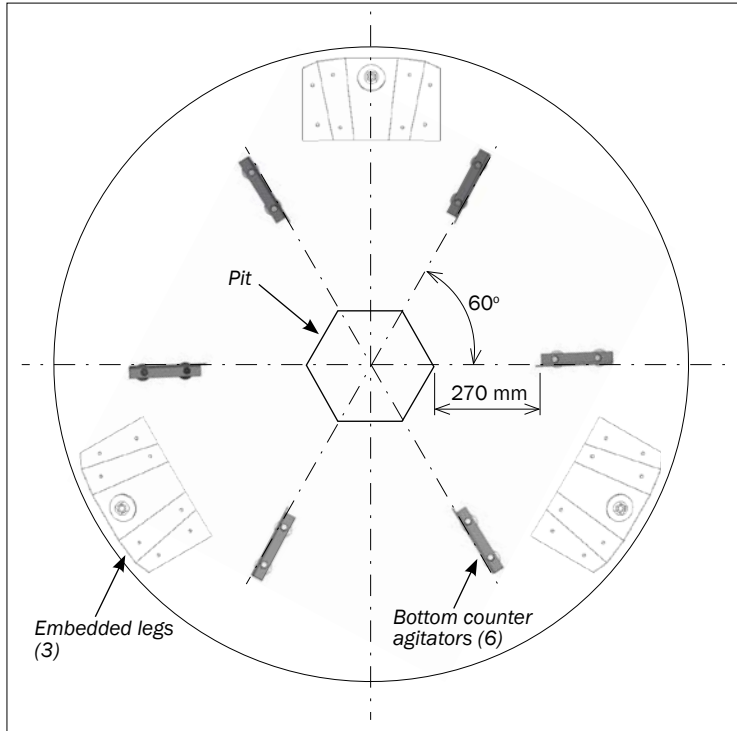

Placing of the bottom counter agitators

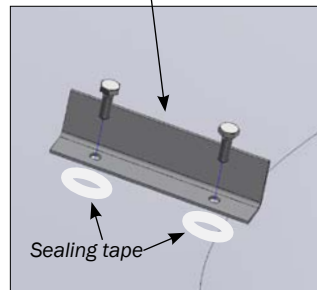
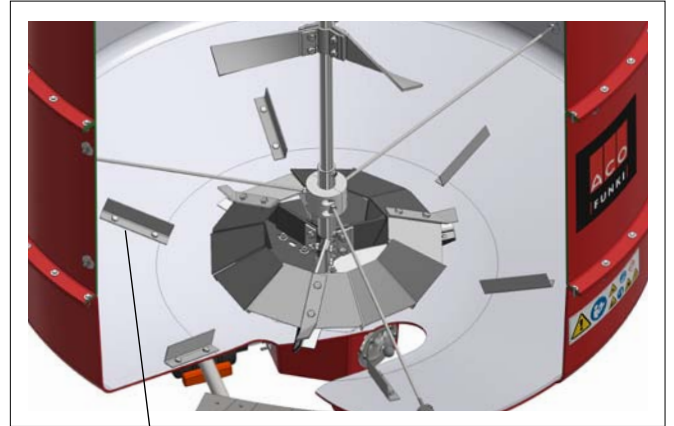

Bottom counter agitator, inside

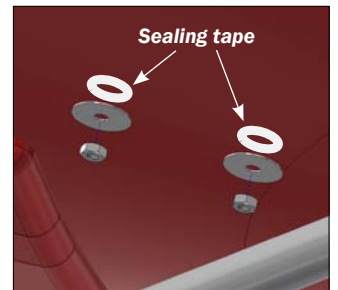

Bottom counter agitator, outside

MOUNTING OF COUNTER AGITATOR

One counter agitator is mounted per fiberglass part of the tank:

2300 L	-	0 counter agitators
4200 L	-	1 counter agitator
6000 L	-	2 counter agitators

Mount the counter agitators on the rings before assembling the rings.

The counter agitators are placed vertically in the side of the tank, and horizontally in the middle of the ring. When mounting more than one counter agitator, place them alternately opposite each other (see ill.).

Use one of the counter agitators as a template for drilling two holes for each counter agitator. Remember sealing tape (see ill.).

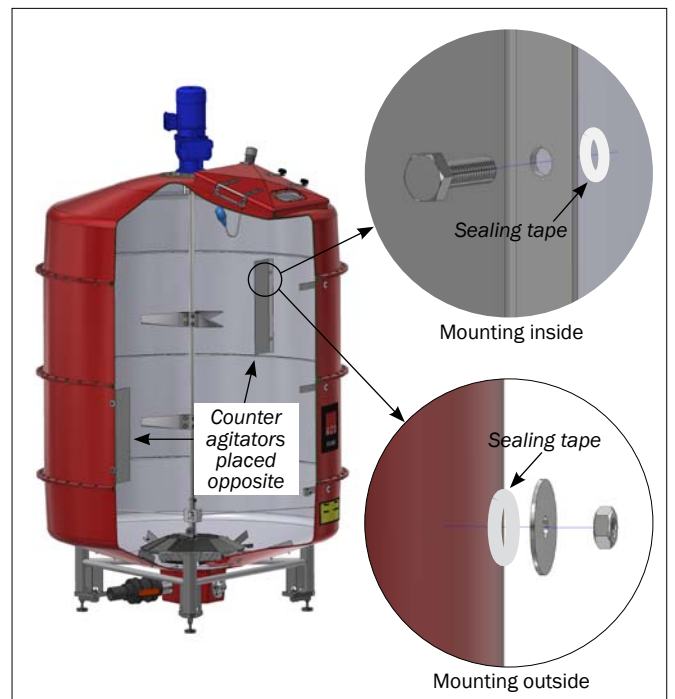

Placing the counter agitators

ASSEMBLING THE FIBERGLASS PARTS

Apply two whole circles of sealants around the flange. Assemble the parts flange to flange. Position the upper part so that the hatch is placed so that it is easy to access it. The tank parts are fastened as shown.

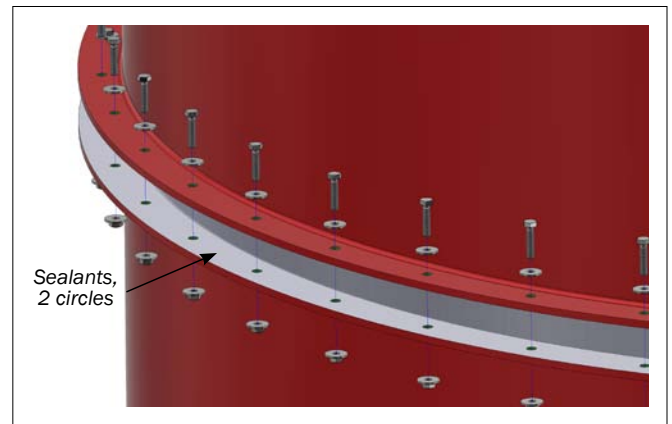

Assembling the fiberglass parts

MOUNTING OF THE HATCH

The hatch is pre-assembled and mounted on the tank.

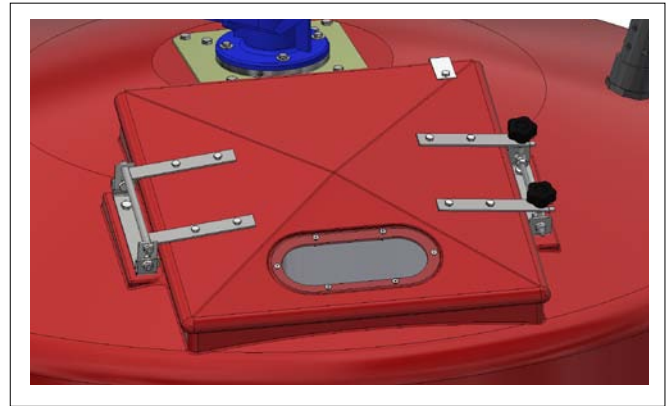

Hatch

MOUNTING INSTRUCTION - RESIDUAL TANK

PLACING THE WARNING SIGNS

A warning sign is applied to the tank in two places, as shown. Use the clear cover labels (45x45 mm) to cover the icons not relevant to the specific tank; e.g. *acid*, *UV light* and *moving parts*. For example: If a UV light cleaner is not installed in the tank, the icon for *UV light* is covered.

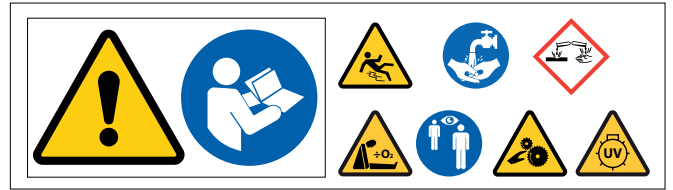

Warning sign

	READ THE MOUNTING INSTRUCTION! Read this manual thoroughly before mounting, use and service.
	CORROSIVE SUBSTANCES! The tank can contain acidic substances that can cause corrosive damage to skin and material.
	SLIPPERY! Risk of wet and slippery areas in and around the tank.
	MOVING PARTS! Risk of crushing due to moving machinery in the tank.
	LACK OF OXYGEN! There is no oxygen in the tank. Before entering the tank, be sure to vent the tank thoroughly.
	UV-LIGHT! The tank can contain UV light that can cause eye damage.
	SUPERVISION REQUIRED! A supervising person is required outside of the tank, when someone is working in the tank.
	WASH YOUR HANDS! Clean yourself and used tools thoroughly after working around the tank. Disposable tools (e.g. gloves) are discarded.



Where to place the warning signs

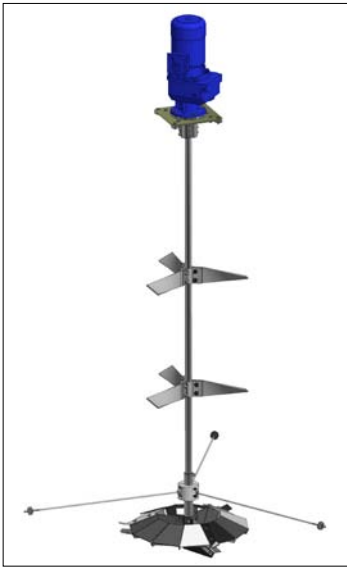

1. Gear motor
2. Tank flange
3. Coupling
4. Shaft
5. Middle agitator (number depends on the size of the tank)
6. Paddle for bottom agitator
7. Wing blade
8. Stay bolt for split bearing bush
9. Split bearing bush
10. Bottom agitator (3 parts)

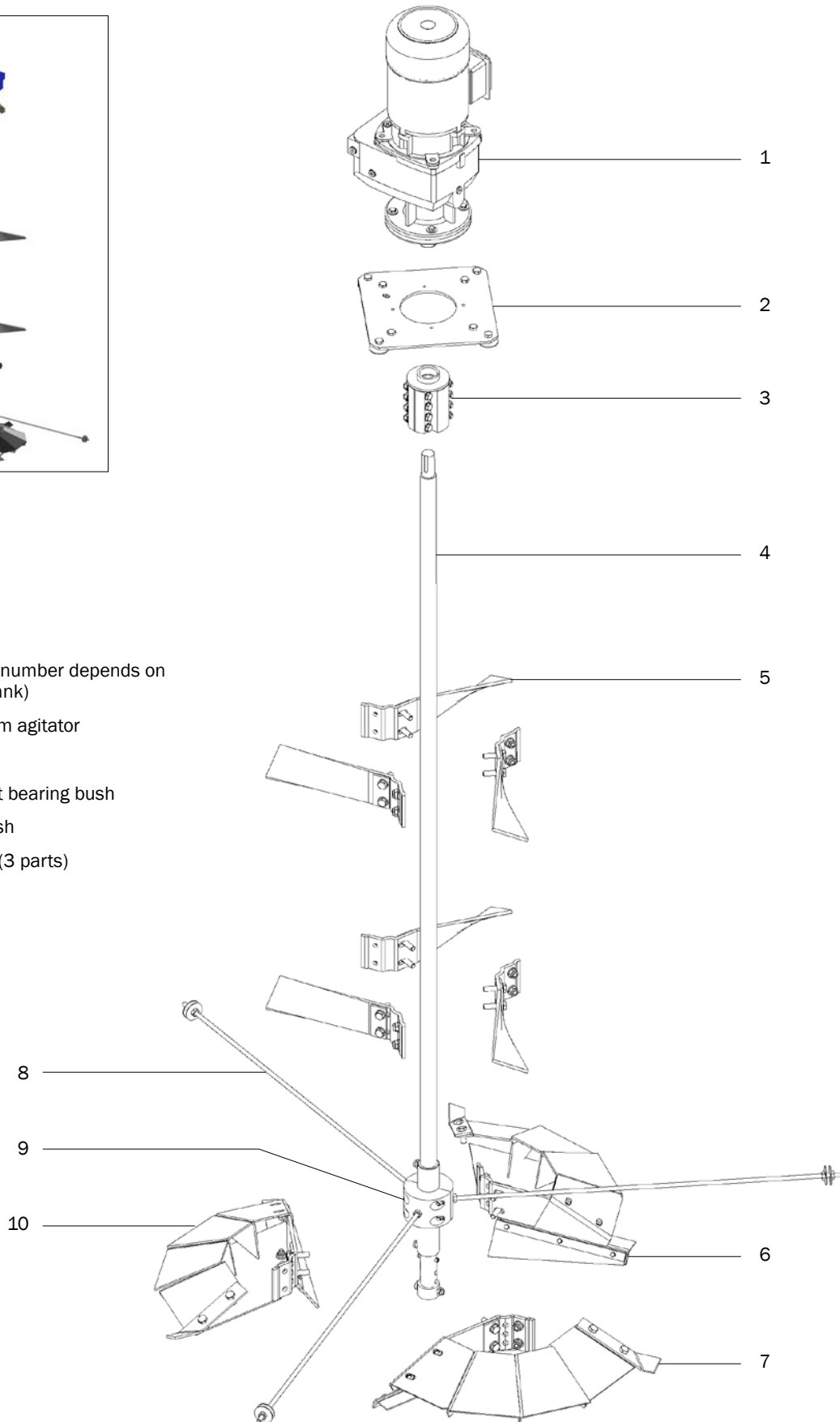

MOUNTING OF TOP FLANGE (FOR GEAR MOTOR)

The top flange is mounted centrally over the hole in the top of the tank. Use the flange as a template for drilling 8 holes. Use sealing tape on the inside around the screws, and fasten the flange using washers and nuts.

Seal the joint along the edges of the hole and the flange. (It is advised to apply the sealants last, due to the discomfort of the smell.)

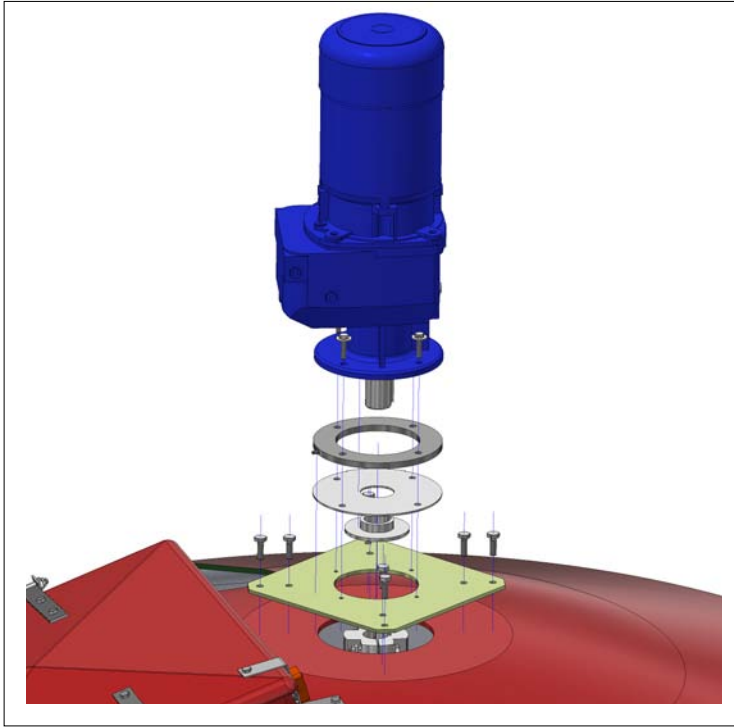

Mounting of gear motor and topflange

MOUNTING OF GEAR MOTOR

The gear motor is placed directly onto the top flange, and is fastened.

Insure proper ventilation for the gear motor.

Avoid impact on the shaft!

See appendix for service and maintenance of the gear motor.

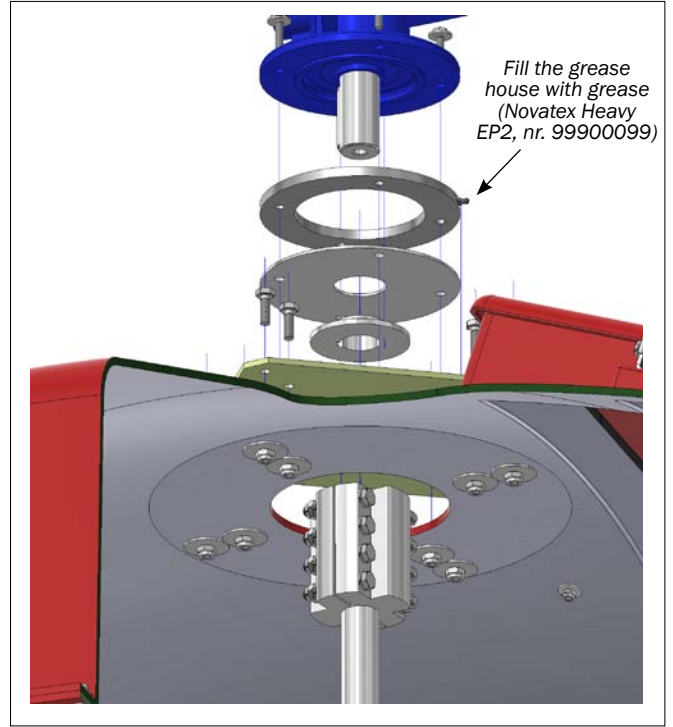

MOUNTING OF SHAFT FOR STIRRER

The shaft for the stirrer is mounted on the free end of the gear motor shaft using the clamp coupling. Make sure that the shaft ends of the gear motor and the stirrer are clean and free of tape etc. The steel bushing (with the split bearing bush) is mounted on the shaft before mounting the clamp coupling.

Next, the shaft for the stirrer (with the coupling) is pushed up to the free shaft end of the gear motor so that the two shafts meet. Maintain this position while the 4 bolts are carefully fastened.

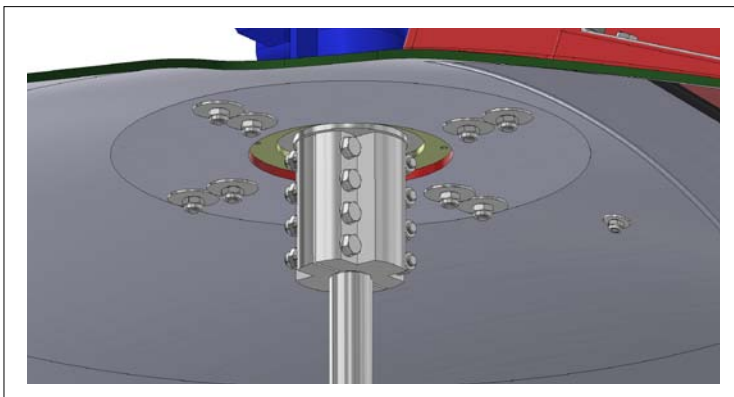

Clamp coupling

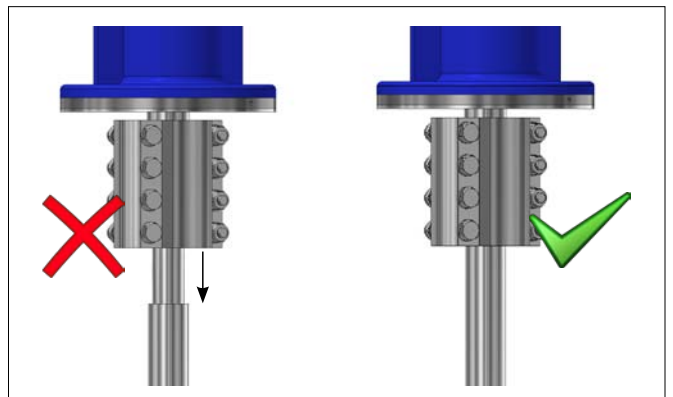

Push the clamp coupling all the way down to the neck of the shaft

MOUNTING OF BOTTOM AGITATOR

First, assemble two of the three parts of the bottom agitator loosely on the floor (see ill.). Mount one of the three wing blades at the joint of the two agitator parts.

One of the three paddles is mounted on the third part of the bottom agitator (see ill.). Place the fixing plate (with screws) on the paddle, and mount both parts on the bottom agitator from the bottom side.

Next, mount the three parts of the bottom agitator around the shaft just above the bearing bush (in the bottom end of the shaft).

Mount the remaining two wing blades.

Mount the remaining two paddles in the same way as the first.

Use a torque wrench (117 Nm) when tightening all screws and nuts - it is especially important to insure that the bottom agitator is soundly fixed to the shaft.

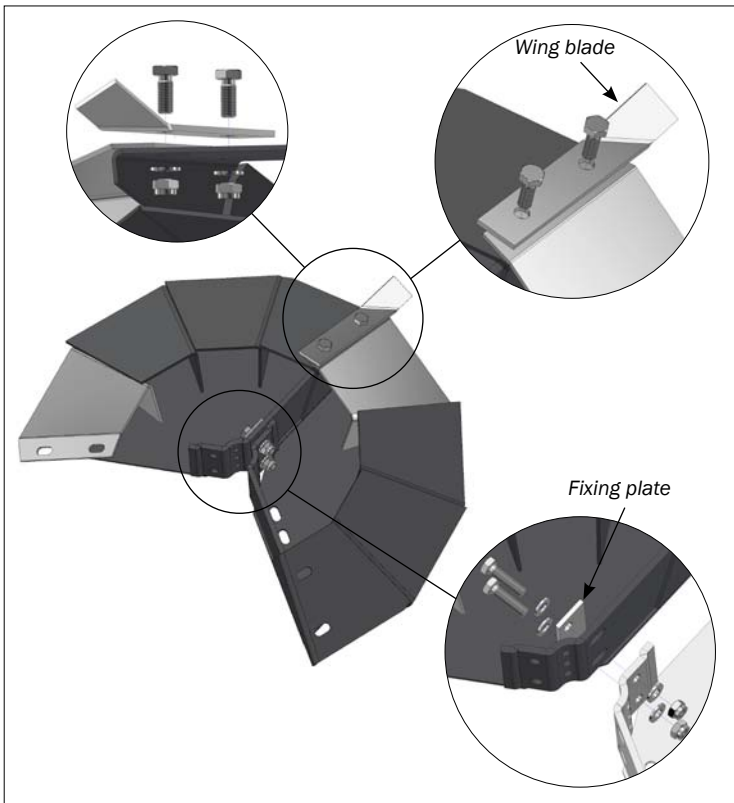

1. Two of the three parts of the bottom agitator are assembled, and a wingblade is mounted onto it

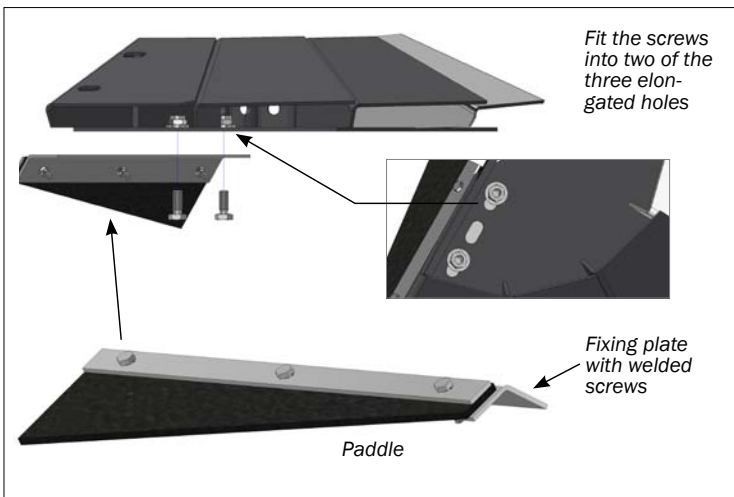

2. Mounting of paddle

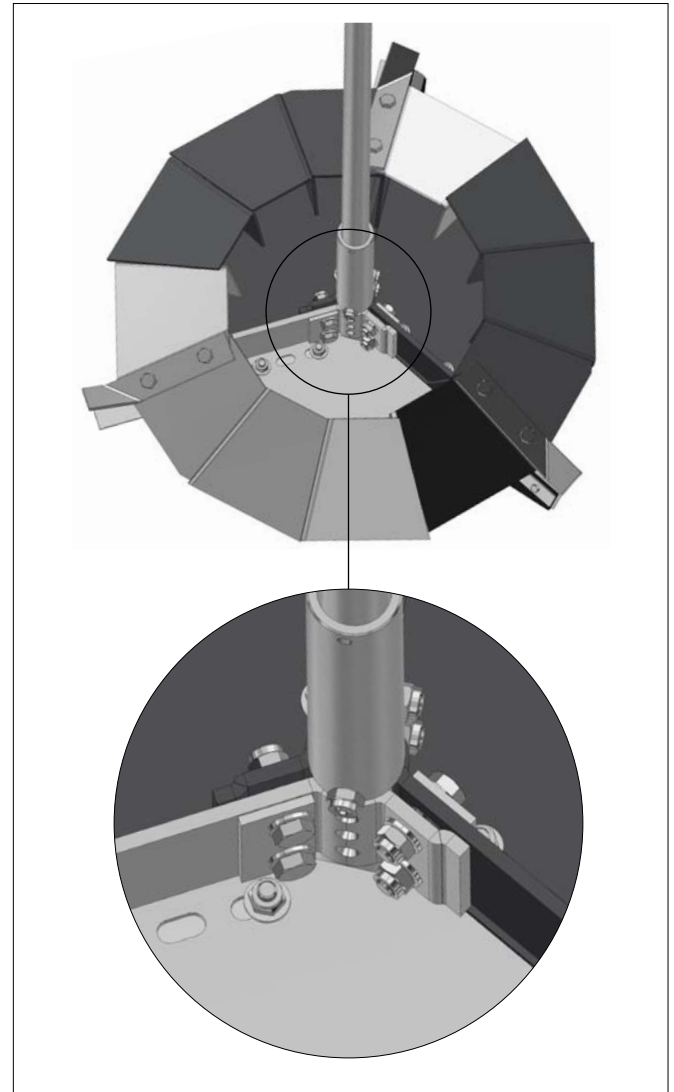

3. The three parts are fixed around the shaft

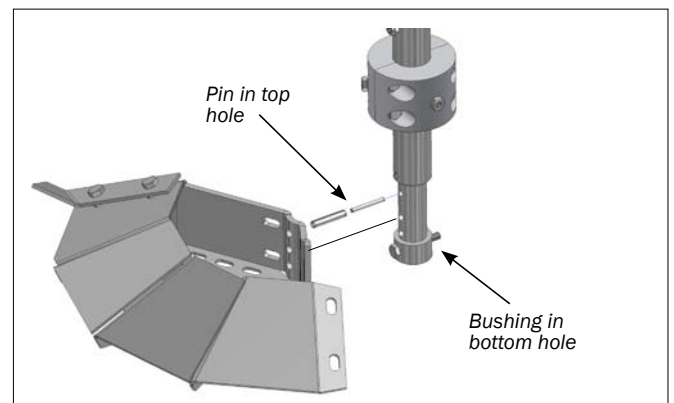

Placing of pin and bushing - for positioning the bottom agitator

MOUNTING OF SPLIT BEARING BUSH

The split bearing bush is mounted in the bottom end of the shaft to absorb radial forces on the stirrer.

The steel bushing (with split bearing bush) is mounted on the shaft before the shaft is mounted on the gear motor. The split bearing bush is carried by three stay bolts which are fixed through the sides of the tank (see ill.) The placement of the stay bolts is illustrated on the next page.

Place the stay bolt so that the end with the long thread is turned outward to the tank side. Screw the other end into the split bearing bush, **but not all the way to the steel bushing**, and fix it with a nut.

Make sure that the stay bolts do not deform the plastic bearing.

Adjust the bearing up/down to level the stay bolts, and fix the bushing to the shaft with the hexagon screws. Remember to seal with sealing tape (see ill.).

Check that the stay bolts and the split bearing bush are fixed tightly. Tighten them more if needed.

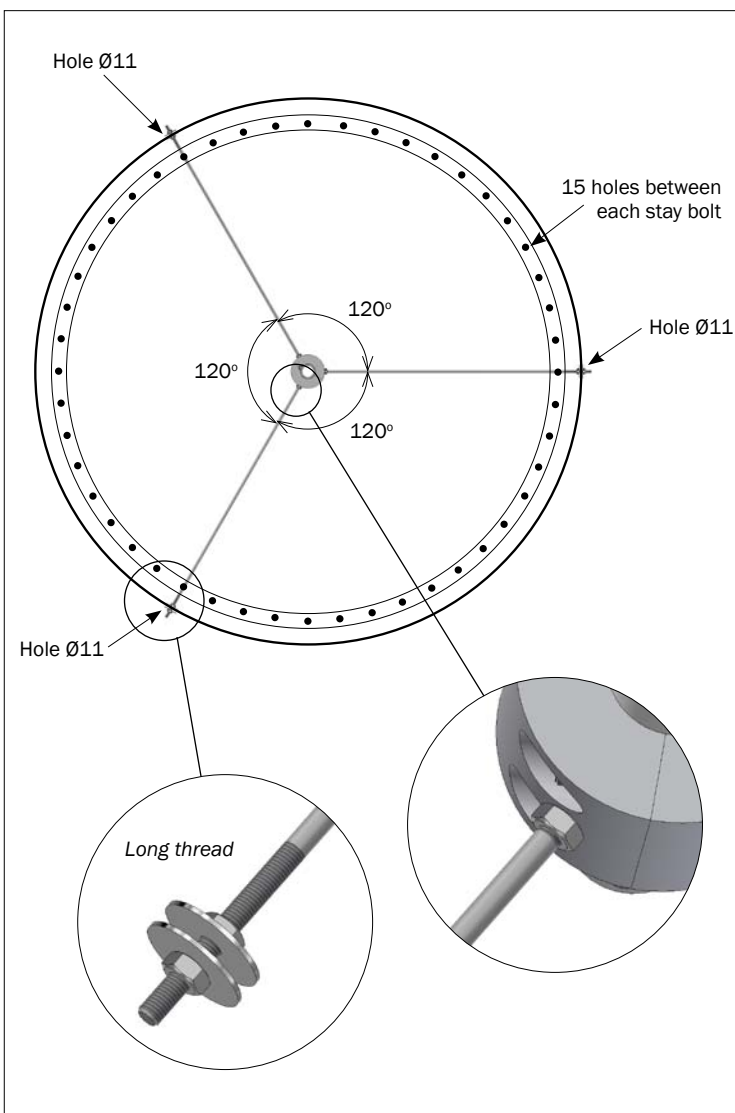

Split bearing bush, placement of stay bolts

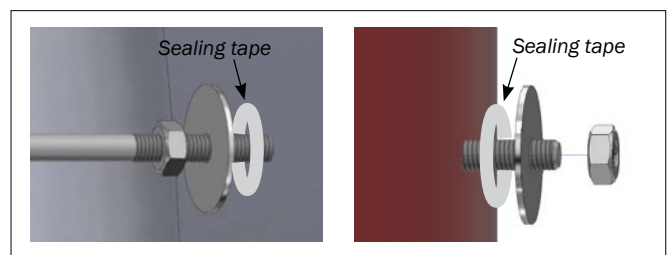

Stay bolt, inside

Stay bolt, outside

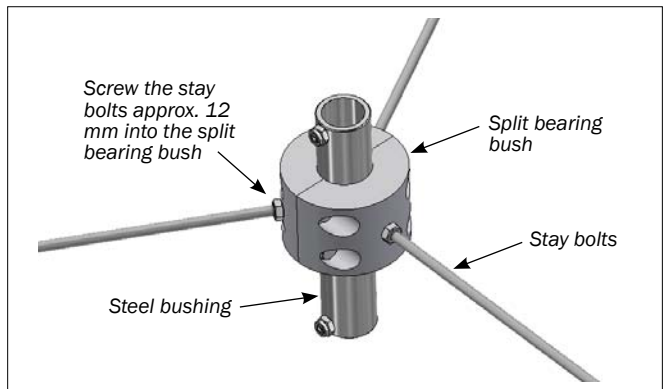

Split bearing bush, assembled

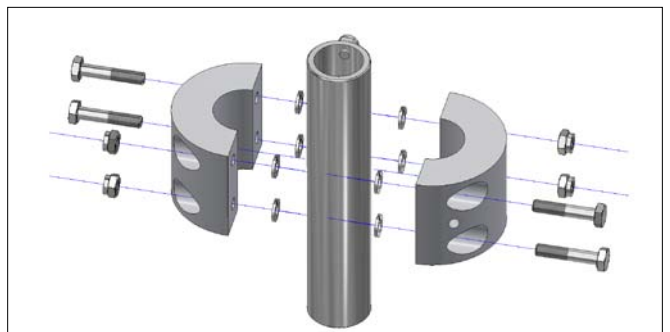

Split bearing bush, unassembled

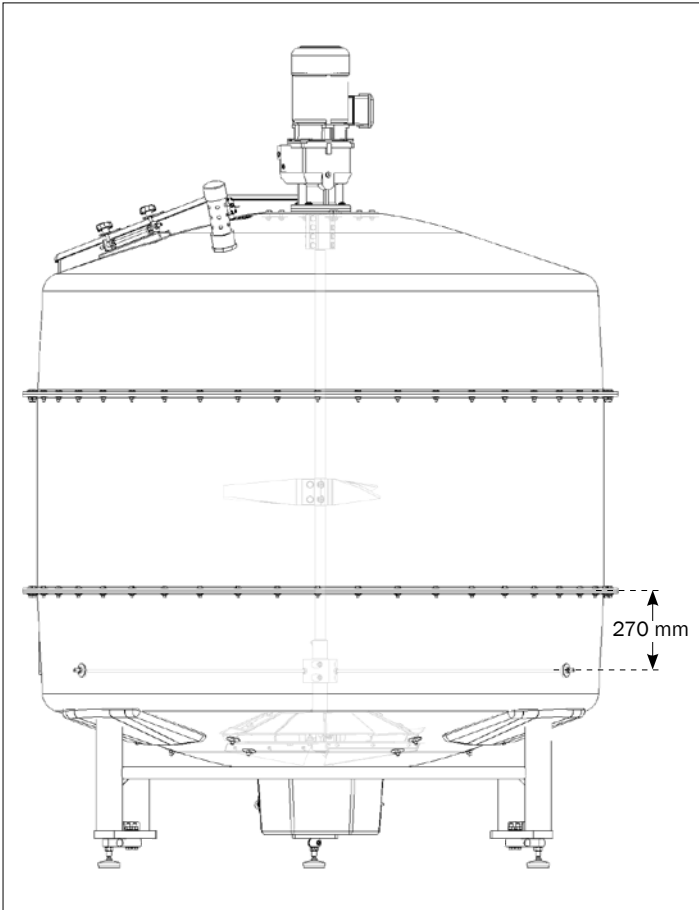

For the tanks of 2300, 4200 og 6000 L, one split bearing bush with stay bolts is mounted. Drill the holes as shown on the illustration - approx. 270 mm below the bottom fiberglass joint.

Placement of split bearing bush in the tanks of 2300, 4200 and 6000 L

MOUNTING OF MIDDLE AGITATOR

One middle agitator is mounted per fiberglass part of the tank:

- 2300 L - 0 middle agitators
- 4200 L - 1 middle agitator
- 6000 L - 2 middle agitators

For the tanks with more than one middle agitator, the agitators are distributed regularly through the tank (see ill. below).

First, assemble two of the three wings of the middle agitator loosely on the floor (see ill.).
Then, assemble the two parts with the third around the shaft of the stirrer in the tank.

Fix the middle agitator around the shaft in the correct position and tighten screws and nuts with a torque wrench (approx. 117 Nm).

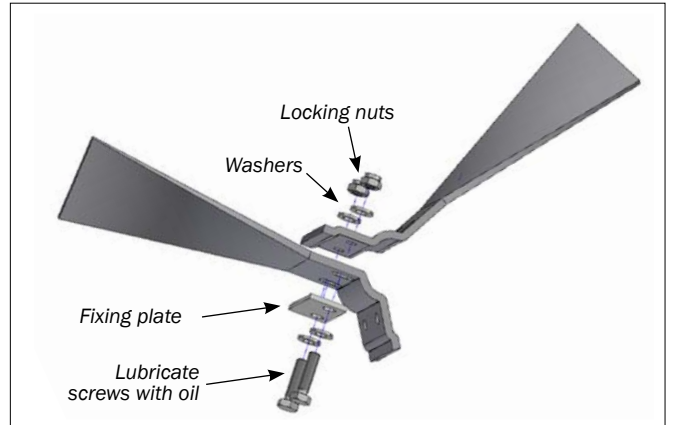

Two of the three parts of the middle agitator are assembled loosely on the floor

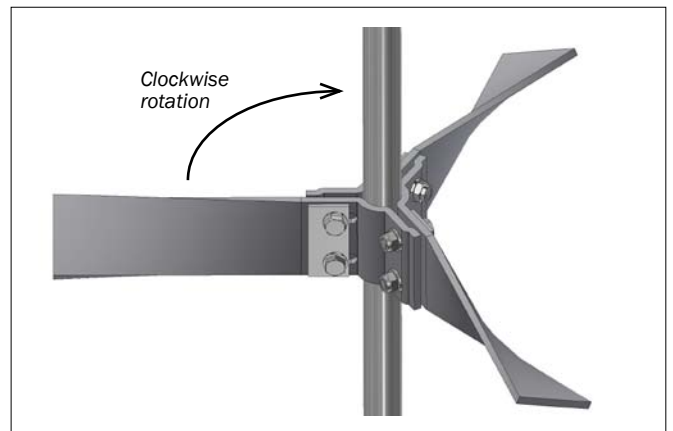

Middle agitator, assembled

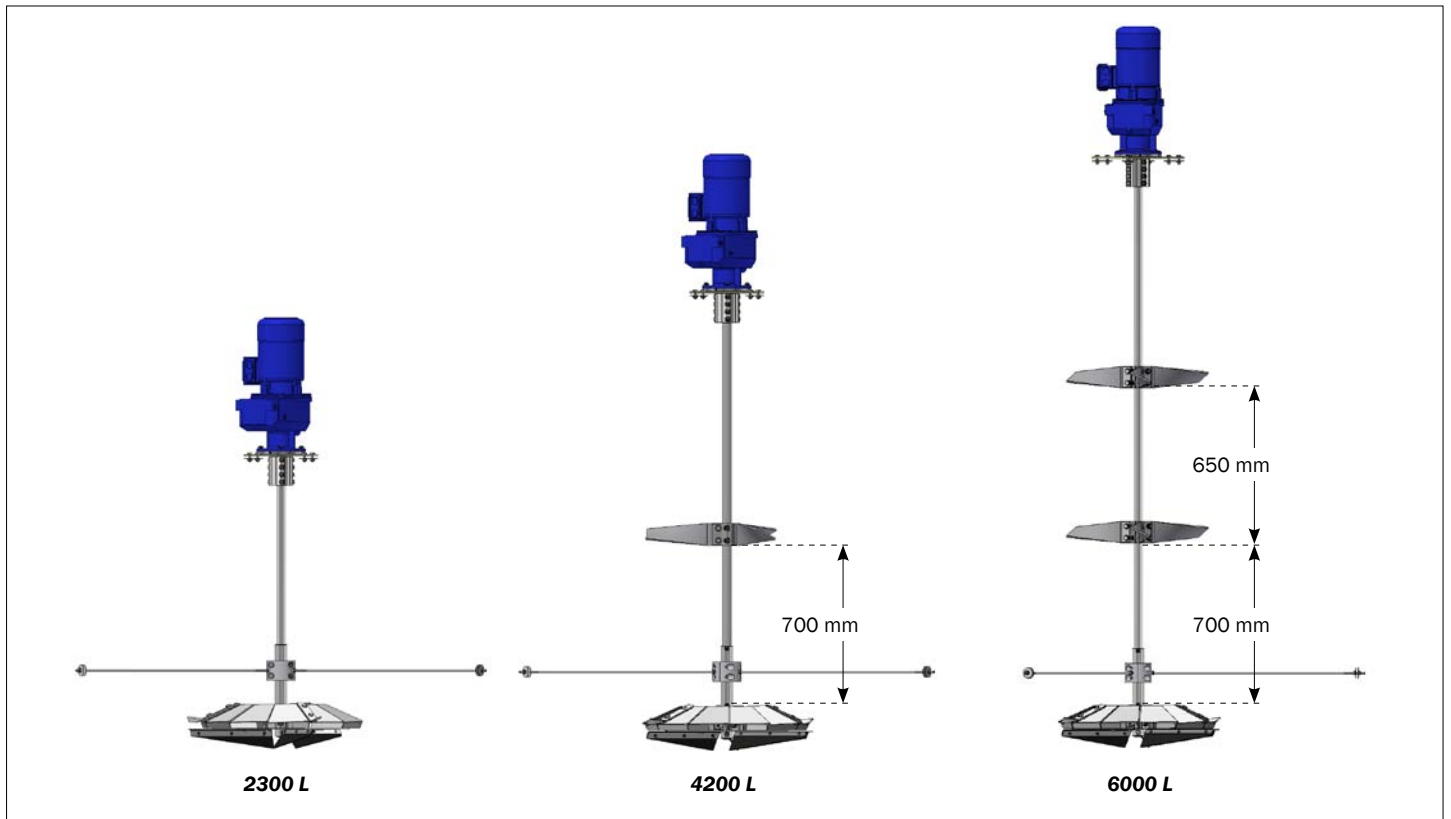

Placement of middle agitators

PIPE FOR CONNECTING THE PUMP

A ball valve, a PVC pipe and a piece of flexible hose are mounted on the outlet connection. The feed pump is then connected to the flexible hose. The piping from the outlet to the pump should be as short as possible.

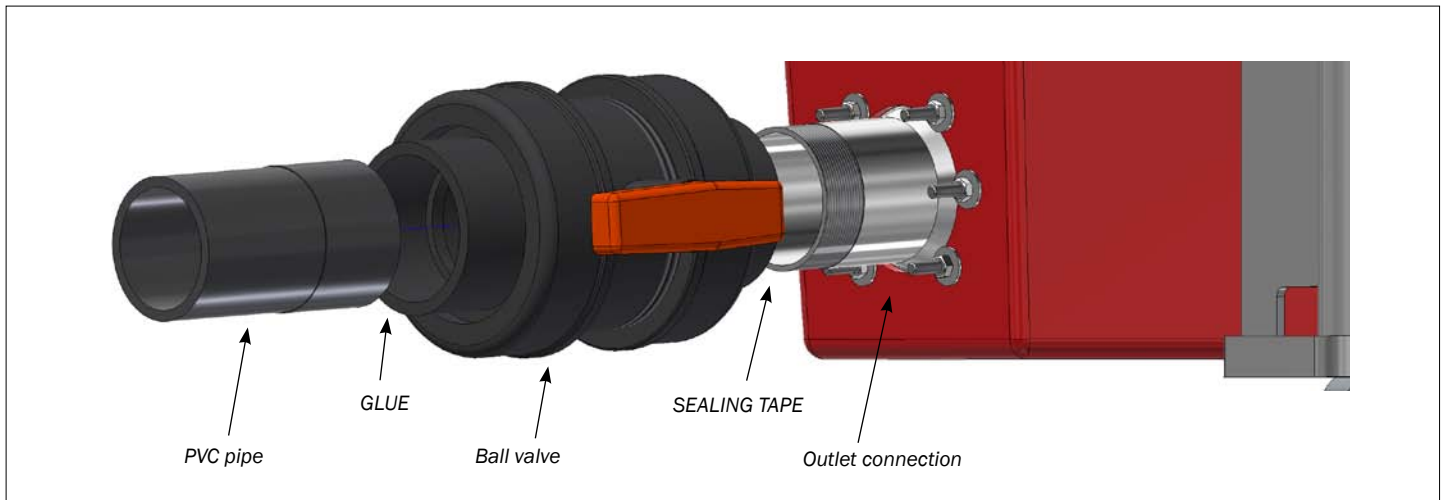

Pipe for connecting the pump

PIPE FOR INTAKE OF LIQUID COMPONENTS

The intake for liquid components (except water and acid) is placed in the top of the tank (see ill.). Remember to carefully seal the passage around the hole with sealing tape. The piping for liquid components should be joint into one pipe immediately before the tank.

Intake of water through the bottom of the tank:

Water can be let in via the pipe for the feed pump in the bottom of the tank (see ill.).

Intake of acid

Inlet of acid is to be placed separately in the top, opposite the hatch, and as near the wall of the tank as possible (see ill.).

PIPE FOR INTAKE OF DRY COMPONENTS

The intake for dry components is placed in the top of the tank (see ill.). Use the intake pipe as a drill template.

Carefully seal the contact face with sealing tape. Place the pipe in the hole and mount it with screws (from the outside) and washers and nuts (on the inside).

Mount a rubber sleeve on the upper part of the intake pipe using a clamp ring.

All pipes for intake are ordered separately.

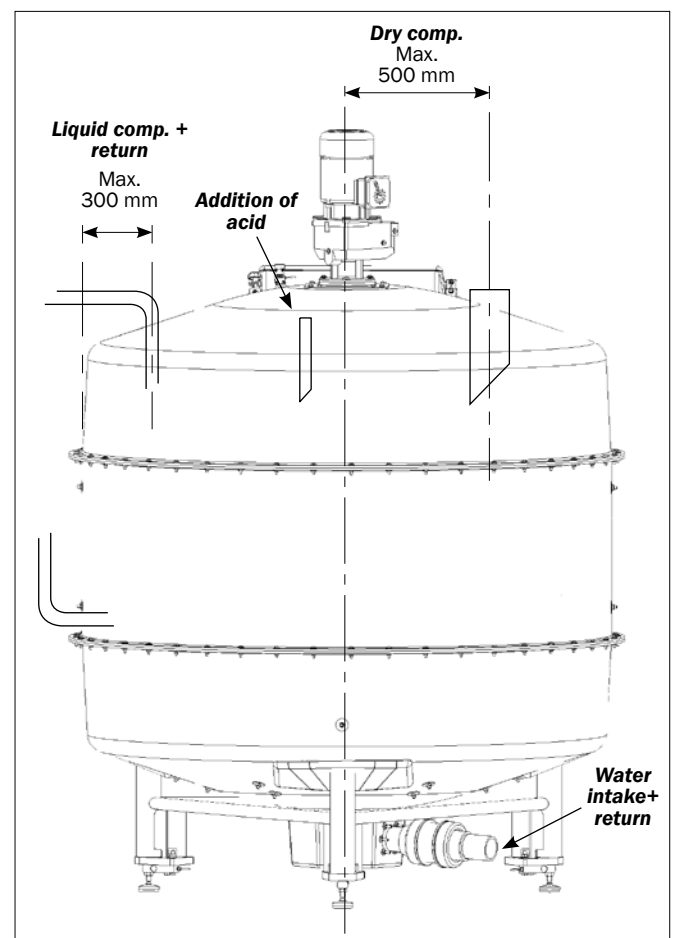

Intake of liquid and dry components

RETURN PIPES

The return pipes should be brought together into one pipe, immediately before the tank. There are several options for placing return inlets:

- At the top of the tank, approx. 300 mm from the side of the tank (in the same way as the inlet pipe for liquid components).
- In the side of the tank (be aware of steps, counter agitators and other elements mounted in the tank).
- At the bottom of the tank (through the pipe for the feed pump)

Be aware that the feed jet from the return pipe must not be directed directly into the bottom of the tank, as this allows air to be drawn out into the feed pipe.

PIPE FOR VENTILATION OF THE TANK

The ventilation pipe is placed in the top of the tank. Remember to seal the passage with a flexible sealant around the hole.

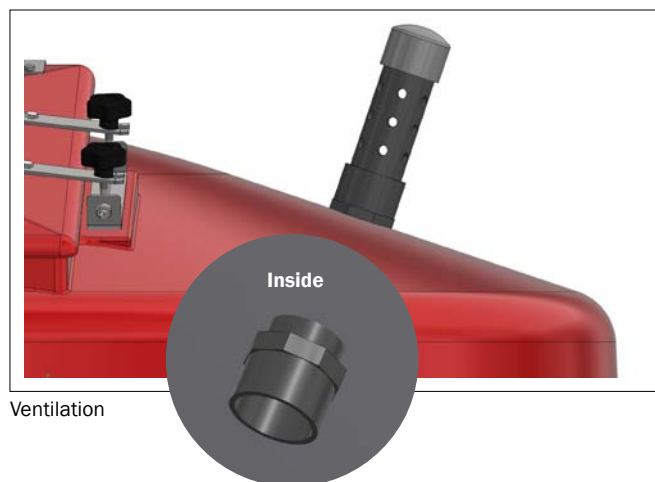

MOUNTING OF LEVEL TILTING DEVICE

The level tilting device is mounted in the ventilation pipe. Fixate the device with cable ties (as shown) to keep it away from the stirrer.

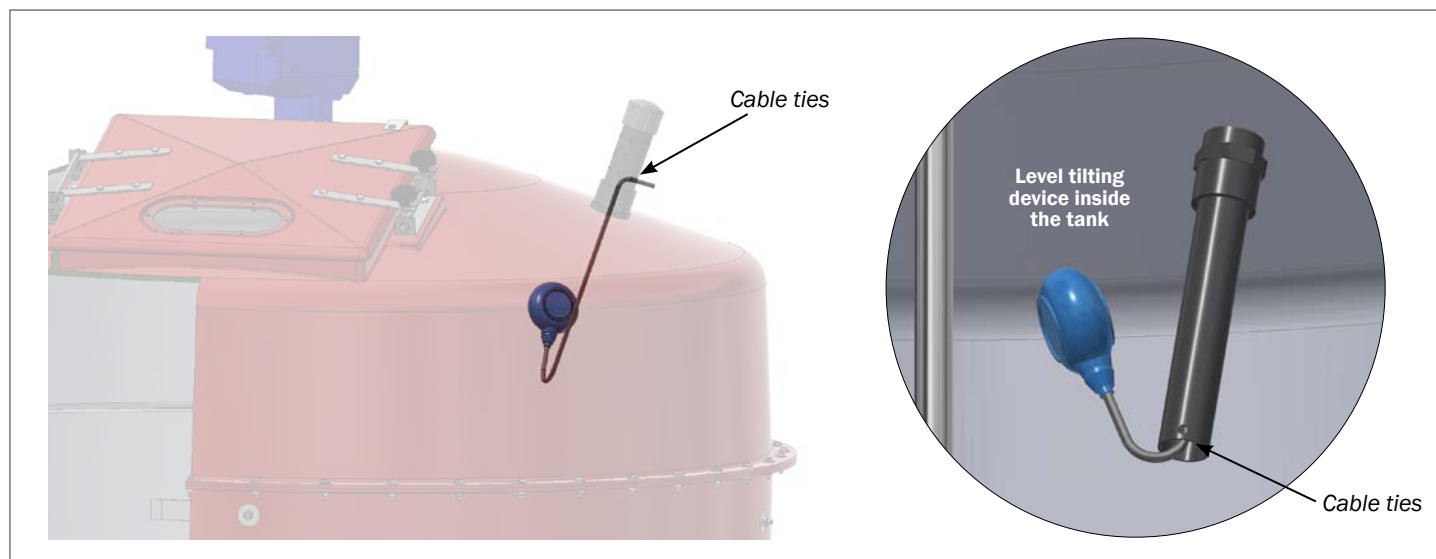

SAFETY SWITCH

A sensor (safety switch) is mounted onto the hatch, securing that the motor disconnects when the hatch is opened.

The brackets for the switch are mounted on the hatch and tank with the supplied set screws and locking nuts. Seal around the screws with sealing tape.

Mount the sensor on the brackets using hexagon socket screws. The part of the sensor with the cable is mounted on the bracket on the tank.

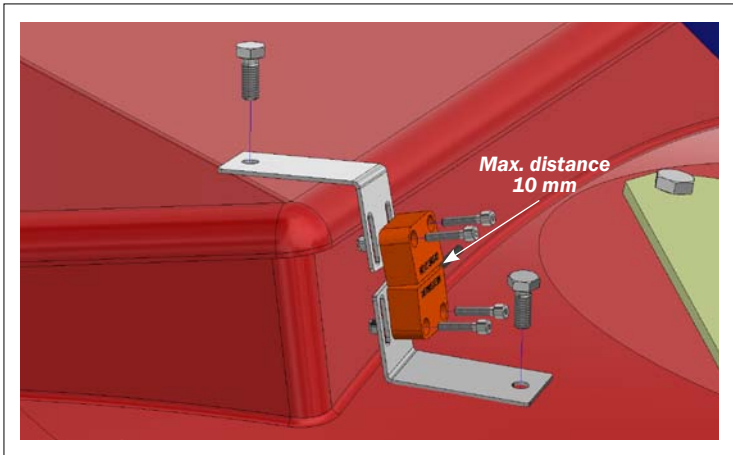

Safety switch on hatch

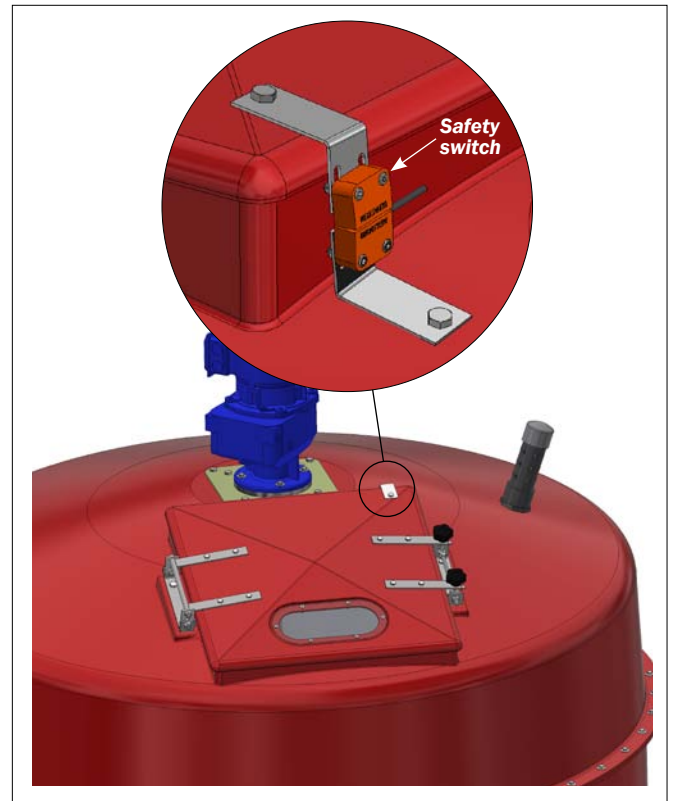

INTERNAL WASHING OF THE TANK, MANUALLY

If you wish to wash the tank thoroughly on the inside, you can use a high pressure cleaner. Please note the following safety precautions:

- Before opening the tank, the tank must be ventilated thoroughly. This is best done by removing the inspection cap in the bottom of the tank and rinse the tank thoroughly with water
- All work in the tank must always be supervised by a person outside of the tank

DISASSEMBLY - SAFETY PRECAUTIONS

When disassembling parts of the tank, please note the following safety precautions:

- Disconnect the power for the gear motor when dismantling parts and when working in the tank. All work in the tank must always be supervised by a person outside of the tank
- Before opening the tank, the tank must be ventilated thoroughly. This is best done by removing the inspection cap in the bottom of the tank and rinse the tank thoroughly with water
- When the safety precautions have been followed, one or more parts can be demounted. See this instruction for information on how the tank parts have been assembled

SERVICE AND MAINTENANCE OF THE GEAR MOTOR

IMPORTANT SAFETY PRECAUTIONS:

- All work on the gear motor regarding transportation, installation, service and maintenance must be carried out by trained personnel
- There is a risk of injuries due to fast rotating and possibly hot machine parts. Installation and maintenance must only be carried out on stationary and cooled gear. The drive must not be energized and must be secured against accidental connection
- Wear protective gloves - there is a risk of burns due to hot oil
- After disconnection from supply voltage, live parts of the appliance and power connections must not be touched immediately as the capacitors may be charged

SERVICE- AND MAINTENANCE INTERVALS	
Interval	Task
Min. every 6 months	<ul style="list-style-type: none"> • Visual control • Control of noise • Oil level control • Visual control of tube • Lubrication with grease (grease house between gear and tank) • Replacement of the automatic lubrication system / excess grease is removed (At operational times < 8 hrs. / day: the interval for changing the lubrication system is up to 1 year. Every second time the lubrication system is changed, the lubrication collecting container is emptied or changed)
At operating temperatures of up to 80°C: After every 10,000 operating hours, at least every 6 months	<ul style="list-style-type: none"> • Change the oil (When using synthetic products, the interval doubles) • Clean the ventilation valve. Replace, if needed • Replace the sealing rings for the shaft, if they are worn

Visual control:

- Check the gear unit for leaks, external damage and cracks in hose lines, hose connections and rubber buffers
- For leaks, such as dripping gear oil or e.g. refrigerant, damage or cracks, the gear must be repaired

Control of noise:

- Noise or vibrations in the gear are signs of damage to the gear unit. Disengage the gear unit and carry out a general inspection

Oil level control:

- Only check the oil level when the gear is disengaged, stationary and cooled off. The drive must not be energized and must be secured against accidental connection

Lubrication with grease:

- The grease house is replenished with grease (see illustration in this mounting instruction under "Mounting of the gear motor"). When using acid vapor cleaners in the tank, the grease house is replenished every 3 months.

Replacing the automatic lubrication system:

- Unscrew the protection cap
- Unscrew the lubrication system, and replace it with a new system
- Remove excess grease from the adaptor
- Activate the automatic lubrication system

Every second time the lubrication system is changed, the lubrication collecting container is emptied or changed. Empty the container by unscrewing it. The plunger in the container is pushed in and the pressed out grease is removed. The container is cleaned and screwed in again. If the container is damaged, replace it with a new one.

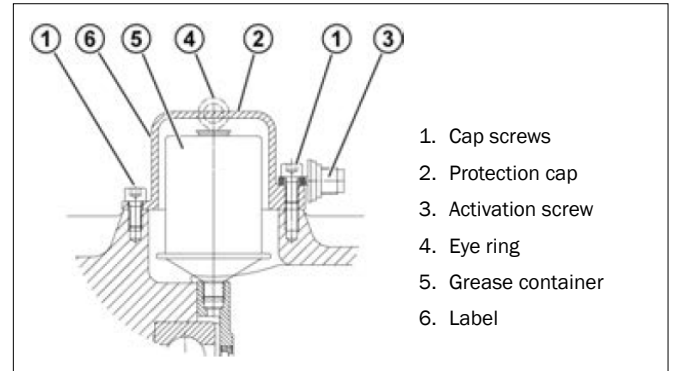

Changing the oil:

- Cool the gear. Wear protective gloves due to possibly hot oil
- Place a drip tray under the outlet
- Unscrew the oil level plug completely
- Let all the oil run out of the gear
- Screw the oil drain plug in, and tighten it
- Fill with new oil until the oil starts to run out of the oil level hole. If using an oil level container, the oil is filled via the containers top opening.

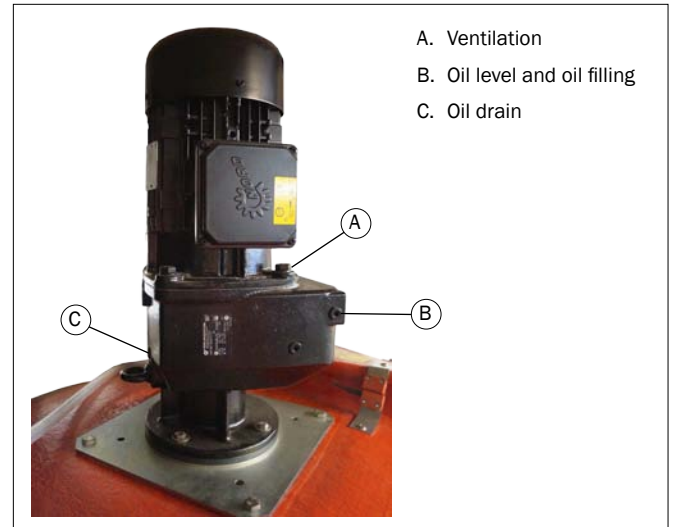

Cleaning (or replacing) the ventilation valve:

- Unscrew the ventilation valve and clean it (e.g. using an air compressor). Screw it back in.
- Replace the valve (incl. sealing ring), if needed

Replacing the sealing ring for the shaft:

- When a distinct leakage of dripping oil is formed around the sealing lips, the shaft seal ring must be replaced
- During assembly, the space between the sealing- and the protective lip is filled approx. 50% with grease
- Note: the new sealing ring must not continue in the track of the old ring

Lubrication types

BEARING GREASE: Novatex Heavy EP 2, item no.. 99900099

OIL: Mineral oil ISO VG 220

BILL OF MATERIALS - RESIDUAL TANK 2300 L

BILL OF MATERIALS - RESIDUAL TANK 2300 L, WITHOUT STIRRER			
	Item no.	Description	Pcs.
	0340-234	RESIDUAL TANK 2300 L	
1	0140-110	Bottom part for tank VF	1
2	0140-120	Top part for tank VF	1
3	30308035	Set screw A2 M8 X 35 DIN 933	45
4	33508013	Nut M8 A2 DIN 934	63
5	35600058	Nut washer Ø8x8,4/24/2 A2 DIN 9021	104
6	0139-710	Bottom agitator VF4-B SS	6
7	0139-547	Disc Ø45/10,5X2 stainless	12
8	30310030	Set screw A2 M10 X 30 DIN 933	12
9	33510017	Nut M10 A2 DIN934	12
10	0300-216	Ventilation for Liquid feeding tank	1
11	0139-506	Load cell manikin kit VF4	3
12	71200012	Level Tilting Device/Filling	1
13	0140-040	ACO Funki logo label 30x30cm for LF tank	1
14	29100001	Thread tape 1 roll= 10M	1
15	99900099	Grease, acid protection house to gear, LF-tank	1
16	74520	Flexible water sealer 300ML	1
17	29900003	Joint band 6m, sold in rolls of 8m	16

	Item no.	Description	Pcs.
18	0139-495	Inspection Flange VF4	1
19	0138-451	Membrane DN40	1
20	0139-496	Inspection cover VF4	1
21	0140-140	Outlet pipe for liquid feeding tank VF7	1
22	0140-028	Bracket for sensor	2
23	0140-026	Safety RFID Sensor IP69, 5m cable	1
24	0140-027	Safety RFID Sensor IP69 Key	1
25	0140-064	PVC BallValve 3"/ Ø90	1
26	0140-063	PVC pipe Ø90 for 3" valve	1
27	30308020	Set screw A2 M8 X 20 DIN 933	2
28	33908001	Lock nut A2 M8 DIN 985	2
29	38504020	Hexagon socket screw M4x20 CH A2 DIN 912	4
30	33904000	Lock nut M4 A2	4
31	0140-036	Cover label 45x45 mm for 0140-035, white	6
32	0140-035	Safety label 35x10 cm for liquid feeding tank	2
33	0300-262	Tube for level tilting device/filling	1
34	76200023	Cable tie 290x4,5 mm	2

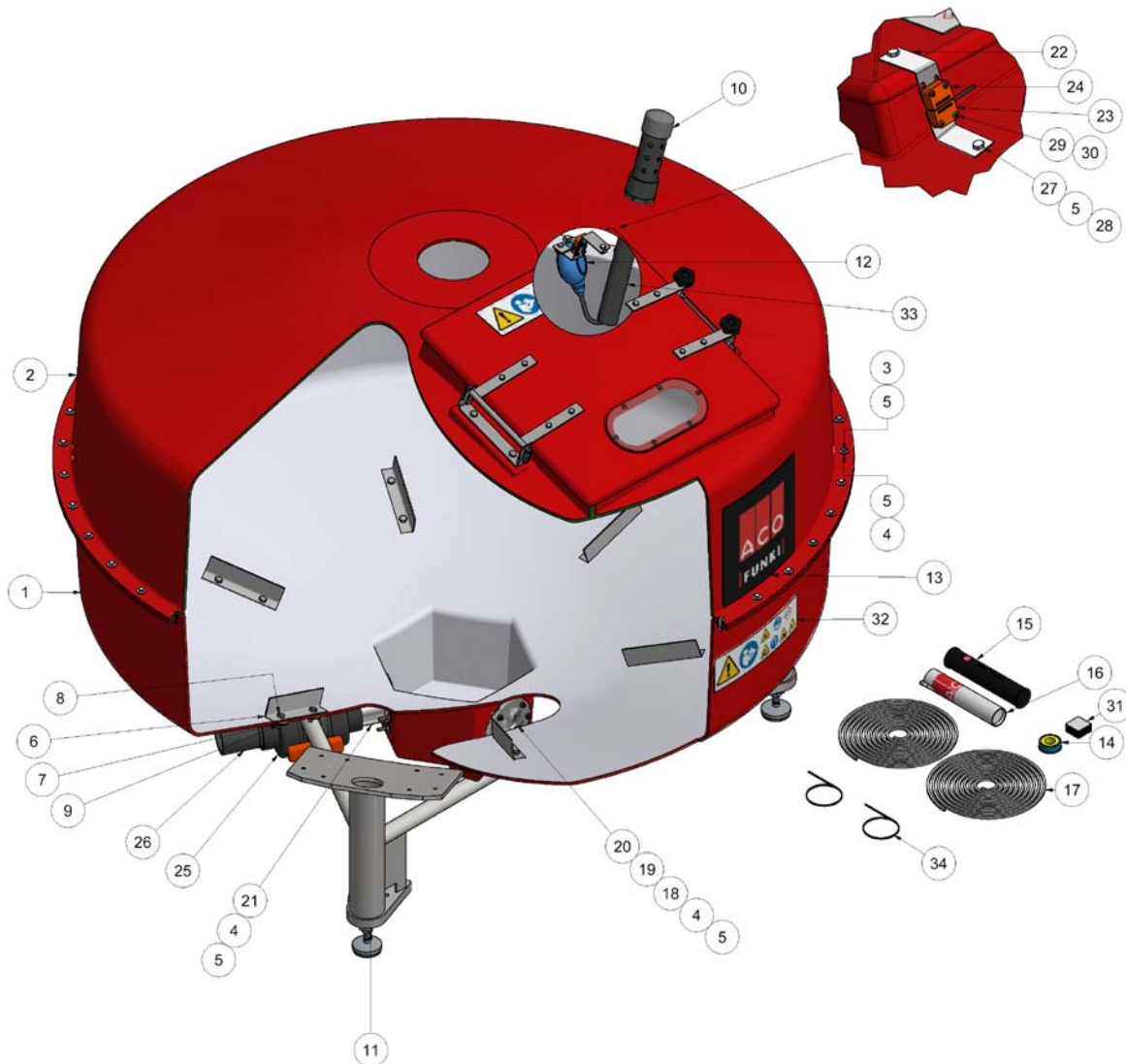

BILL OF MATERIALS - RESIDUAL TANK 2300 L, ONLY STIRRER			
	Item no.	Description	Pcs.
	0340-234	RESIDUAL TANK 2300 L	
1	0139-697	Shaft 2300 VF4-B Comp. Stainless	1
2	0139-651	Tension pl. for bottom agitator. Stainl.	3
3	0330-015	Slidbøsning lang	1
4	0330-020	Split bearing bush	1
5	0139-716	Bottom agitator 1/3 part VF4-B	3
6	0139-869	Paddle for bottom agitator	3
7	0139-717	Wing blade VF4-B	3
8	0139-547	Disc Ø45/10,5X2 stainless	14
9	30312045	Set screw M12X45 A2 DIN933	6
10	35600080	Flat washer Ø12x13/24/2,5 A2 DIN125	24
11	33912000	Lock nut A2 M12 DIN 985	18
12	33510017	Nut M10 A2 DIN934	9
13	30312030	Set screw M12X30 A2 DIN933	6

	Item no.	Description	Pcs.
14	0139-511	Stay bolt for bottom bearing VF4	3
15	0140-200	Coupling Ø30/Ø40X118 Stainless Steel	1
16	0139-999	Tank flange Ø200	1
17	35600058	Nut washer Ø8x8,4/24/2 DIN9021	4
18	30310030	Set scew A2 M10 X 30 DIN 933	8
19	33900029	Lock nut A2 M10 DIN 985	8
20	74038093	Gear motor SK32F 100LP/4 230/400	1
21	30308035	Set screw A2 M8 X 35 DIN 933	4
22	35600044	Star washer Ø8/8,4 A2 DIN 6798 A	4
23	0140-169	Lid for grease protection of large gear	1
24	0140-168	Bushing for protection of large gear	1
25	0140-167	House for grease for protection of large gear	1
26	9900001	Lubricating Nipple, M5 coned Type A DIN 71412	1

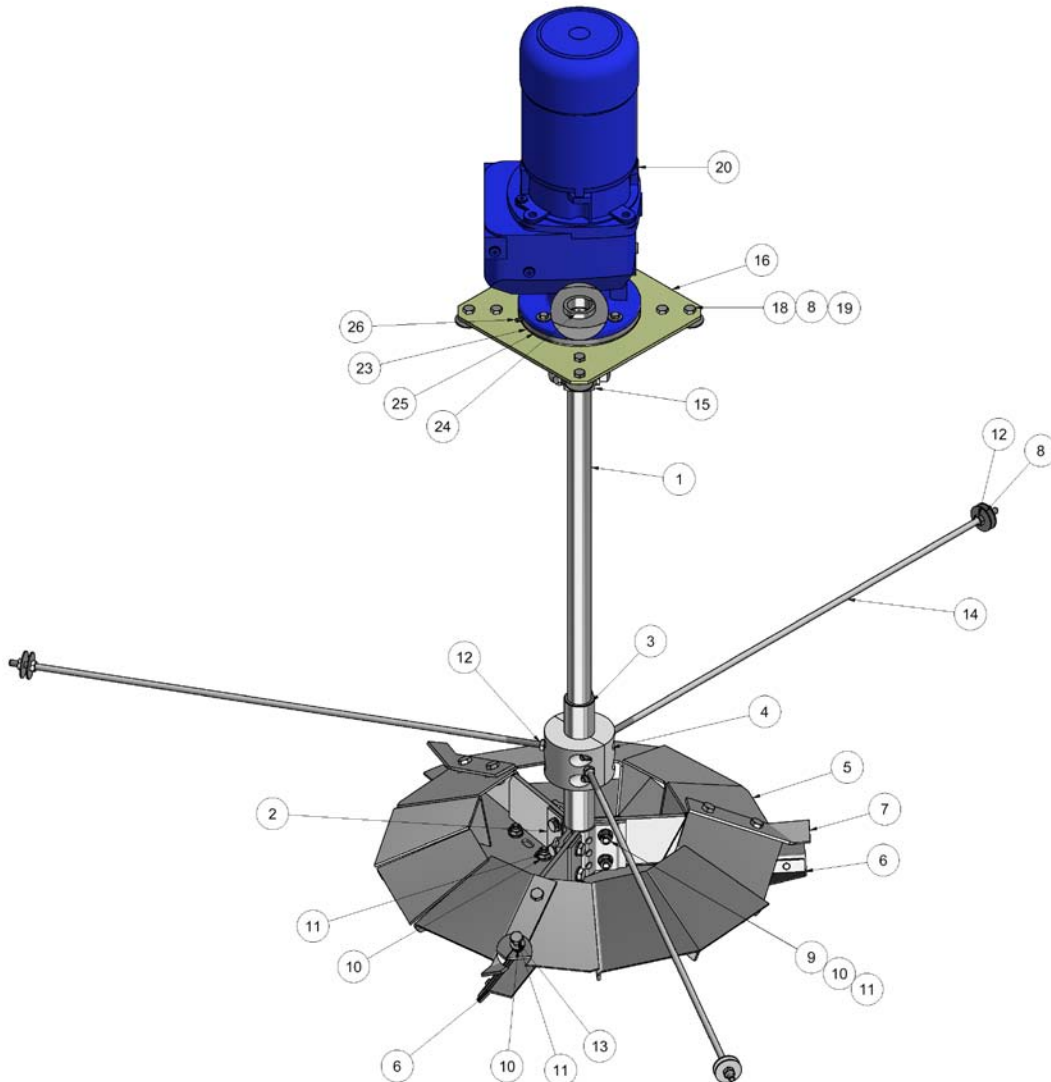

BILL OF MATERIALS - RESIDUAL TANK 4200 L

BILL OF MATERIALS - RESIDUAL TANK 4200 L, WITHOUT STIRRER			
	Item no.	Description	Pcs.
	0340-235	RESIDUAL TANK 4200 L	
1	0140-110	Bottom part for tank VF	1
2	0140-120	Top part for tank VF	1
3	0140-115	Middle part for tank VF7	1
4	30308035	Set screw A2 M8 X 35 DIN 933	90
5	33508013	Nut M8 A2 DIN 934	108
6	35600058	Nut washer Ø8x8,4/24/2 A2 DIN 9021	194
7	0139-710	Bottom agitator VF4-B SS	6
8	0139-547	Disc Ø45/10,5X2 stainless	20
9	30310030	Set screw A2 M10 X 30 DIN 933	20
10	33510017	Nut M10 A2 DIN934	20
11	0139-576	Step for mix tank	2
12	0300-216	Ventilation for Liquid feeding tank	1
13	0139-506	Load cell manikin kit VF4	3
14	71200012	Level Tilting Device/Filling	1
15	0139-534	Counter agitator VF4-A	2
16	0140-040	ACO Funki logo label 30x30cm for LF tank	1
17	29100001	Thread tape 1 roll= 10M	1
18	99900099	Grease, acid protection house, gear LF-tank	1

	Item no.	Description	Pcs.
19	74520	Flexible water sealer 300ML	1
20	29900003	Joint band 6m, sold in rolls of 8m	32
21	0139-495	Inspection Flange VF4	1
22	0138-451	Membrane DN40	1
23	0139-496	Inspection cover VF4	1
24	0140-140	Outlet pipe for liquid feeding tank VF7	1
25	0140-064	PVC BallValve 3"/ Ø90	1
26	0140-063	PVC pipe Ø90 for 3" valve	1
27	0140-028	Bracket for sensor	2
28	0140-026	Safety RFID Sensor IP69, 5m cable	1
29	0140-027	Safety RFID Sensor IP69 Key	1
30	30308020	Set screw A2 M8 X 20 DIN 933	2
31	33908001	Lock nut A2 M8 DIN 985	2
32	38504020	Hexagon socket screw M4x20 CH A2 DIN 912	4
33	33904000	Lock nut M4 A2	4
34	0140-035	Safety label 35x10 cm for liquid feeding tank	2
35	0140-036	Cover label 45x45 mm for 0140-035, white	6
36	0300-262	Tube for level tilting device/filling	1
37	76200023	Cable tie 290x4,5 mm	2

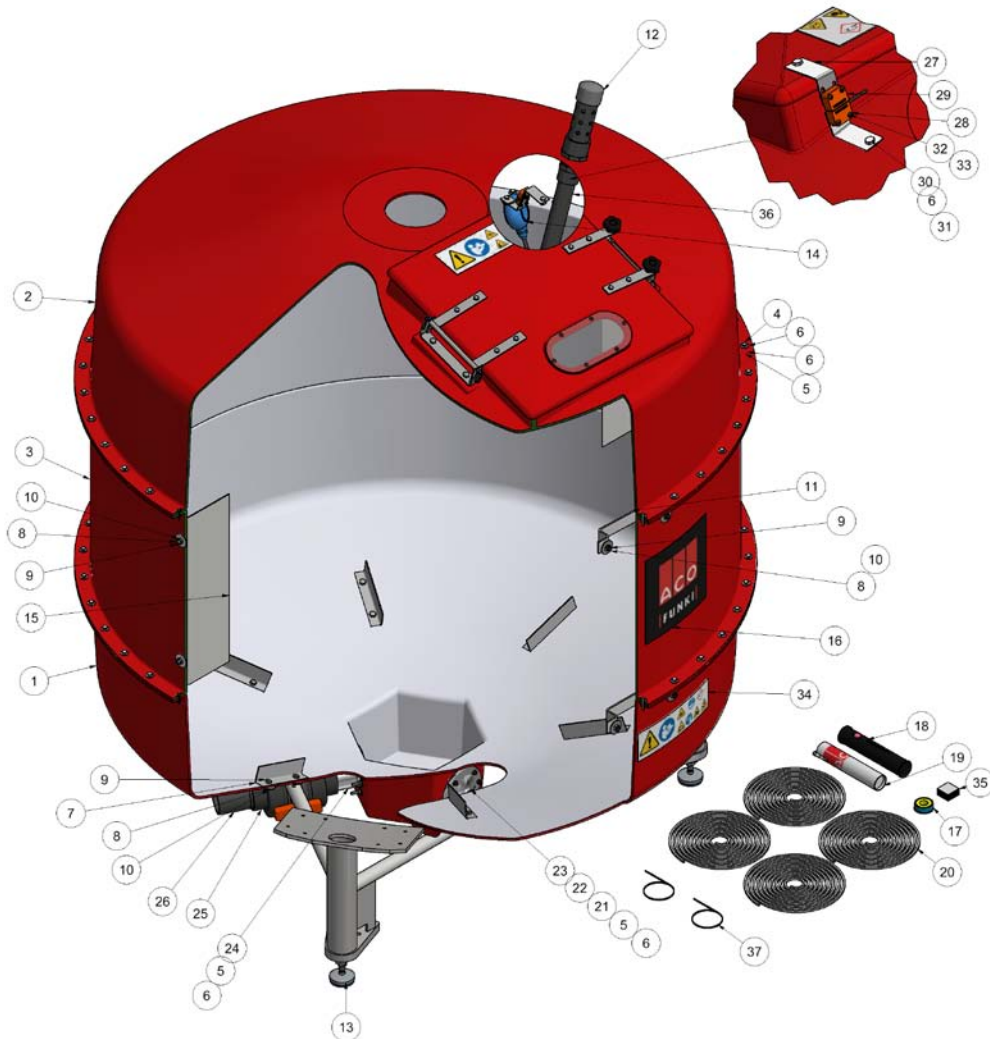

BILL OF MATERIALS - RESIDUAL TANK 4200 L, ONLY STIRRER			
	Item no.	Description	Pcs.
	0340-235	RESIDUAL TANK 4200 L	
1	0139-701	Shaft 4100 VF4-B Comp. Stainless	1
2	0139-714	Wing for middle tube	3
3	0139-651	Tension pl. for bottom agitator. Stainl.	6
4	0330-015	Wearing bushing, long	1
5	0330-020	Split bearing bush	1
6	0139-511	Stay bolt for bottom bearing VF4	3
7	0139-716	Bottom agitator 1/3 part VF4-B	3
8	0139-869	Paddle for bottom agitator	3
9	0139-717	Wing blade VF4-B	3
10	0139-547	Disc Ø45/10,5X2 stainless	14
11	30312045	Set screw M12X45 A2 DIN933	12
12	35600080	Flat washer Ø12x13/24/2,5 A2 DIN125	36
13	33912000	Lock nut A2 M12 DIN 985	24

	Item no.	Description	Pcs.
14	33510017	Nut M10 A2 DIN934	9
15	30312030	Set screw M12X30 A2 DIN933	6
16	0140-200	Coupling Ø30/Ø40X118 Stainlees Steel	1
17	0139-999	Tank flange Ø200	1
18	35600058	Nut washer Ø8x8,4/24/2 DIN9021	4
19	30310030	Set scew A2 M10 X 30 DIN 933	8
20	33900029	Lock nut A2 M10 DIN 985	8
21	74038093	Gear motor SK32F 100LP/4 230/400	1
22	0140-169	Lid for grease protection of large gear	1
23	0140-168	Bushing for protection of large gear	1
24	0140-167	House for grease for protection of large gear	1
25	9900001	Lubricating Nipple, M5 coned Type A DIN 71412	1
26	30308035	Set screw A2 M8 X 35 DIN 933	4
27	35600044	Star washer Ø8/8,4 A2 DIN 6798A	4

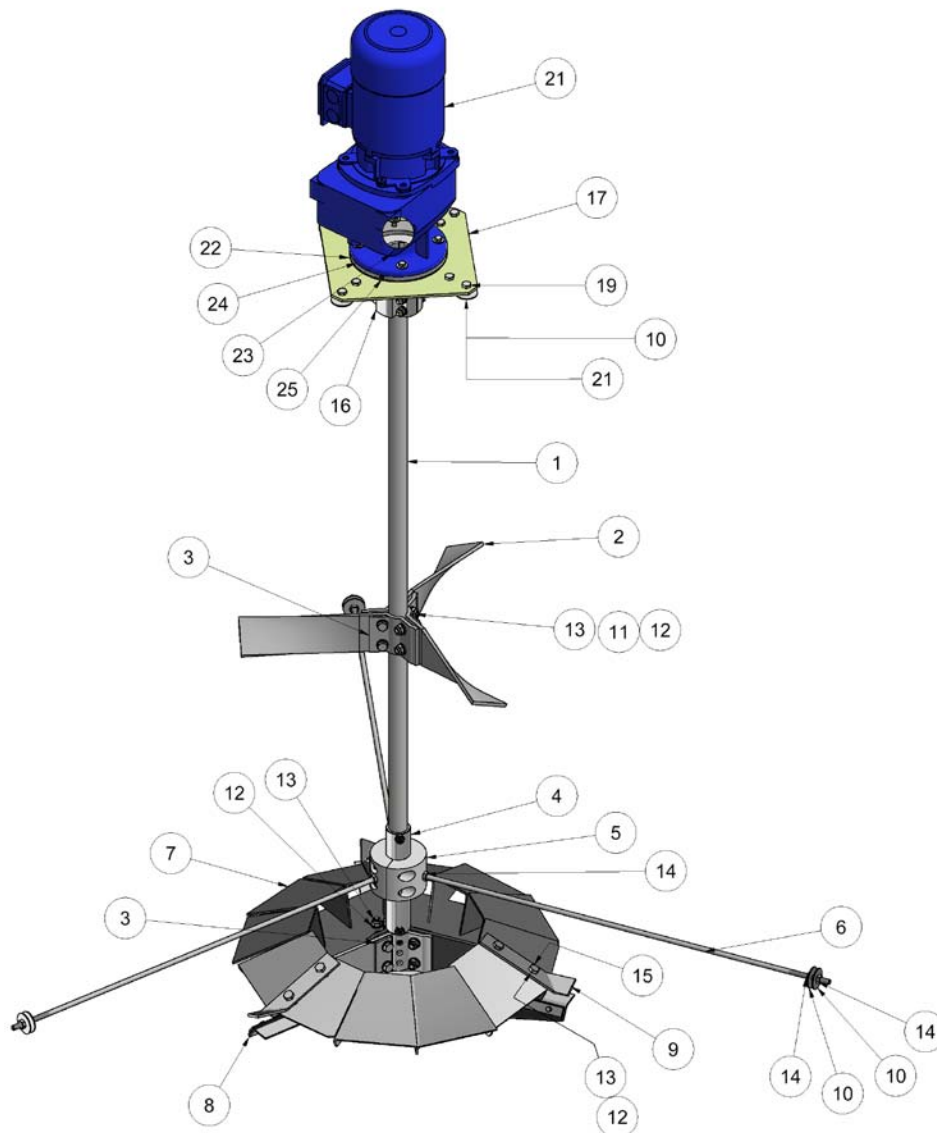

BILL OF MATERIALS - RESIDUAL TANK 6000 L

BILL OF MATERIALS - RESIDUAL TANK 6000 L, WITHOUT STIRRER			
	Item no.	Description	Pcs.
	0340-236	RESIDUAL TANK 6000 L	
1	0140-110	Bottom part for tank vf	1
2	0140-120	Top part for tank vf7	1
3	0140-115	Middle part for tank vf7	2
4	30308035	Set screw m8x35 a2 din 933	135
5	33508013	Nut m8 a2 din 934	153
6	35600058	Nut washer ø8x8,4/24/2 a2 din9021	284
7	0139-710	Bottom agitator vf4-b stainls.	6
8	0139-547	Disc ø45/10.5X2 stainless	22
9	30310030	Set screw m10x30 a2 din 933	22
10	33510017	Nut m10 a2 din 934	22
11	0139-576	Step for mix tank	3
12	0300-216	Ventilation for mixing tanks	1
13	0139-506	Load cells manikin kit vf4	3
14	71200012	Level tilting device/filling	1
15	0139-534	Counter agitator vf4-a	2
16	29100001	Thread tape 1 roll = 10 m	1
17	99900099	Grease for acid protection house, gear LF tank	1
18	74520	Flexible water sealer 300ml	1

	Item no.	Description	Pcs.
19	29900003	Joint band 6mm, sold in rollsof 8 meters	48
20	0140-040	Aco funki logo label 30x30 cm for LF tank	1
21	0140-028	Bracket for sensor	2
22	0140-026	Safety rfid sensor ip69 5 meter cabel	1
23	0140-027	Safety rfid sensor ip69 key	1
24	0139-495	Inspection flange vf4	1
25	0138-451	Membrane dn40	1
26	0139-496	Inspection cover vf4	1
27	0140-140	Outlet pipe for liquid feeding tank vf7	1
28	0140-064	Pvc ball valve 3'/ø90	1
29	0140-063	Pvc pipe ø90 for 3' valve	1
30	30308020	Set screw m8x20 a2 din 933	2
31	33908001	Lock nut m8 a2 din 985	2
32	38504020	Hexagon socket screw m4x20 cha2 din912	4
33	33904000	Lock nut m4 a2	4
34	0140-036	Cover label 45x45 mm for 0140-035, white	6
35	0140-035	Safety label 35x10 cm for liquid feeding tank	2
36	0300-262	Tube for level tilting device/filling	1
37	76200023	Cable tie 290x4,5 mm	2

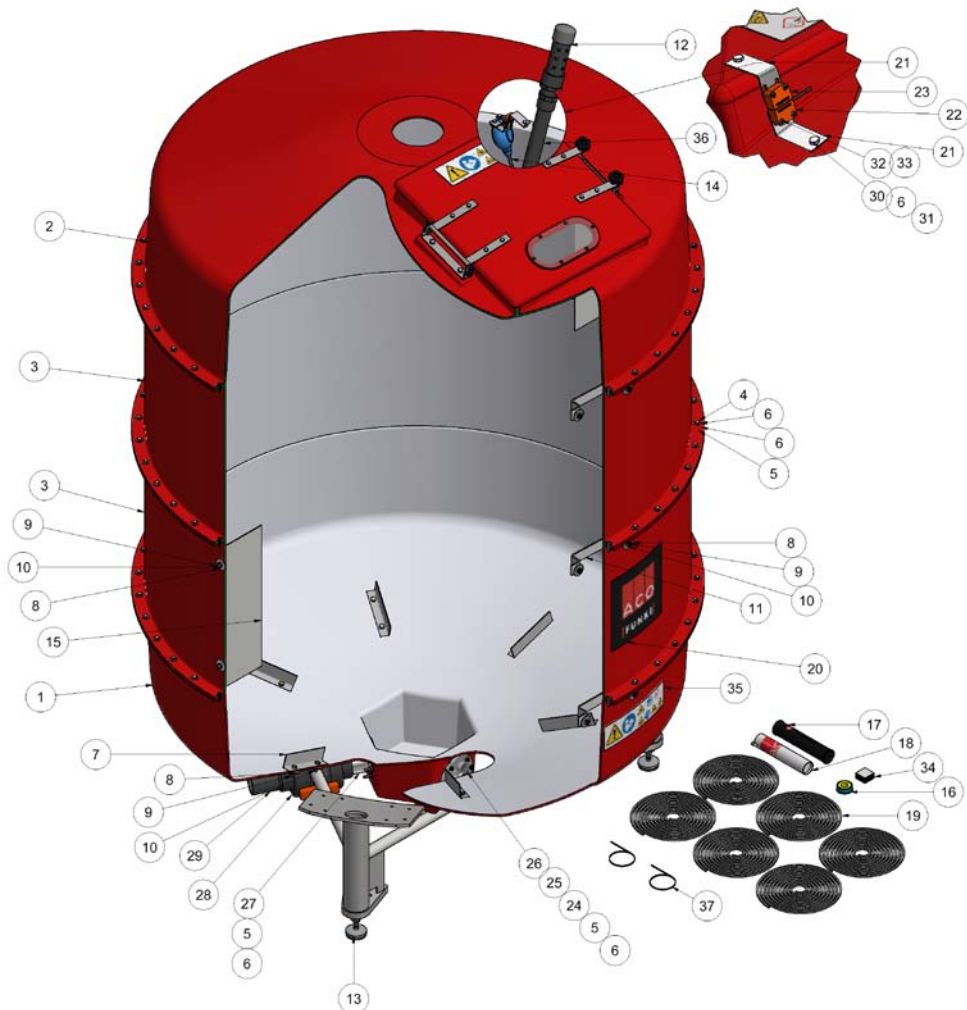

BILL OF MATERIALS - RESIDUAL TANK 6000 L, ONLY STIRRER			
	Item no.	Description	Pcs.
	0340-236	RESIDUAL TANK 6000 L	
1	0139-708	Shaft 6100 vf4-b comp. Stainls	1
2	0139-714	Wing for middel tube	6
3	0139-651	Tension pl.F/bot.Agitat.Stainl	9
4	0330-015	Wearing bushing, long	1
5	0330-020	Split bearing bush	1
6	0139-511	Stay bolt f/bottom bear. Vf4	3
7	0139-716	Bottom agitator 1/3 part vf4-b	3
8	0139-869	Paddle for bottom agitator	3
9	0139-717	Wing blade vf4-b	3
10	0139-547	Disc ø45/10.5X2 stainless	14
11	33900029	Lock nut m10 a2 din 985	14
12	30312045	Set screw m12x45 a2 din 933	18
13	35600080	Flat washer ø12x13/24/2,5 a2 din 125 a	48
14	33912000	Lock nut m12 a2 din 985	24
15	33510017	Nut m10 a2 din 934	9
16	30312030	Set screw m12x30 a2 din 933	6
17	0140-200	Coupling ø30/ø40x118 stainless steel	1
18	0139-999	Tank flange ø200	1
19	35600058	Nut washer ø8x8,4/24/2 a2 din9021	4
20	30310030	Set screw m10x30 a2 din 933	8
21	74038093	Gear motor sk32f 100lp/4 230/400	1
22	0140-169	Lid for grease protection of large gear	1
23	0140-168	Bushing for grease protection of large gear	1
24	0140-167	House for grease for protection of large gear	1
25	9900001	Lubricatingnippel m5 coned type a din 71412	1
26	30308035	Set screw m8x35 a2 din 933	4
27	35600044	Star washer ø8/8,4 a2 din 6798 a	4

